

Pos	Code	Description
1	23495124	AC CORD 3ASL100 240VA 10A SAA
2	13499111	AC CORD H05VV-F 240VE 10A S
3	13499109	AC CORD SJT 117V 10A 3PVC
4	23495125	AC-CORD H05VV 230V 10A S
5	13499209	ADAPTER PLUG (100V)
6	6701409060	ASSY,MEDIA CLAMP L LONG VS-640
7	6701409050	ASSY,MEDIA CLAMP R LONG VS-640
8	1000015117	BASE,CLAMP MEDIA SP-300_01
8	22845112	BASE,MEDIA CLAMP SP-300
9	11849102	BLADE,OLFA AUTO CUTTER XB10
10	1000006571	CABLE-AC,3P 117/230V BR 2.5M
11	23495117	CABLE-AC,VCTF 100V 12A 3P-S
12	22335143	CAP,EPDM
13	1000007260	CARTON,COVER VS-540
14	1000007261	CARTON,SLEEVE VS-540
15	1000006875	CARTON,STAND LEG L/R VS-640
16	1000007262	CARTON,STAND VS-540
17	1000006873	CARTON,TRAY ARM VS-640
18	1000006871	CARTON,TRAY FEEDER VS-640
19	11369115	CASE,PP BOTTLE
20	1000003138	SET,CLEANER STICK TX712A 10PCS.
20	1000007172	CLEANER SET,STICK TX712A 100PCS
20	ST-037	CLEAN STICK TX712A
21	22565682	HEXAGONAL WRENCH 5
22	22535532	LABEL,CARTON CARE #LA762
23	1000007277	LABEL, CARTON VS-540#LA1191
24	1000003017	LABEL,CLAMP MEDIA XC-540#LA991
25	22535144	LABEL,DRAIN BOTTLE #LA29
26	1000001099	LABEL,HARMFUL FIRE #LA915
27	1000006806	LABEL,SET INK S VS-640
28	1000006682	MANUAL,INS JP VS-640
28	1000006683	MANUAL,INS EN VS-640
29	1000006686	MANUAL,REP JP/EN VS-640
30	1000006680	MANUAL,USE JP VS-640
30	1000006681	MANUAL,USE EN VS-640
31	1000006684	MANUAL,USE2 JP VS-640
31	1000006685	MANUAL,USE2 EN VS-640
32	1000002989	PAD,DUMMY CARTRIDGE SP-540V
33	1000006865	PAD,L-LEFT VS-640
34	1000006866	PAD,L-RIGHT VS-640

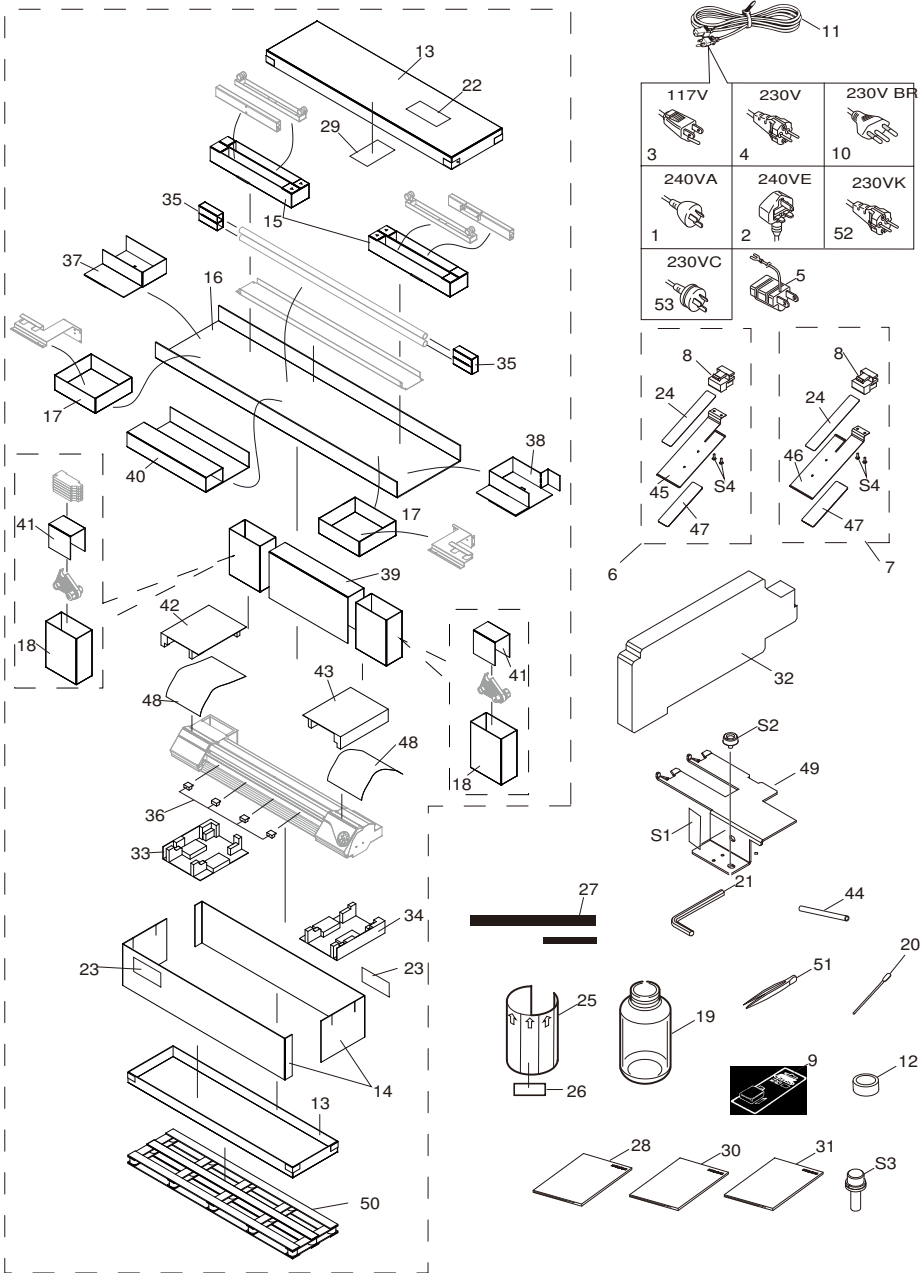

Pos Code	Description
35	1000006874 PAD,PIPE FEEDER SHAFT VS-640
36	21545178 PAD,RAIL SPACER SP-300
37	1000006878 PAD,SPACER STAND L VS-640
38	1000006877 PAD,SPACER STAND R VS-640
39	1000007263 PAD,SUPPORT STAND VS-540
40	1000007264 PAD,TRAY ARM VS-540
41	1000006872 PAD,TRAY FEEDER VS-640
42	1000006863 PAD,U-LEFT VS-640
43	1000006864 PAD,U-RIGHT VS-640
44	22155133 PIPE,TOOL D9*L150 FJ-540
45	22055691 PLATE,LONG CLAMP MEDIA L SP-540V
46	22055693 PLATE,LONG CLAMP MEDIA R SP-540V
47	1000006810 SHEET,CLAMP MEDIA VS-640
47	1000015598 SHEET,CLAMP MEDIA VS-640
48	1000003861 SHEET,MIRROR XJ-740
49	1000006799 STOPPER,CARRIAGE VS-640
50	1000007265 TRAY,SKID VS-540
51	12569656 TWEEZERS PTS-01
52	1000010999 CABLE-AC, H05VV 230V 10A KC
53	13439801 CABLE-AC 3P CHINA 10A250V S
S1	31279201 LABEL,REPACKAGE #LA16
S2	31139103 PLAPOINT,FE4*6 WH
S3	31049157 SCREW,CAP M6*20 3CBC+PW+SW
S4	31229103AS SCREW SET,TRUSS M2*6 NI 100 PCS

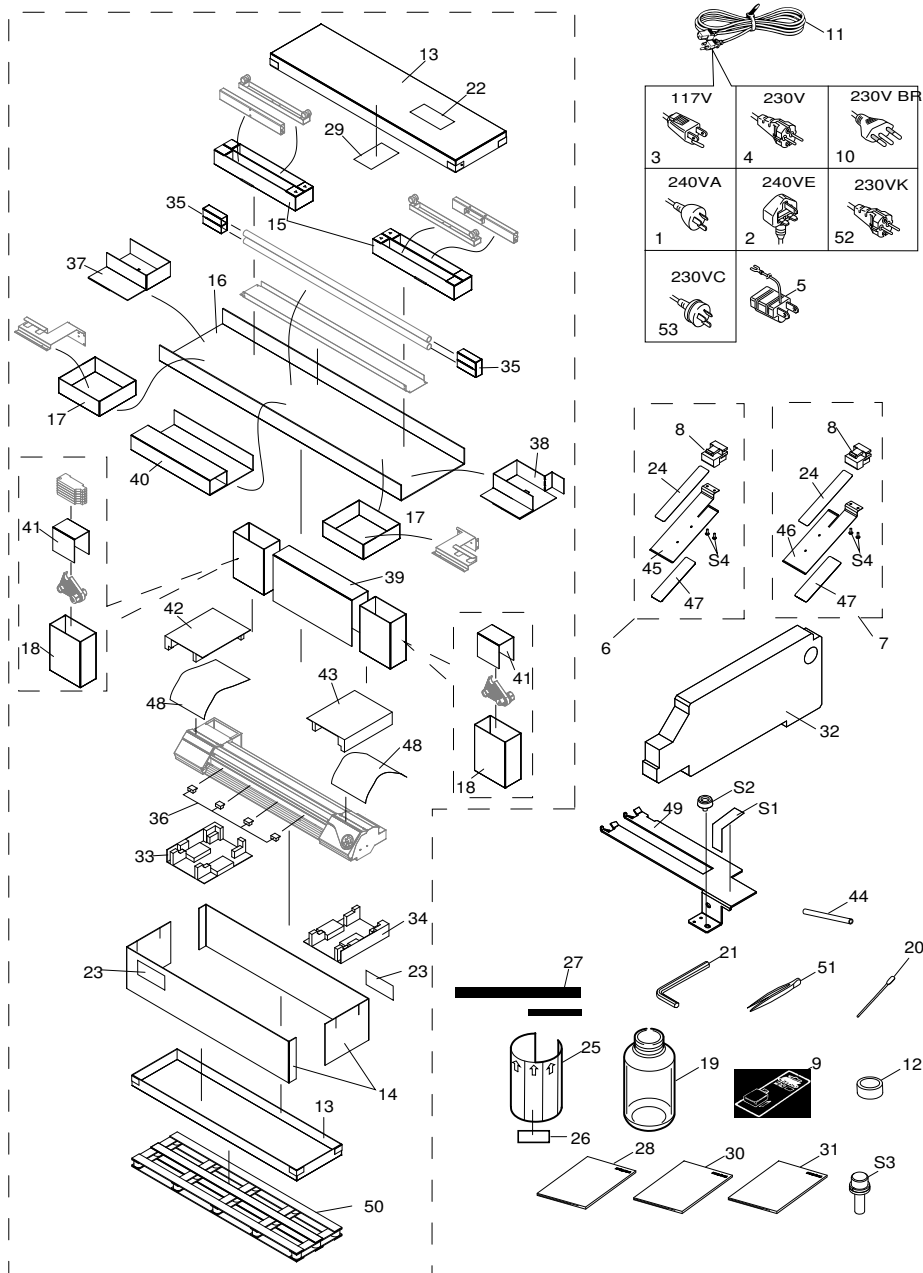

Pos	Code	Description
1	23495124	AC CORD 3ASL100 240VA 10A SAA
2	13499111	AC CORD H05VV-F 240VE 10A S
3	13499109	AC CORD SJT 117V 10A 3PVC
4	23495125	AC-CORD H05VV 230V 10A S
5	13499209	ADAPTER PLUG (100V)
6	6701409060	ASSY,MEDIA CLAMP L LONG VS-640
7	6701409050	ASSY,MEDIA CLAMP R LONG VS-640
8	1000015117	BASE,CLAMP MEDIA SP-300_01
8	22845112	BASE,MEDIA CLAMP SP-300
9	11849102	BLADE,OLFA AUTO CUTTER XB10
10	1000006571	CABLE-AC,3P 117/230V BR 2.5M
11	23495117	CABLE-AC,VCTF 100V 12A 3P-S
12	22335143	CAP,EPDM
13	1000007260	CARTON,COVER VS-540
14	1000008649	CARTON,SLEEVE VS-540_01
15	1000006875	CARTON,STAND LEG L/R VS-640
16	1000007262	CARTON,STAND VS-540
17	1000006873	CARTON,TRAY ARM VS-640
18	1000008647	CARTON,TRAY FEEDER VS-640_01
19	11369115	CASE,PP BOTTLE
20	1000003138	SET,CLEANER STICK TX712A 10PCS.
20	1000007172	CLEANER SET,STICK TX712A 100PCS
20	ST-037	CLEAN STICK TX712A
21	22565682	HEXAGONAL WRENCH 5
22	22535532	LABEL,CARTON CARE #LA762
23	1000007277	LABEL, CARTON VS-540#LA1191
24	1000003017	LABEL,CLAMP MEDIA XC-540#LA991
25	22535144	LABEL,DRAIN BOTTLE #LA29
26	1000001099	LABEL,HARMFUL FIRE #LA915
27	1000006806	LABEL,SET INK S VS-640
27	1000009393	LABEL,SET INK 2 VS-640 #LA1342
28	1000009355	MANUAL,INS JP VS-640_03
28	1000009356	MANUAL,INS EN VS-640_03
29	1000006686	MANUAL,REP JP/EN VS-640
30	1000009353	MANUAL,USE JP VS-640_02
30	1000009354	MANUAL,USE EN VS-640_04
31	1000009357	MANUAL,USE2 JP VS-640_03
31	1000009358	MANUAL,USE2 EN VS-640_03
32	1000008644	PAD,DUMMY CARTRIDGE VS-640
33	1000006865	PAD,L-LEFT VS-640

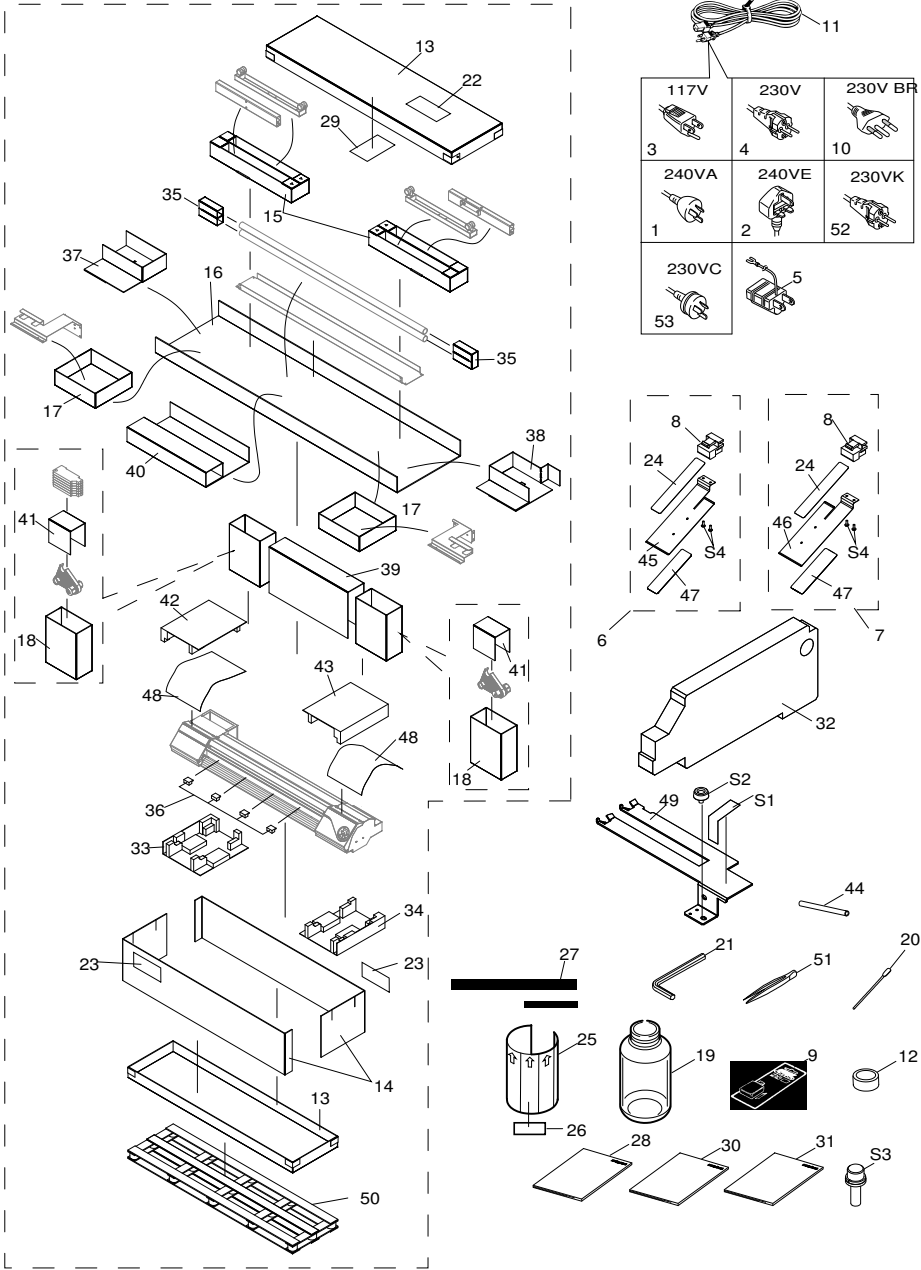

Pos	Code	Description
34	1000006866	PAD,L-RIGHT VS-640
35	1000006874	PAD,PIPE FEEDER SHAFT VS-640
36	21545178	PAD,RAIL SPACER SP-300
37	1000006878	PAD,SPACER STAND L VS-640
38	1000006877	PAD,SPACER STAND R VS-640
39	1000008653	PAD,SUPPORT STAND VS-540_01
40	1000007264	PAD,TRAY ARM VS-540
41	1000006872	PAD,TRAY FEEDER VS-640
42	1000008645	PAD,U-LEFT VS-640_01
43	1000008646	PAD,U-RIGHT VS-640_01
44	22155133	PIPE,TOOL D9*L150 FJ-540
45	22055691	PLATE,LONG CLAMP MEDIA L SP-540V
46	22055693	PLATE,LONG CLAMP MEDIA R SP-540V
47	1000006810	SHEET,CLAMP MEDIA VS-640
47	1000015598	SHEET,CLAMP MEDIA VS-640
48	1000003861	SHEET,MIRROR XJ-740
49	1000008642	STOPPER,CARRIAGE LONG VS-640
50	1000007265	TRAY,SKID VS-540
51	12569656	TWEEZERS PTS-01
52	1000010999	CABLE-AC, H05VV 230V 10A KC
53	13439801	CABLE-AC 3P CHINA 10A250V S
S1	31279201	LABEL,REPACKAGE #LA16
S2	31139103	PLAPOINT,FE4*6 WH
S3	31049157	SCREW,CAP M6*20 3CBC+PW+SW
S4	31229103AS	SCREW SET,TRUSS M2*6 NI 100 PCS

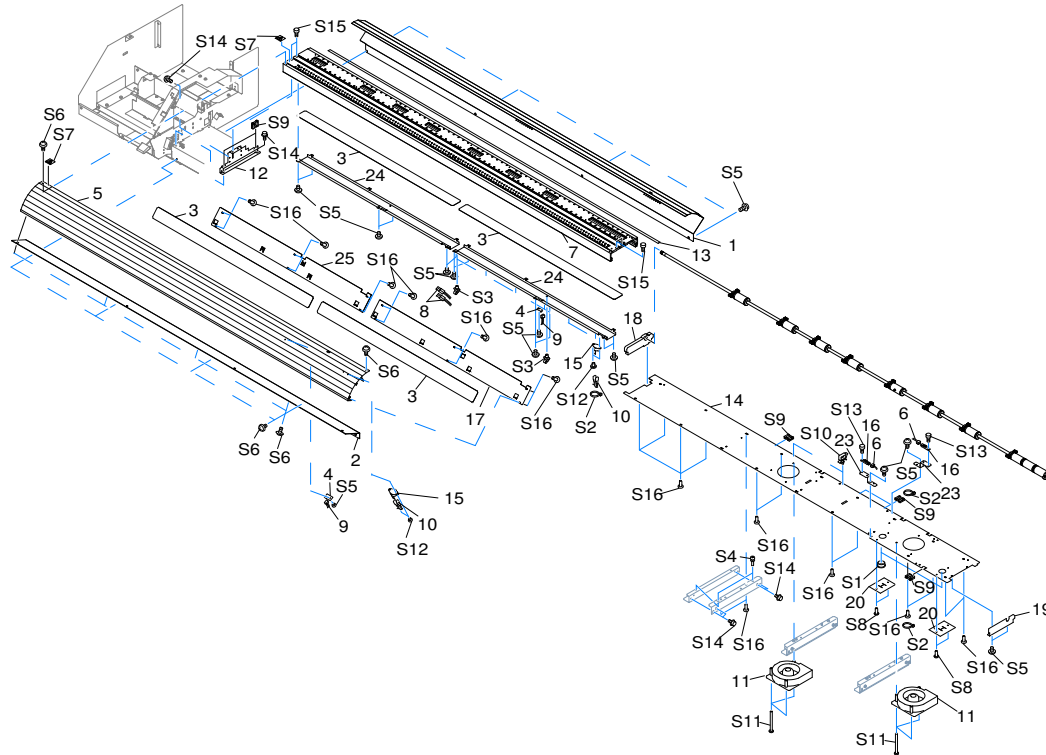

Pos	Code	Description
1	1000004795	APRON,B RS-540
2	1000007199	APRON,F UNDER VS-540
3	1000002165	ASSY,CORD HEATER VP-540
4	6700469060	ASSY,THERMISTOR BOARD SERVICE
4	W701406060	ASSY,THERMISTOR BOARD VS-640
5	1000002148	APRON,F AL VP-540
6	1000002175	CABLE-ASSY,PAPER SENSOR VP-540
7	1000002147	BED,VP-540
8	1000002183	CABLE-ASSY,HEATER VP-540
9	1000002181	CABLE-ASSY,THERMISTOR VP-540
10	1000002184	CABLE-ASSY,THERMOSTAT VP-540
11	1000000764	FAN,A35577-55ROL
12	1000006794	FRAME,SIDE BED L VS-640
13	1000002598	PAD,CUTTER VP-540
14	1000002541	PLATE,SHUTTER VP-540
15	1000013820	SENSOR,03EN 9572 A65
15	15099124	SENSOR,US-602SXTLAS 65OFF 50ON
16	15099115	SENSOR-INTERRUPTER GP2A25NJ
17	1000002606	STAY,DRY HEATER VP-540
17	1000009776	STAY,DRY HEATER VP-540_01
18	1000002600	SHUTTER,BED L VP-540
19	1000002599	SHUTTER,BED R VP-540
20	21625103	SHUTTER,HEATER CORD SP-300
23	1000002585	STAY,PAPER SENSOR VP-540
24	1000002590	STAY,PRINT HEATER VP-540
25	1000009776	STAY,DRY HEATER VP-540_01
S1	31029101	BUSH,NB-19
S2	31329601AS	CLAMP SET,INSULOK T-18S 100 PCS.
S3	31329501AS	CLAMP SET,PUSH MOUNT RT30SSF5 20P
S4	31179106	SCREW,JACK UP SP-540V
S5	31289109AS	CUPSCREW SET,M3*4 NI 100 PCS
S6	31289102AS	CUPSCREW SET,M3*6 NI 50 PCS.
S7	31279106	LABEL,CAUTION HOT SURF NO.778
S8	31299102AS	RIVET SET,NYLON P2655B 20 PCS.
S9	31409702	SADDLE SET,LOCKING WIRE LES-1010 20P
S10	3000000560	SADDLE,LOCKING WIRE LWS-0711Z_TH
S10	31409801AS	SADDLE,LOCKING WIRE LWS-0711Z 20P
S11	31019124	SCREW SET,BINDING M3*35 NI 50 PCS
S12	31019115AS	SCREW SET,BINDING M3*4 3CBC 100 PCS
S13	31049170AS	SCREW SET,CAP M3*8 NI 50 PCS.

Pos	Code	Description
S14	31049169AS	SCREW SET,CAP M4*8 3CBC+PW 20PCS
S15	31049173AS	SCREW SET,CAP M4*10 NI 50 PCS.
S16	31019703	SCREW,BINDING P-TIGHT M3*8 3C 100P

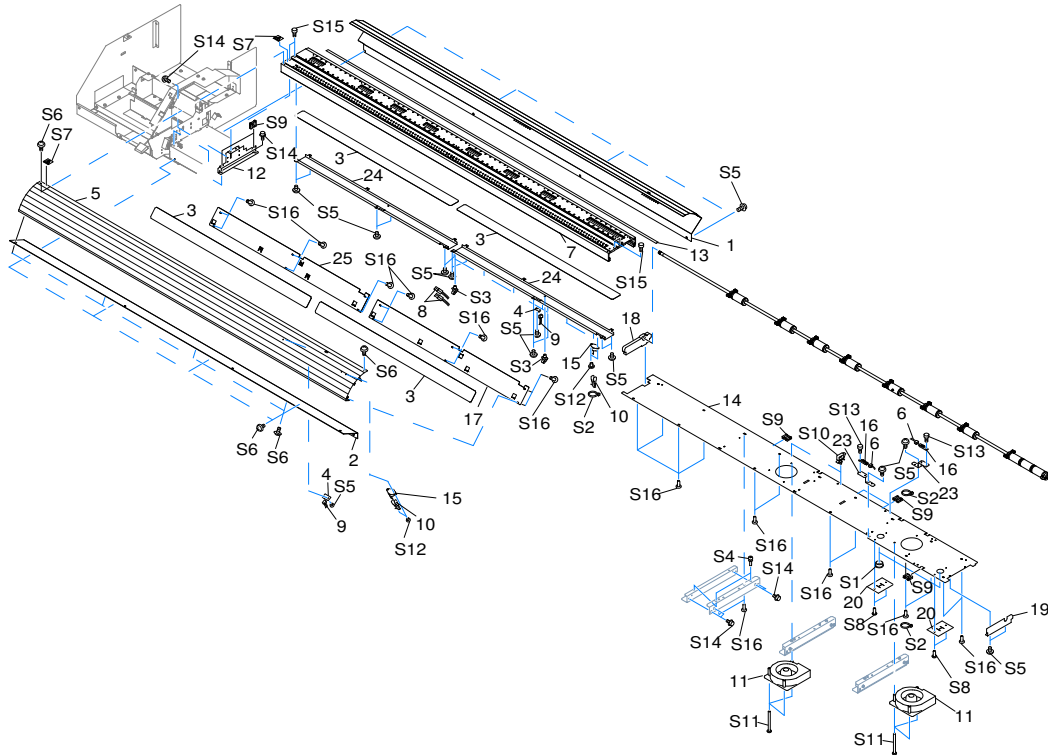

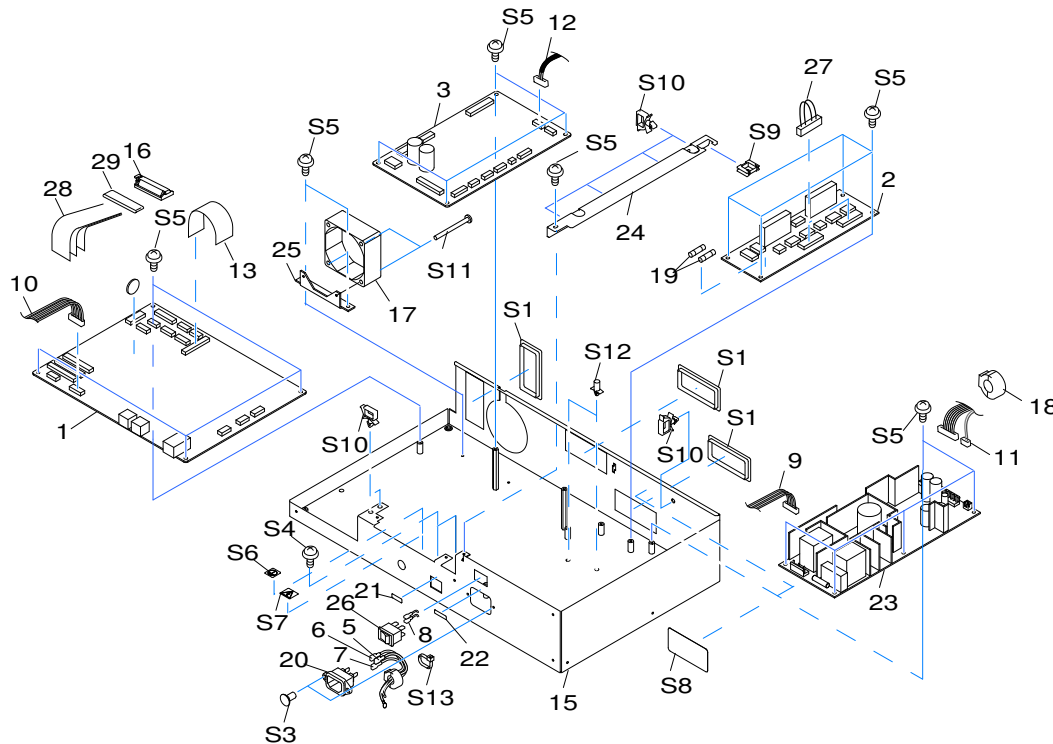

Pos	Code	Description
1	600002233	ASSY,MAIN BOARD LEF-300
1	600004710	ASSY,MAIN BOARD SV LEF2-200
1	600005184	ASSY,MAIN BOARD SV LEF2-300
1	6701039000	ASSY,MAIN BOARD RF-640
1	6701409020	ASSY,MAIN BOARD VS-640
1	6701979010	ASSY,MAIN BOARD RE-640
1	6702419000	ASSY,MAIN BOARD VS-640I
1	6703069000	ASSY,MAIN BOARD RT-640
2	W701406020	ASSY,POWER BOARD VS-640
3	1000006708	ASSY,SERVO BOARD VS-640
3	1000010546	ASSY,SERVO BOARD VS-640I
4	15009101	BATTERY CR2032
5	1000002189	CABLE-ASSY,JUNBI A VP-540
6	1000002190	CABLE-ASSY,JUNBI B VP-540
7	23415268	CABLE-ASSY AC GROUND GREEN SP-540
8	23415116	CABLE-ASSY,JUNBI D SP-300
9	1000002173	CABLE-ASSY,JUNBI E VP-540
10	23415117	CABLE-ASSY,POWER MAIN SP-300
11	1000004961	CABLE-ASSY,POWER SERVO RS-540
12	1000002180	CABLE-ASSY,RELAY JUNCTION VP-540
13	23475197	CABLE CARD 25P1 105L BB FJ-540
15	1000006771	CHASSIS,VS-640
16	11769118	CLAMP,FCM2-S6-14
17	1000006174	FAN,9A0624H414
18	12399353	FILTER(E) TFT-081813N F-540
19	12559105	FUSE,5X20 021706.3MXP 6.3A/250V
20	13429702	INLET AC P01CF01 15A250V
21	1000002682	LABEL,LAN VP-540#LA964
22	22535117	LABEL,POWER CM-500 NO.893
23	1000006130	POWER UNIT,LEB150F-0536-XRLD A
24	1000006772	STAY,CABLE VS-640
25	1000002566	STAY,CHASSIS FAN VP-540
26	13129170	POWER SW AJ7201B
27	1000002043	CABLE-ASSY,230V SELECTOR XC-540
27	1000002044	CABLE-ASSY,117V SELECTOR XC-540
28	23475240	CABLE CARD,36P1 2670L BB HIGH-V
29	1000004149	FILTER(E),FRC-40-12-1.7-013
S1	31029106	BUSH,SQUARE SB-6025
S3	31289105AS	CUPSCREW SET, M3*6 3CBC 100 PCS
S4	31289111AS	CUPSCREW SET, M4*6 NI 100 PCS.

Pos	Code	Description
S5	31289109AS	CUPSCREW SET,M3*4 NI 100 PCS
S6	31279116	LABEL,EARTH MARK-1 NO.E-580
S7	31279121	LABEL,FLASH-LIGHTING NO.E-582
S8	31279191	LABEL,WARNING FUSE REPLACE #347
S9	31409702	SADDLE SET,LOCKING WIRE LES-1010 20P
S10	3000000560	SADDLE,LOCKING WIRE LWS-0711Z_TH
S10	31409801AS	SADDLE,LOCKING WIRE LWS-0711Z 20P
S11	31019124	SCREW SET,BINDING M3*35 NI 50 PCS
S12	31369102	SPACER,PCB SUPPORT PCB-8S
S13	31329601AS	CLAMP SET,INSULOK T-18S 100 PCS.

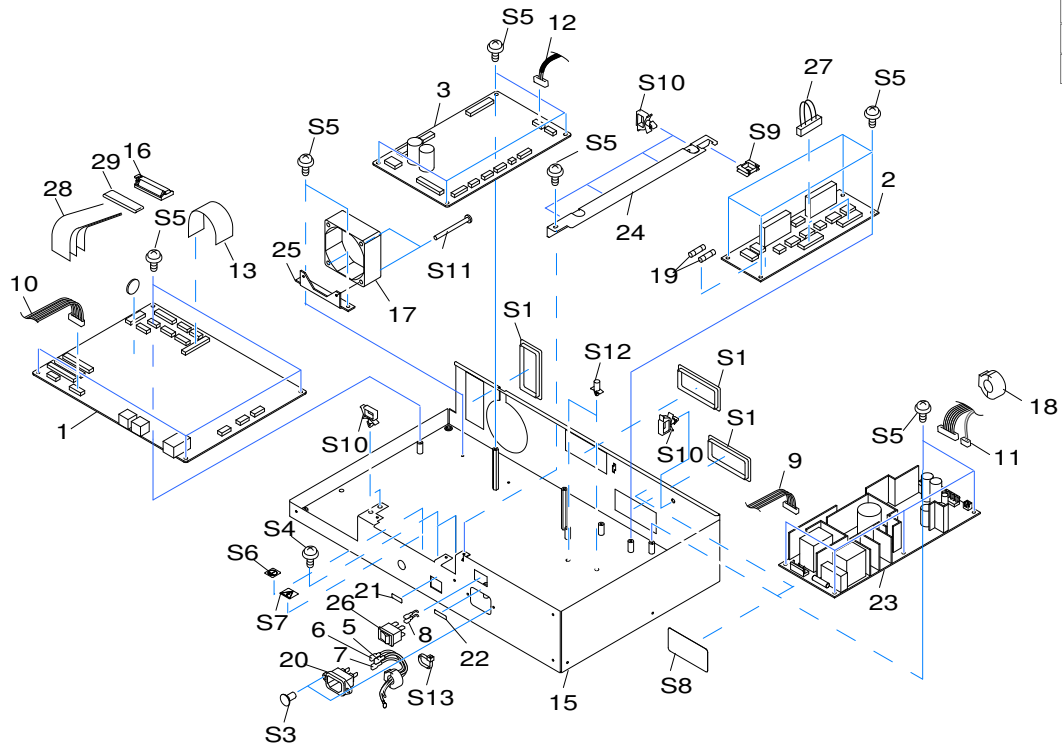

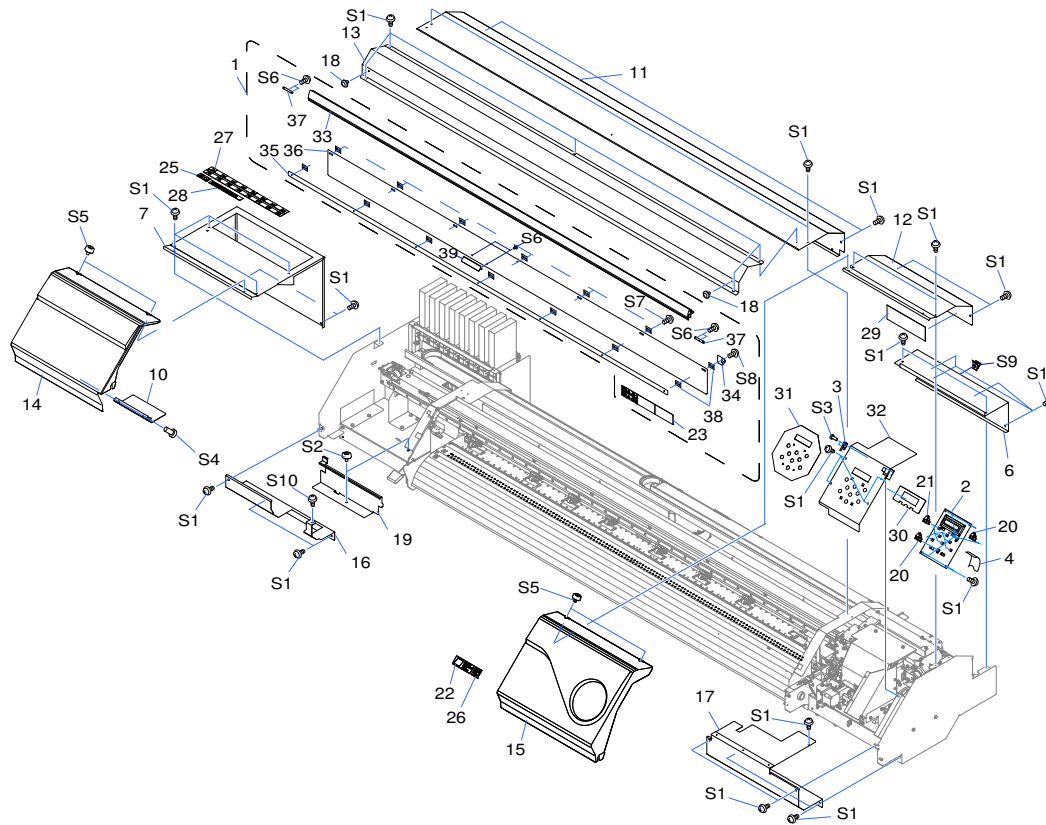

Pos	Code	Description
1	1000006510	ASSY,COVER FRONT VS-640
2	1000007209	ASSY,COVER FRONT VS-540
3	23505834	CABLE-ASSY,MAINT-COVER SW FJ-540
4	23475212	CABLE-CARD,24P1 600L BB
6	1000006795	COVER,CHASSIS VS-640
7	1000006733	COVER,INK CARTRIDGE VS-640
10	1000006793	COVER,MAINTENANCE INKHEAD VS-640
11	1000007207	COVER,RAIL B VS-540
12	1000006791	COVER,RAIL B-RIGHT VS-640
13	1000007208	COVER,RAIL F VS-540
14	1000006509	COVER,SIDE L VS-640
15	1000006508	COVER,SIDE R VS-640
16	1000006792	COVER,UNDER L VS-640
17	1000006756	COVER,UNDER R VS-640
18	12239406	CUSHION,TM-96-6
19	1000006770	FRAME,AUTOCUTTER VS-640
20	1000012564	KEY, TOP CLEAR GS-24
20	22495102	KEY TOP,CLEAR GX-24
21	1000012563	KEY, TOP WHITE GS-24
21	22495101	KEY TOP,WHITE GX-24
22	1000004160	LABEL, REFLECTION XC-540#LA1041
23	1000006358	LABEL,CAUTION LEC-330#LA1149
23	1000019934	LABEL, CAUTION LEC-330 THA#LA3325
24	22535460	LABEL,ENERGY STAR COLOR #LA668
25	1000001099	LABEL,HARMFUL FIRE #LA915
26	1000003489	LABEL,MARK ECO#LA1014
27	1000006804	LABEL,SET INK VS-640
28	1000001620	LABEL,USE ECO-SOL MAX#LA924
29	1000003089	SHEET,FRAME SUPPORT RAIL VP-540
30	1000009436	LCD,CUSHION VS-640
31	1000006803	SHEET,PANEL VS-640
32	1000006790	STAY,PANEL VS-640
33	1000007281	FRAME,COVER F VS-540
34	1000007014	HOOK,INT SW R VS-640
35	1000007283	PLATE,NUT COVER F VS-540
36	1000007282	PLATE,COVER F VS-540
37	1000004198	SHAFT,COVER F VP-540
38	1000020064	WASHER,COVER FJ-50TH
38	21425110	WASHER,COVER FJ-50
39	1000007284	KNOB,COVER FRONT VS-540

Pos	Code	Description
S1	31289109AS	CUPSCREW SET,M3*4 NI 100 PCS
S2	31139103	PLAPOINT,FE4*6 WH
S3	31019149	SCREW SET,BINDING M2.3*8 3CBC 100PCS
S4	31019703	SCREW,BINDING P-TIGHT M3*8 3C 100P
S5	31139104	SCREW,PLAPOINT M4*6 BK FE
S6	31289102AS	CUPSCREW SET,M3*6 NI 50 PCS.
S7	31289112AS	CUPSCREW SET,M3*10 NI 100 PCS.
S8	31049107AS	SCREW SET,CAP M3*12 3CBC 20 PCS
S9	31379111	CLAMP,CABLE CKS-13-H
S10	31289111AS	CUPSCREW SET, M4*6 NI 100 PCS.

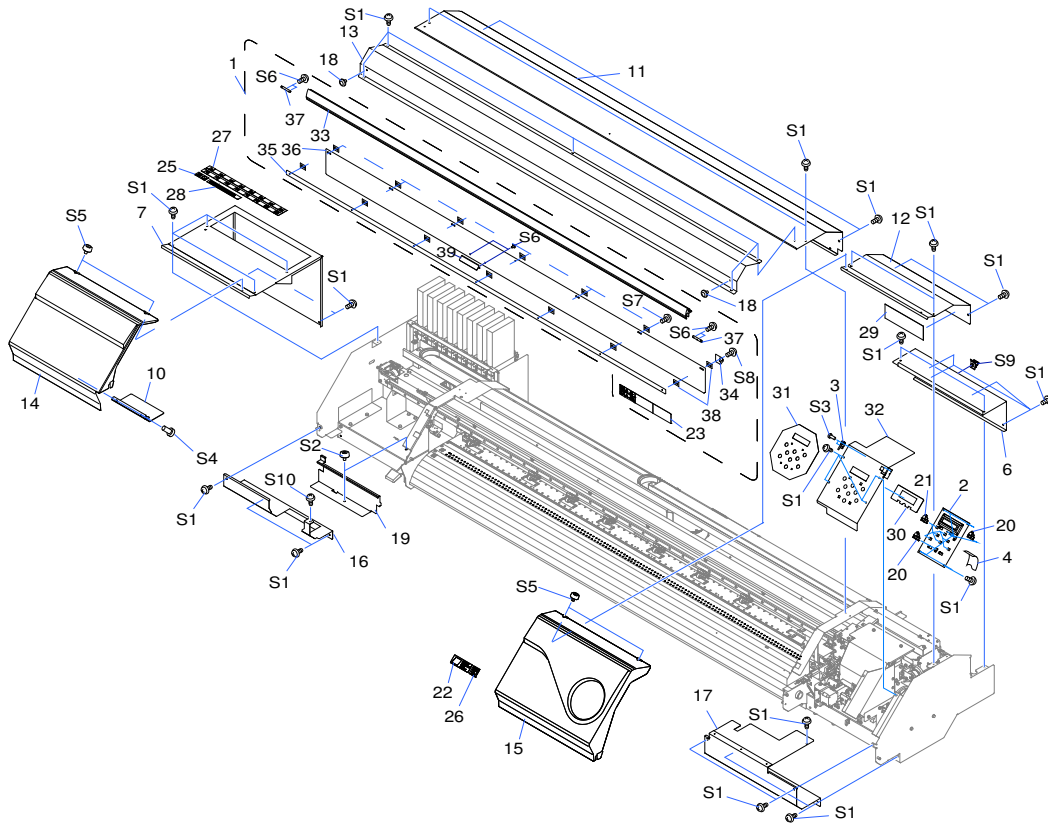

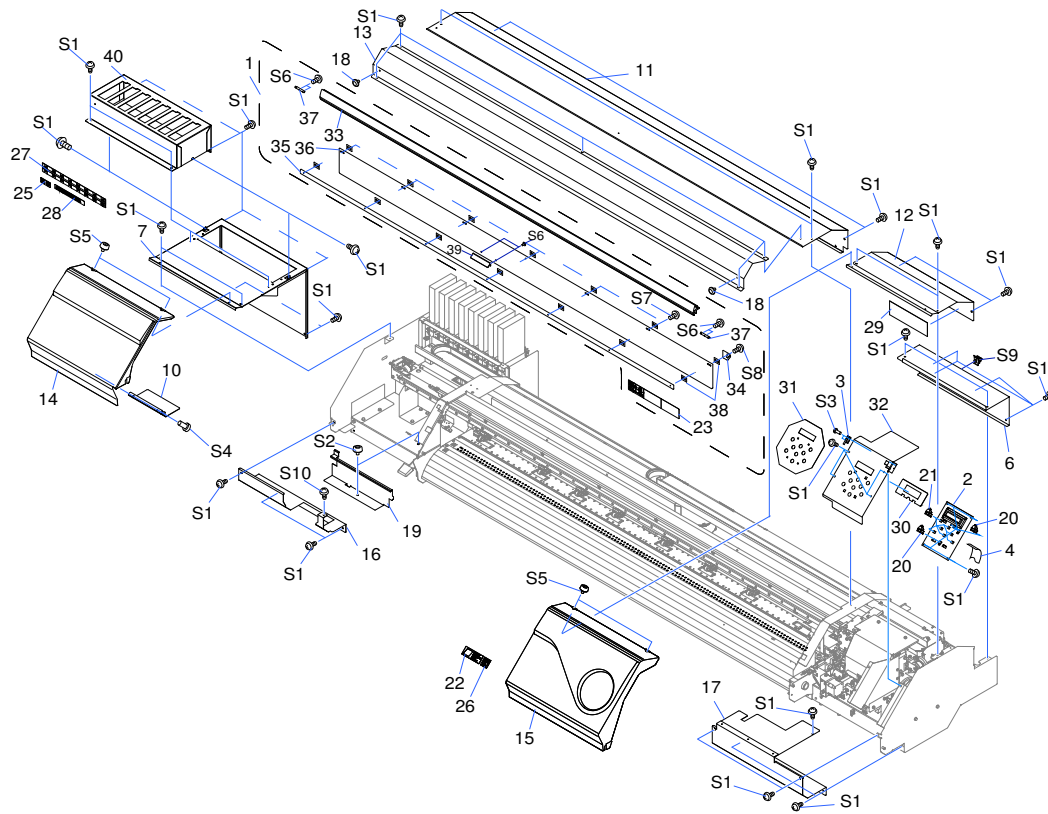

Pos	Code	Description
1	1000007209	ASSY,COVER FRONT VS-540
2	W701406010	ASSY,PANEL BOARD VS-640
2	W702406010	ASSY,PANEL BOARD VS-640I
3	23505834	CABLE-ASSY,MAINT-COVER SW FJ-540
4	23475212	CABLE-CARD,24P1 600L BB
6	1000006795	COVER,CHASSIS VS-640
7	1000008569	COVER,INK CARTRIDGE VS-640_01
10	1000006793	COVER,MAINTENANCE INKHEAD VS-640
11	1000007207	COVER,RAIL B VS-540
12	1000006791	COVER,RAIL B-RIGHT VS-640
13	1000007208	COVER,RAIL F VS-540
14	1000006509	COVER,SIDE L VS-640
15	1000006508	COVER,SIDE R VS-640
16	1000006792	COVER,UNDER L VS-640
17	1000006756	COVER,UNDER R VS-640
18	12239406	CUSHION,TM-96-6
19	1000006770	FRAME,AUTOCUTTER VS-640
20	1000012564	KEY,TOP CLEAR GS-24
20	22495102	KEY TOP,CLEAR GX-24
21	1000012563	KEY,TOP WHITE GS-24
21	22495101	KEY TOP,WHITE GX-24
22	1000004160	LABEL, REFLECTION XC-540#LA1041
23	1000006358	LABEL,CAUTION LEC-330#LA1149
23	1000019934	LABEL, CAUTION LEC-330 THA#LA3325
24	22535460	LABEL,ENERGY STAR COLOR #LA668
25	1000001099	LABEL,HARMFUL FIRE #LA915
26	1000003489	LABEL,MARK ECO#LA1014
27	1000006804	LABEL,SET INK VS-640
28	1000001620	LABEL,USE ECO-SOL MAX#LA924
29	1000003089	SHEET,FRAME SUPPORT RAIL VP-540
30	1000009436	LCD,CUSHION VS-640
31	1000006803	SHEET,PANEL VS-640
32	1000006790	STAY,PANEL VS-640
33	1000007281	FRAME,COVER F VS-540
34	1000007014	HOOK,INT SW R VS-640
35	1000007283	PLATE,NUT COVER F VS-540
36	1000007282	PLATE,COVER F VS-540
37	1000004198	SHAFT,COVER F VP-540
38	1000020064	WASHER,COVER FJ-50TH
38	21425110	WASHER,COVER FJ-50

Pos	Code	Description
39	1000007284	KNOB,COVER FRONT VS-540
40	1000008570	COVER,EXTENDED ICHOLDER UNIT VS-640
S1	31289109AS	CUPSCREW SET,M3*4 NI 100 PCS
S2	31139103	PLAPOINT,FE4*6 WH
S3	31019149	SCREW SET,BINDING M2.3*8 3CBC 100PCS
S4	31019703	SCREW,BINDING P-TIGHT M3*8 3C 100P
S5	31139104	SCREW,PLAPOINT M4*6 BK FE
S6	31289102AS	CUPSCREW SET,M3*6 NI 50 PCS.
S7	31289112AS	CUPSCREW SET,M3*10 NI 100 PCS.
S8	31049107AS	SCREW SET,CAP M3*12 3CBC 20 PCS
S9	31379111	CLAMP,CABLE CKS-13-H
S10	31289111AS	CUPSCREW SET, M4*6 NI 100 PCS.

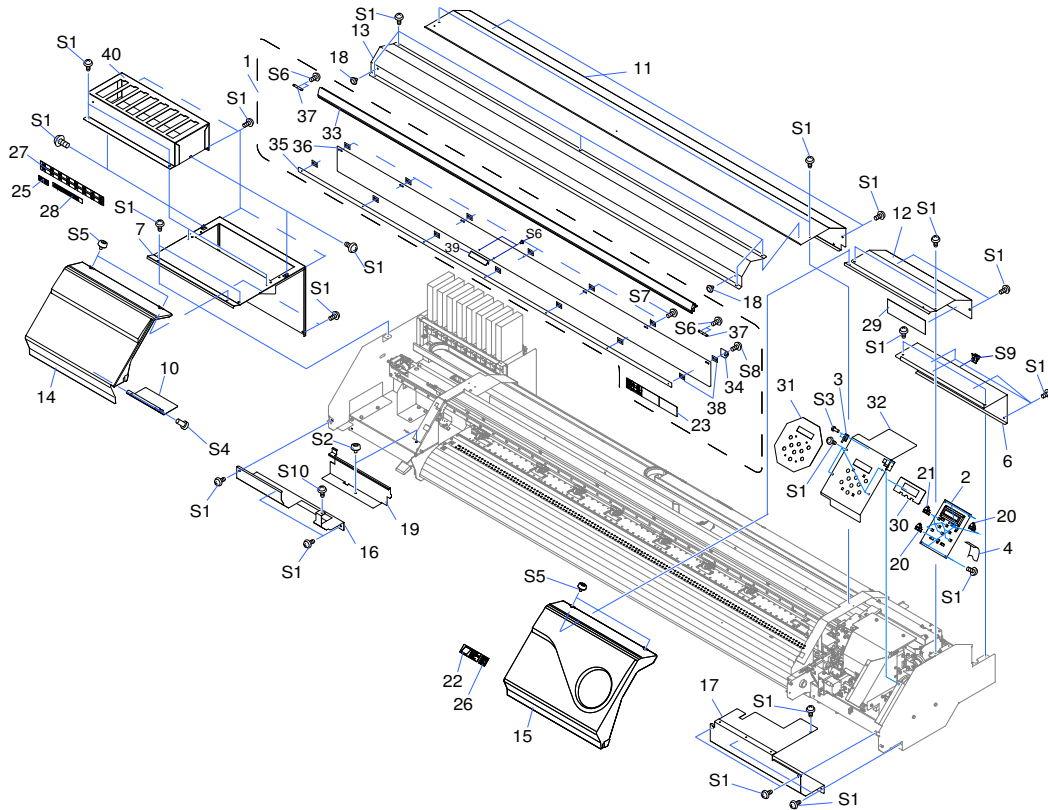

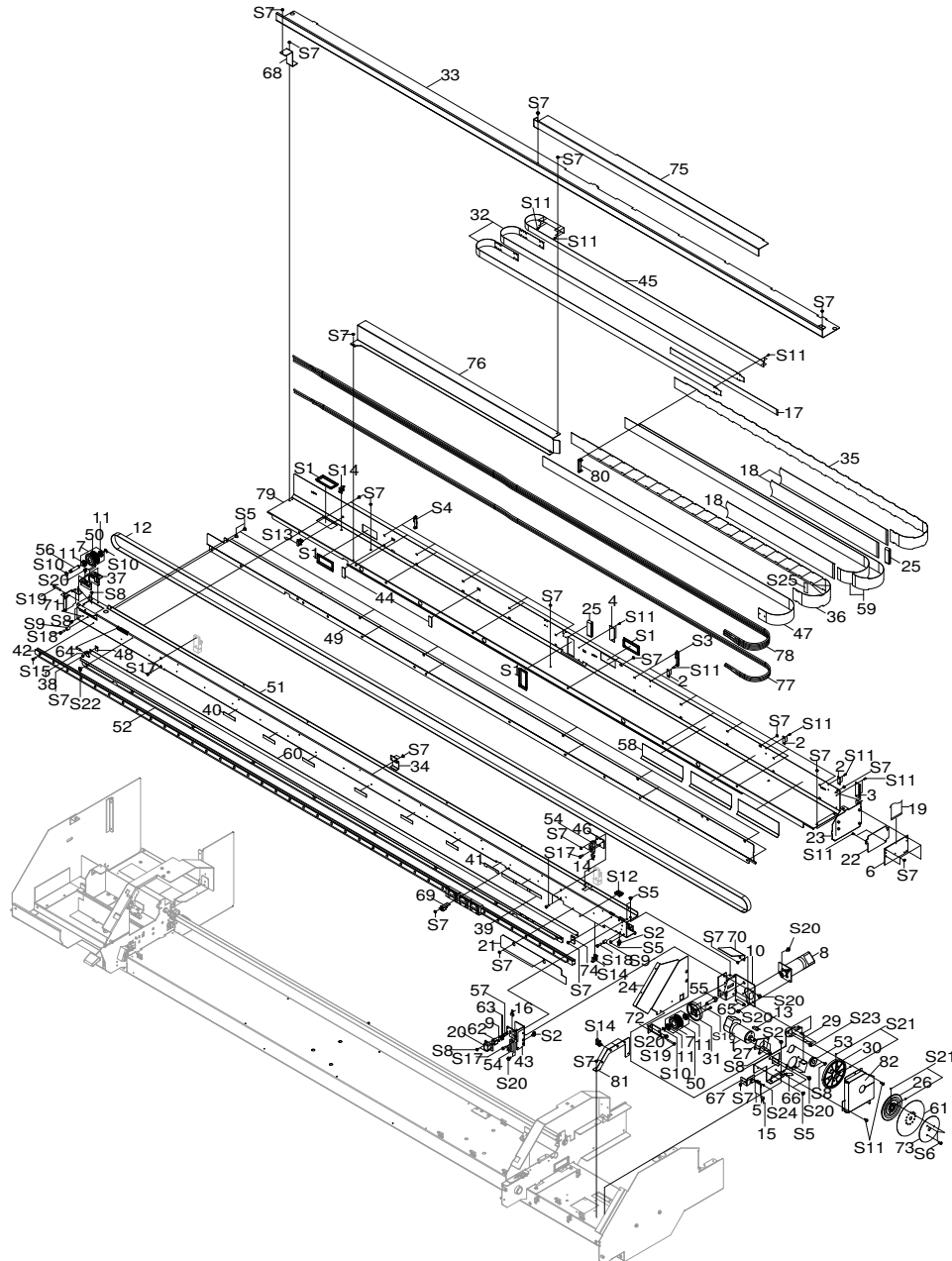

Pos	Code	Description
1	6000002592	ASSY,FEED MOTOR VS-640_01
1	6000003427	ASSY,FEED MOTOR SV VG-640 T
1	6701409040	ASSY,FEED MOTOR VS-640
2	W701406090	ASSY,FLEX 1 VS-640
3	1000018833	COVER,PRINT CABLE FFC VS-640I
3	W7014060A0	ASSY,FLEX 2 VS-640
4	W7014060B0	ASSY,FLEX 3 VS-640
5	W701407040	ASSY,GRIT ENCODER BOARD VS-640
6	W701406080	ASSY,JUNCTION BOARD VS-640
7	6700469030	ASSY,PULLEY VP-540
8	6000002775	ASSY,SCAN MOTOR VS-640_02
8	6701409100	ASSY,SCAN MOTOR VS-640_01
9	11869103	BALL,4MM
10	1000006775	BASE,SCAN DRIVE VS-640
10	1000009095	BASE,SCAN DRIVE VS-640_01
11	22175815	BEARING F8-16ZZ
12	1000002547	BELT,150S2M2153LW-C
13	23415124	CABLE ASSY,GRIT MOTOR SP-300
14	1000006691	CABLE-ASSY,CUT-CAR ORG VS-640
15	1000006694	CABLE-ASSY,GRIT ENC VS-640
16	1000006690	CABLE-ASSY,PRI-CAR ORG VS-640
17	23475238	CABLE-CARD, 15P1 2570L BB
18	23475240	CABLE CARD,36P1 2670L BB HIGH-V
19	1000006704	CABLE-CARD,40P1 400L BB HIGH-V
20	1000016171	CASE,LOCK CJ-70_02
20	21365103	CASE,LOCK CJ-70
21	1000006757	COVER,INNER VS-640
22	1000006801	COVER,JUNCTION BOARD VS-640
22	1000019100	COVER,JUNCTIONBOARD VS-640TH
23	1000006781	COVER,RAIL SIDE VS-640
24	1000006765	COVER,SCAN MOTOR VS-640
25	1000004149	FILTER(E),FRC-40-12-1.7-013
26	1000002593	FLANGE,GRIT-ENCORDER VP-540
27	1000006769	FLANGE,MOTOR FEED VS-640
29	1000006762	FRAME,SCAN MOTOR VS-640
29	1000008039	FRAME,SCAN MOTOR VS-640_01
30	21685128	GEAR H300 S10(B6C16POM)
31	1000001905	GEAR,H187S20(B8)
32	1000002591	GUIDE,CABLE FLEX-CUT VP-540
33	1000007204	GUIDE,CUT CABLE VS-540

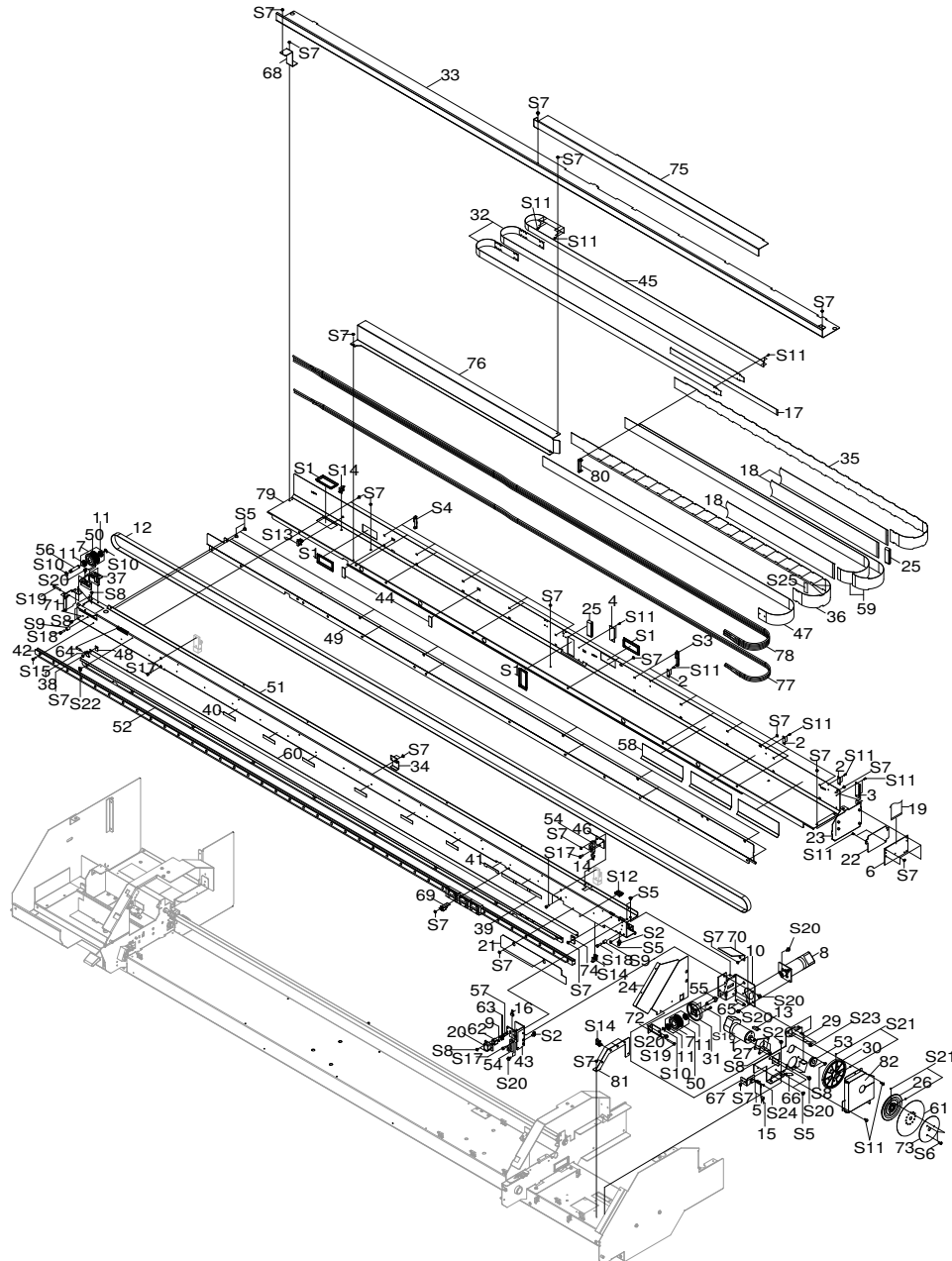

Pos	Code	Description
34	1000009392	HOLDER,BACKUP SHAFTSQUARE RE-640
34	1000015596	HOLDER,BACKUP SHAFTSQUARE RE-640
35	1000005271	HOLDER,CABLE F RS-540
36	1000005174	HOLDER,CABLE RS-540
37	1000001555	HOLDER,IDLE PULLEY XC-540
38	21655131	HOLDER,LINEAR SCALE CJ-70
39	1000002971	LABEL,G-ROLLER 170 VP-540 #LA978
40	1000002970	LABEL,G-ROLLER 50 VP-540 #LA977
41	1000002685	LABEL,PINCH ROLL VP-540#LA968
42	1000002145	L-BEARING,SSR15XW1GGE/W2GE+2050L
43	1000006763	LOCK,STAY VS-640
44	1000003151	PAD,GUIDE TUBE VP-540
45	1000002613	PLATE,CABLE CUT VP-540
46	1000002581	PLATE,CUT ORIGIN VP-540
47	1000002612	PLATE,HOLDER CABLE VP-540
48	22055316	PLATE,LINEAR SCALE CJ-70
49	1000007201	PLATE,RAIL REAR VS-540
50	1000001904	PULLEY,T55P2S16(B21C26)
51	1000007200	RAIL,GUIDE VS-540
52	1000007203	RAIL,LINEAR SCALE VS-540
53	1000006709	R-BEARING,6000ZZNR*NS7S
54	1000006689	SENSOR-INTERRUPTER,EE-SX4009-P1
55	1000001480	SHAFT,DRIVE PULLEY XC-540
56	1000001479	SHAFT,IDLE PULLEY XC-540
57	1000012944	SHAFT,LOCK CJ-70
57	22295117	SHAFT,LOCK CJ-70
58	1000003089	SHEET,FRAME SUPPORT RAIL VP-540
59	1000007205	SHEET,HOLDER CABLE VS-540
60	1000002544	SHEET,LINEAR SCALE VP-540
61	1000002162	SHEET,ROTARY DISK SLIT 360LPI
62	1000016170	SLIDER,LOCK CJ-70_02
62	22185101	SLIDER,LOCK CJ-70
63	22175134	SPRING,A CJ-70
64	22175122	SPRING,BACK UP PNC-960
65	22175157	SPRING,C P-ROLLER CM-500
66	1000000900	SPRING,PINCH 2000 AJ-1000
67	1000002596	STAY,G-ENCODER SENSOR VP-540
68	1000006758	STAY,GUIDE FLEX VS-640
69	22715469	STAY,HOLD SHAFT SQUARE SP-540V
70	1000006774	STAY,OIL GUARD VS-640

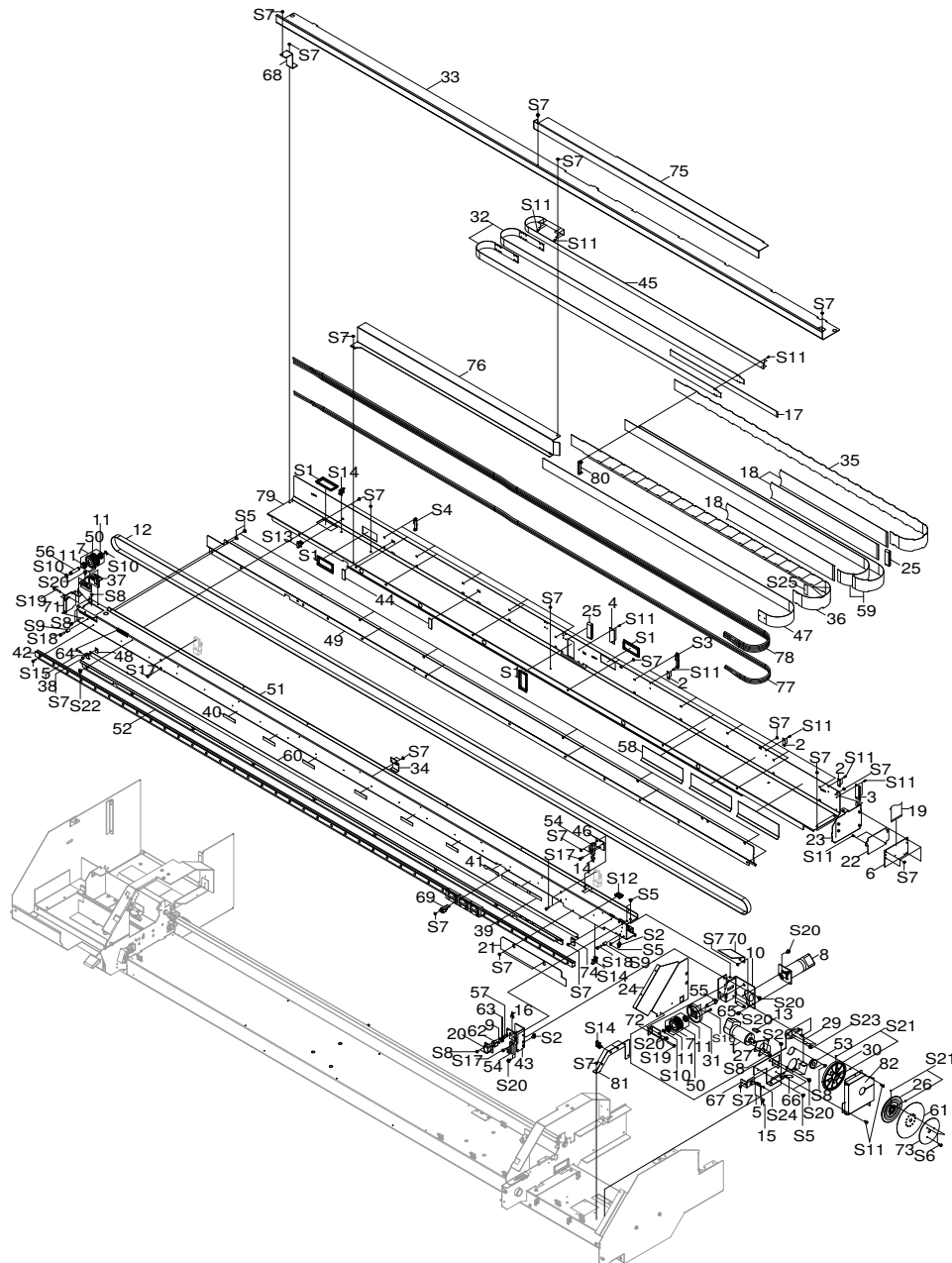

Pos	Code	Description
71	1000002597	STAY,RAILGUIDE L VP-540
72	1000002534	STAY,SHAFT DRIVE PULLEY VP-540
72	1000020056	STAY,SHAFT DRIVE PULLEY VP-540TH
73	1000002594	STOPPER,GRIT-ENCORDER VP-540
73	1000015595	STOPPER,GRIT-ENCORDER VP-540
74	22135441	STOPPER,LINEAR SCALE FJ-540
75	1000003036	SUPPORT,CUT CABLE VP-540
76	1000004142	SUPPORT,GUIDE CABLE TYPE2 VP-540
77	1000007211	TUBE,SJ-RDG3*4 LINK4 VS-540
78	1000007210	TUBE,SJ-RDG3*4 LINK6 VS-540
79	1000007202	FRAME,SUPPORT RAIL VS-540
80	1000006514	GUIDE,TUBE 10 VS-640
81	1000006807	SUPPORT,CABLE VS-640
82	1000008376	COVER,FEED GEAR VS-640
82	1000009413	COVER,FEED GEAR RE-640
S1	31029106	BUSH,SQUARE SB-6025
S2	31329501AS	CLAMP SET,PUSH MOUNT RT30SSF5 20P
S3	3000000033	CLAMP,WIRE PLESS RFC-45VO
S4	3000000030	CLAMP,WIRE PRESS RFC-33V0
S5	31289111AS	CUPSCREW SET, M4*6 NI 100 PCS.
S6	31049170AS	SCREW SET,CAP M3*8 NI 50 PCS.
S6	31289112AS	CUPSCREW SET,M3*10 NI 100 PCS.
S7	31289109AS	CUPSCREW SET,M3*4 NI 100 PCS
S8	31289102AS	CUPSCREW SET,M3*6 NI 50 PCS.
S9	31129102	PIPE SET,POLYCA 4*8*10 20PCS
S10	31149704AS	RING SET,E-RING ETW-6 SUS 100 PCS
S11	31299102AS	RIVET SET,NYLON P2655B 20 PCS.
S12	31409702	SADDLE SET,LOCKING WIRE LES-1010 20P
S13	31409811AS	SADDLE SET,LOCKING WIRE LWS-1211Z 20P
S14	3000000560	SADDLE,LOCKING WIRE LWS-0711Z_TH
S14	31409801AS	SADDLE,LOCKING WIRE LWS-0711Z 20P
S15	31049155AS	SCREW SET,CAP M3*12 BC+PW 20 PCS.
S16	31049171AS	SCREW SET,CAP M3*12 NI 50 PCS.
S17	31049173AS	SCREW SET,CAP M4*10 NI 50 PCS.
S18	31049174AS	SCREW SET,CAP M4*15 NI 20 PCS.
S19	3000000423	CAP-SCREW,4*25 3CBC 100PCS
S19	31049137AS	SCREW SET,CAP M4*25 3CBC 20 PCS
S20	31049169AS	SCREW SET,CAP M4*8 3CBC+PW 20PCS
S21	31199701AS	SCREW SET,SET WP M3*3 NI 20 PCS
S22	31239103AS	SCREW SET,W-SEMS M3*8 NI+PW 50 PCS

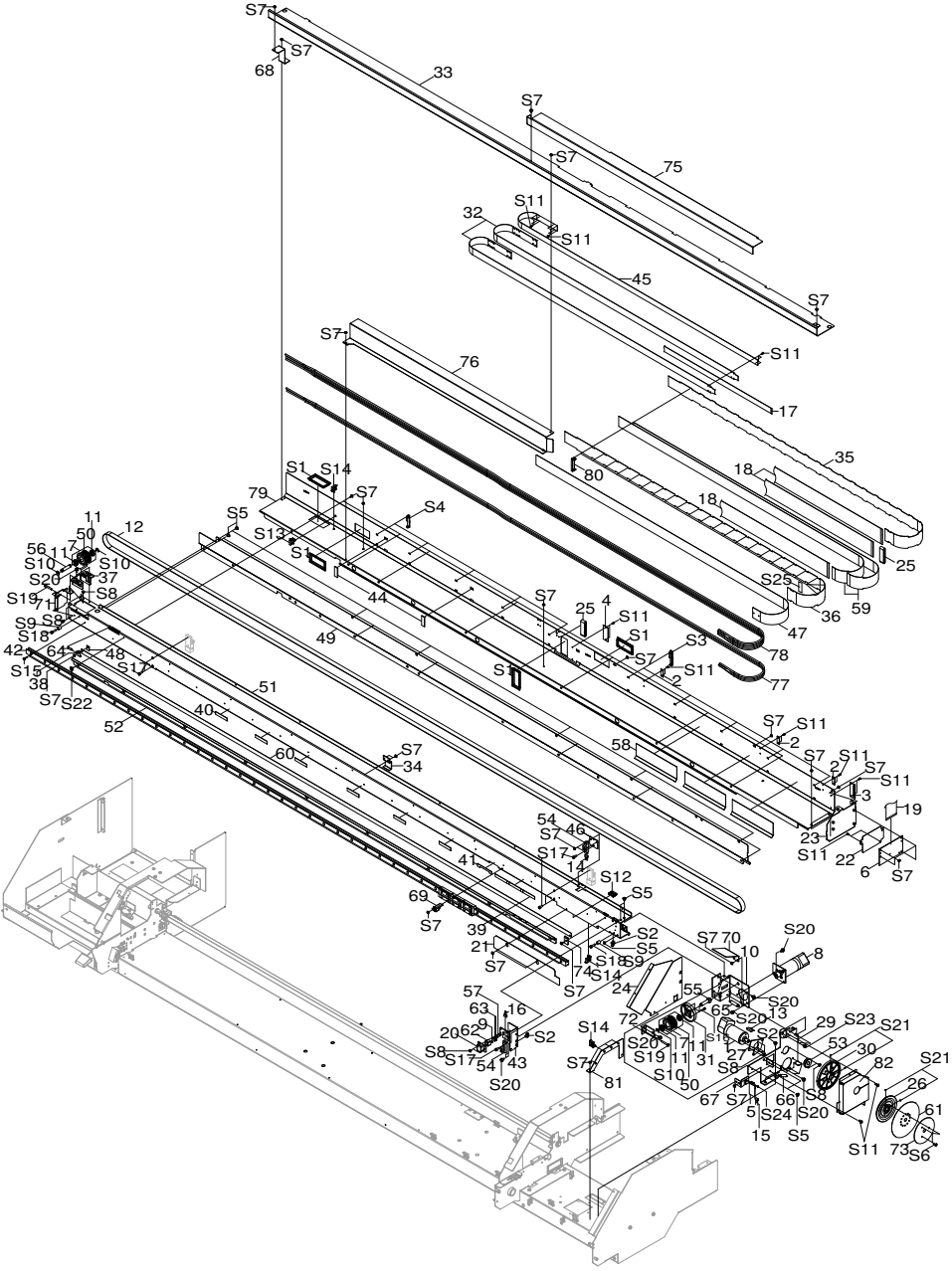

Pos	Code	Description
S23	31069104	SCREW,CAP M4*6+FL NI
S24	31229103AS	SCREW SET,TRUSS M2*6 NI 100 PCS
S25	3000000521	TAPE,FILAMENT 3M #898 12MMX50M
S25	31549101	3M 898 FILAMENT TAPE 12MM*50M

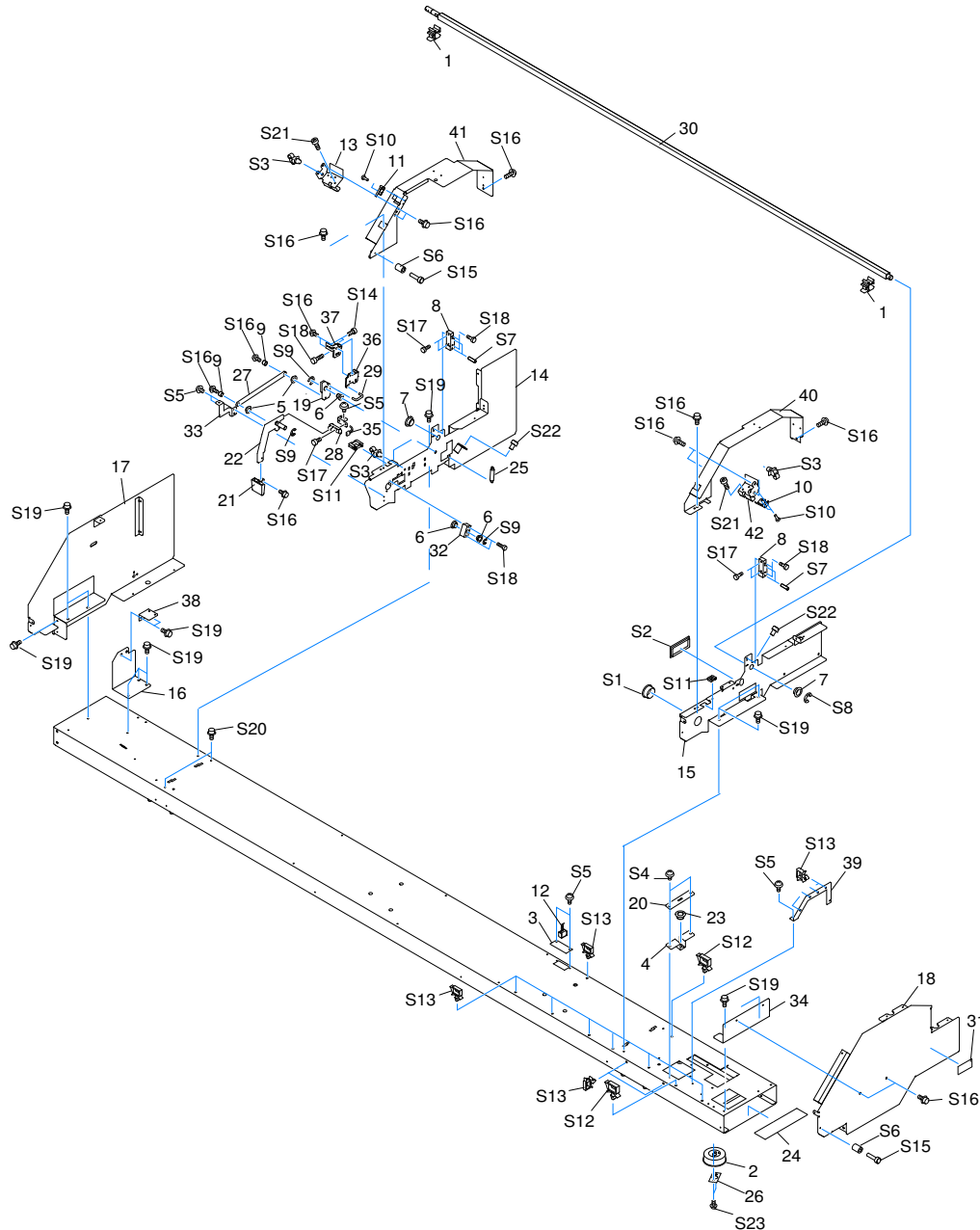

Pos	Code	Description
1	1000015110	ADAPTER,CLAMP MEDIA SP-500_01
1	21905192	ADAPTER,CLAMP MEDIA SP-540V
2	7520501000	ASSY,CAP BOTTLE 2 FJ-52
3	W701406040	ASSY,FAN JUNCTION BOARD VS-640
4	21985140	BRACKET,INK CATCH TANK SP-540V
5	1000018512	BUSH,80F-0603
5	12159573	BUSH,80F-0603
6	1000018503	BUSH,80F-1006
6	12159563	BUSH,80F-1006
7	1000018504	BUSH,SHAFT OILES 80F-1206
7	12159508	BUSH,SHAFT OILES 80F-1206
8	1000002589	BASE,RAIL VP-540
9	1000012953	COLLAR,LEVER FJ-540
9	21745109	COLLAR,LEVER FJ-540
10	1000006696	CABLE-ASSY,F-COVER R VS-640
11	1000006695	CABLE-ASSY,M-COVER L VS-640
12	1000002168	CABLE-ASSY,FAN VP-540
13	1000006785	COVER,INT SW L VS-640
14	1000006728	FRAME,MIDDLE L VS-640
14	1000009381	FRAME,MIDDLE L VS-640_01
15	1000006721	FRAME,MIDDLE R VS-640
16	1000006808	FRAME,RAIL STAY VS-640
17	1000006729	FRAME,SIDE L VS-640
17	1000009382	FRAME,SIDE L VS-640_01
18	1000006768	FRAME,SIDE R VS-640
19	22305101	GUIDE,LEVER SP-300
20	1000006410	HOLDER,PUMP TUBE SP-300I
21	1000001601	KNOB,XC-540
21	1000015118	KNOB,XC-540_01
22	1000006809	LEVER,CAM PINCH VS-640
23	22155763	OILES BUSH 80F-0806
24	1000003088	PAD,BASE BOTTOM VP-540
25	22175105	PINCH ROLL SPRING
26	22055474	PLATE,INK CATCH TANK FJ-52
27	1000002609	PLATE,LEVER LINK VP-540
28	1000006689	SENSOR-INTERRUPTER,EE-SX4009-P1
29	22145393	SHAFT,JOINT PNC-960
30	1000002526	SHAFT,SQUARE VP-540
31	22535444	LABEL,READ MANUAL #LA637
32	22035196	STAND,LEVER SP-300

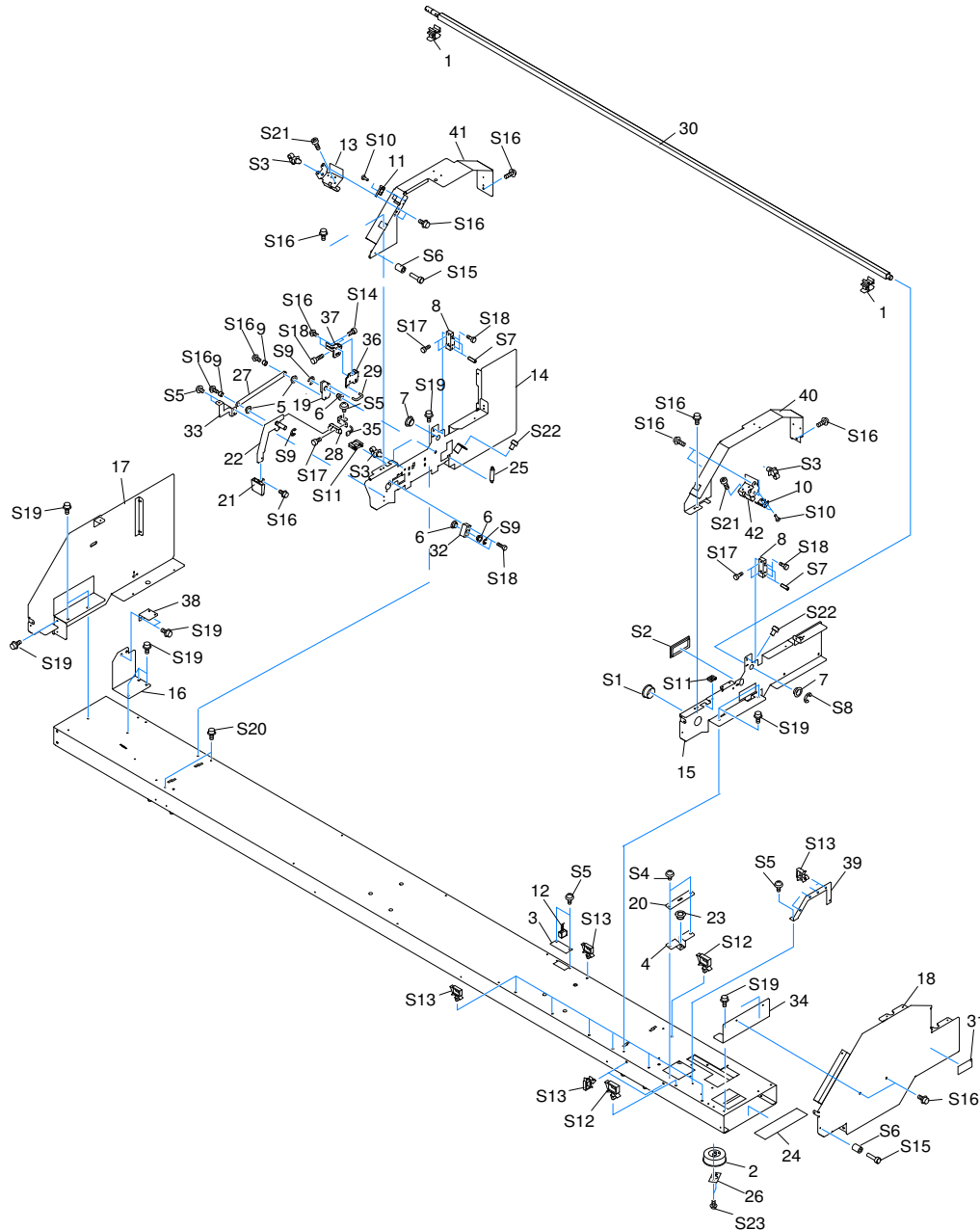

Pos	Code	Description
33	1000002629	STAY,COVER UNDER VP-540
34	1000006788	STAY,FRAME SIDE R VS-640
35	1000002555	STAY,LEVER SENSOR VP-540
36	1000009349	STAY,PINCH LEVER ADJUST RE-640
37	1000009348	STAY,PINCH LEVER RE-640
38	1000002554	STAY,SUPPORT RAIL L VP-540
39	1000006807	SUPPORT,CABLE VS-640
40	1000006783	SUPPORT,FRAME R VS-640
41	1000006784	SUPPORT,FRAME L VS-640
42	1000006786	COVER,INT SW R VS-640
S1	31029101	BUSH,NB-19
S2	31029106	BUSH,SQUARE SB-6025
S3	31329501AS	CLAMP SET,PUSH MOUNT RT30SSF5 20P
S4	31289102AS	CUPSCREW SET,M3*6 NI 50 PCS.
S5	31289109AS	CUPSCREW SET,M3*4 NI 100 PCS
S6	31129101	PIPE SET,POLYCA 3*6*8 20PCS
S7	31119904	PIN,SPRING 2.5*8 SUS STRAIGHT 50 PCS
S8	3000000559	RING,E ETW-10 SUS_TH
S8	31149706AS	RING SET,E-RING ETW-10 SUS 20 PCS
S9	3000000558	RING,E ETW-7 SUS_TH
S9	31149705	RING SET,E-RING ETW-7 SUS 50PCS
S10	31019149	SCREW SET,BINDING M2.3*8 3CBC 100PCS
S11	31409702	SADDLE SET,LOCKING WIRE LES-1010 20P
S12	31409811AS	SADDLE SET,LOCKING WIRE LWS-1211Z 20P
S13	3000000560	SADDLE,LOCKING WIRE LWS-0711Z_TH
S13	31409801AS	SADDLE,LOCKING WIRE LWS-0711Z 20P
S14	31049142AS	SCREW SET,CAP M3*6 NI MEC 20 PCS
S15	31049171AS	SCREW SET,CAP M3*12 NI 50 PCS.
S16	31049169AS	SCREW SET,CAP M4*8 3CBC+PW 20PCS
S17	31049173AS	SCREW SET,CAP M4*10 NI 50 PCS.
S18	3000000423	CAP-SCREW,4*25 3CBC 100PCS
S18	31049137AS	SCREW SET,CAP M4*25 3CBC 20 PCS
S19	31069104	SCREW,CAP M4*6+FL NI
S20	31179106	SCREW,JACK UP SP-540V
S21	31049170AS	SCREW SET,CAP M3*8 NI 50 PCS.
S22	31799107	SCREW SET,CAP M4*6 NI 20PCS
S23	31239125AS	SCREW SET,W-SEMS M3*8 SUS 50 PCS.

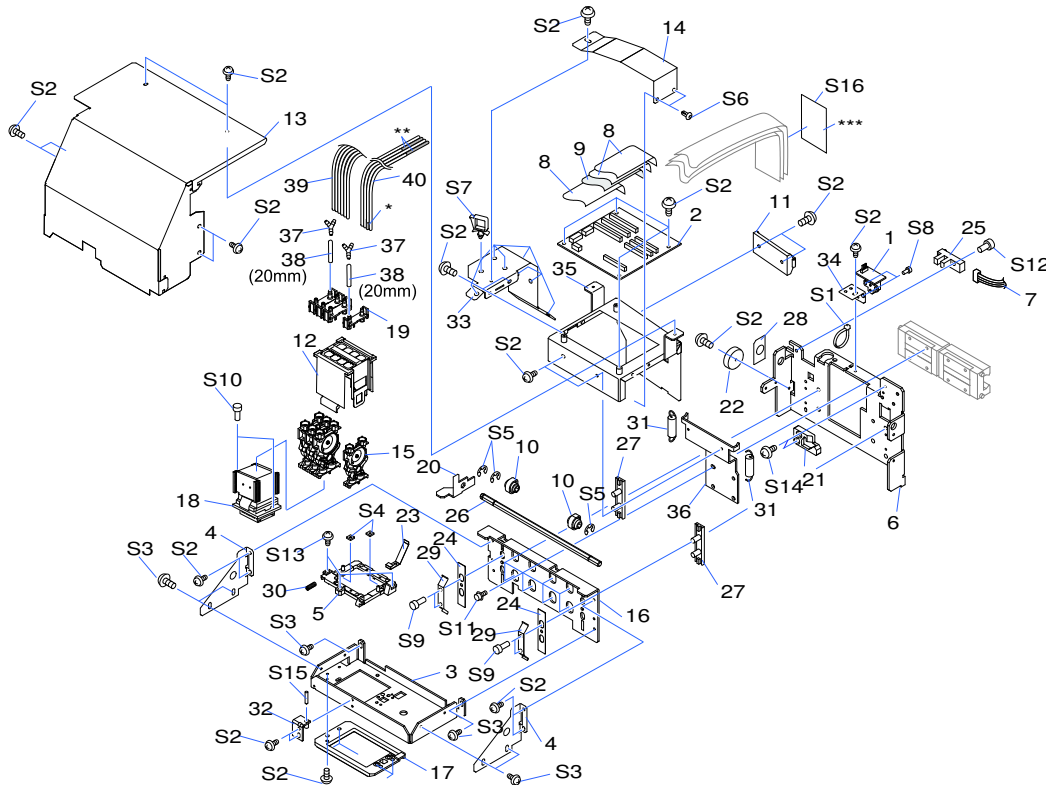

Pos	Code	Description
1	6700989040	ASSY,LINEAR ENC BOARD SERVICE 1
1	W701407030	ASSY,LINEAR ENCODER BOARD VS-640
2	W701407011	ASSY,PRINT CARRIAGE VS-640_01
3	1000006716	BASE,CARRIAGE AL VS-640
4	1000006717	BASE,CARRIAGE SIDE AL VS-640
5	1000006530	BASE,HEAD VS-640
6	1000006752	BASE,HOLDER CARRIAGE VS-640
7	1000006692	CABLE-ASSY,HEAD UD SENS VS-640
8	1000006702	CABLE-CARD,29P1 256L BB HIGH-V
9	1000006703	CABLE-CARD,29P1 276L BBR HIGH-V
10	1000015115	CAM,CARRIAGE FJ-540_02
10	21775103	CAM,CARRIAGE FJ-540
11	11769118	CLAMP,FCM2-S6-14
12	1000006528	COVER,HEAD INKJET VS-640
13	1000009151	COVER,PRINT CARRIAGE VS-640_01
13	1000013798	COVER,PRINT CARRIAGE VS-640_02
14	1000006805	COVER,PRINT JUNCTION VS-640
15	1000006526	DAMPER,INK VS-640
15	1000013784	DAMPER,INK IHP XR-640
15	1000016472	DAMPER,INK IHP2 XR-640
16	1000006718	FRAME,CARRIAGE U/D VS-640
17	1000006525	GUIDE,CARRIAGE CAP VS-640
17	1000012825	GUIDE,CARRIAGE CAP VS-640_01
18	6701409010	ASSY,HEAD INKJET VS-640
19	1000006529	JOINT,HEAD VS-640
20	1000002587	LEVER,CARRIAGE VP-540
20	1000016620	LEVER,CARRIAGE VP-540_02
21	21345105	LOCK,CJ-500
22	1000006847	MAGNET,VS-640
22	1000010491	MAGNET,SMF-2137
23	1000006531	PLATE,GND VS-640
24	22055548	PLATE,SLIDER CARRIAGE FJ-540
25	1000006689	SENSOR-INTERRUPTER,EE-SX4009-P1
26	1000006766	SHAFT,HEXAGON CARRIAGE VS-640
27	1000015113	SLIDER,CARRIAGE FJ-540_02
27	22185127	SLIDER,CARRIAGE FJ-540
28	1000002623	SPACER,U/D LEVER VP-540
29	22175159	SPRING,CARRIAGE SIDE FJ-50
30	22175520	SPRING,HEAD ADJUST 500 FJ-540
31	22625109	SPRING,PULL CARRIAGE 3500 FJ-540

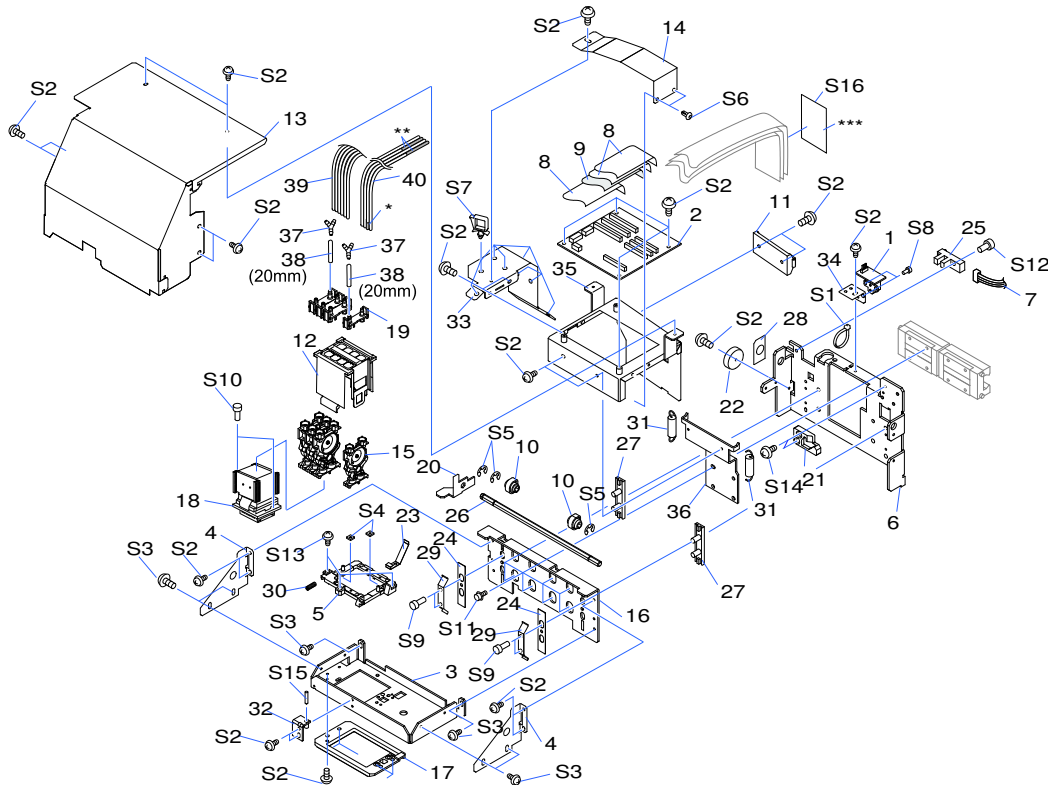

Pos	Code	Description
32	1000006732	STAY,ALIGN HEAD VS-640
33	1000006722	STAY,CARRIAGE TUBE VS-640
33	1000009890	STAY,CARRIAGE TUBE VS-640_01
34	1000000417	STAY,ENCORDER SENSOR SP-540V
35	1000006764	STAY,HOLDER CARRIAGE BOARD VS-640
36	1000006761	SUPPORT,CARRIAGE BOARD VS-640
37	1000002679	ADAPTER,JUNCTION VPY306
38	1000007020	ASSY,TUBING 3*200MM VS-640
39	1000007210	TUBE,SJ-RDG3*4 LINK6 VS-540
39	1000009883	TUBE,SJ-RDG3*4 LINK6 VS-540_01
40	1000007211	TUBE,SJ-RDG3*4 LINK4 VS-540
40	1000009887	TUBE,SJ-RDG3*4 LINK4 VS-540_01
S1	31329601AS	CLAMP SET,INSULOK T-18S 100 PCS.
S2	31289109AS	CUPSCREW SET,M3*4 NI 100 PCS
S3	31289102AS	CUPSCREW SET,M3*6 NI 50 PCS.
S4	31109601	NUT SET,SQUARE M3*6*1.6 FE NI 100PCS
S5	31149703AS	RING SET,E-RING ETW-4 100 PCS.
S6	31299102AS	RIVET SET,NYLON P2655B 20 PCS.
S7	31409811AS	SADDLE SET,LOCKING WIRE LWS-1211Z 20P
S8	31019148AS	SCREW SET,BINDING M2.6*4 NI 100 PCS
S9	31799103	SCREW SET,CAP M3*15 NI 20PCS
S10	31049170AS	SCREW SET,CAP M3*8 NI 50 PCS.
S11	31049169AS	SCREW SET,CAP M4*8 3CBC+PW 20PCS
S12	31049173AS	SCREW SET,CAP M4*10 NI 50 PCS.
S13	31089121AS	SCREW SET,PAN M2.3*8 NI+PW 100PCS
S14	31239125AS	SCREW SET,W-SEMS M3*8 SUS 50 PCS.
S15	31199905AS	SCRW SET,SET CONE M3*16 NI 20 PCS
S16	39008183	DUNPLON TAPE NO.375 75MM*50M

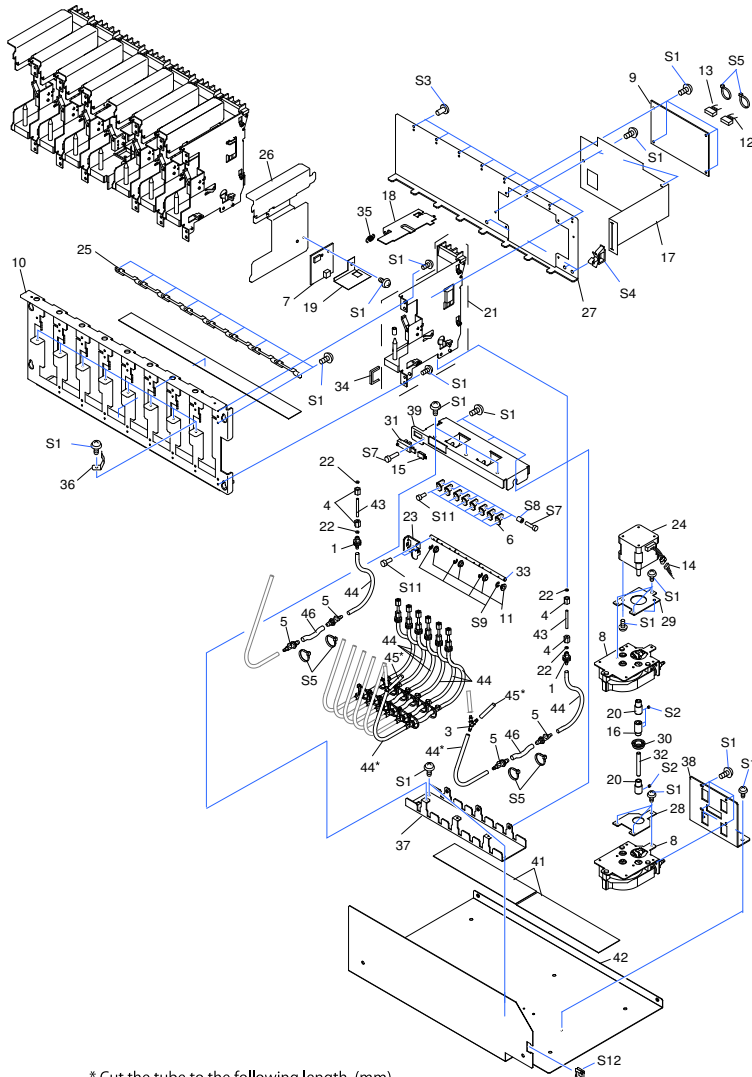

* Cut the tube to the following length. (mm)

Cartridge	Between No.1 Adapter(Ink Cartridge) and Choke No.44	Between Choke and No.2 Adapter No.44*	Between No.3 Y Adapter and Circulate Pump No.45*
1	90		
2	90		
3	105		
4	105		
5	140		
6	140		
7	180	80	250
8	180	80	250

Pos	Code	Description
1	1000004796	ADAPTER,JOINT 2-3FAI RS-540
3	1000002679	ADAPTER,JUNCTION VPY306
4	11909133	ADAPTER,SCREW 2FAI FJ-50
5	1000006327	ADAPTER,TUBE 3-4 LEC-330
5	1000015119	ADAPTER,TUBE 3-4 LEC-330_01
6	1000006909	ARM,TUBE VALVE VS-640
7	W701406070	ASSY,CARTRIDGE IC BOARD VS-640
8	6701219010	ASSY,CIRCULATING PUMP LEC-330
9	W701406030	ASSY,INK TANK BOARD VS-640
10	1000006727	BASE,INK CARTRIDGE VS-640
11	1000018512	BUSH,80F-0603
11	12159573	BUSH,80F-0603
12	1000006698	CABLE-ASSY,INK IC 1-4 VS-640
13	1000006699	CABLE-ASSY,INK IC 5-8 VS-640
14	1000006700	CABLE-ASSY,MIX PUMP VS-640
15	1000006907	CABLE-ASSY,VALVE SENS VS-640
16	1000002564	COUPLING,PUMP VP-540
17	1000006742	COVER,BOARD I/C VS-640
18	12029300	COVER,HOLDER I/C FJ-50
19	1000006743	COVER,SENSOR I/C VS-640
19	1000007298	COVER,SENSOR I/C VS-640_01
20	1000012988	GEAR,S10B20
20	21685122	GEAR,S10S20
21	6700980300	ASSY,HOLDER I/C RS-540
22	11659149	HOLDER,RING O 2FAI FJ-50
23	1000006911	LEVER,TUBE VALVE VS-640
24	1000018516	MOTOR,103-593-1041
24	22435106	MOTOR,103-593-1041
25	1000006740	PLATE,BASE INK CARTRIDGE VS-640
26	1000006744	PLATE,HOLDER I/C VS-640
27	1000006741	PLATE,INK JOINT2 VS-640
28	1000002595	PLATE,P-BEARING VP-540
29	1000001585	PLATE,P-MOTOR XC-540
29	1000020054	PLATE,P-MOTOR XC-540TH
30	22175815	BEARING F8-16ZZ
31	1000006689	SENSOR-INTERRUPTER,EE-SX4009-P1
32	1000002563	SHAFT,PUMP VP-540
33	1000006910	SHAFT,TUBE VALVE VS-640
34	1000006901	SPACER,INK CARTRIDGE VS-640
35	22175167	SPRING,CARTRIDGE FJ-50

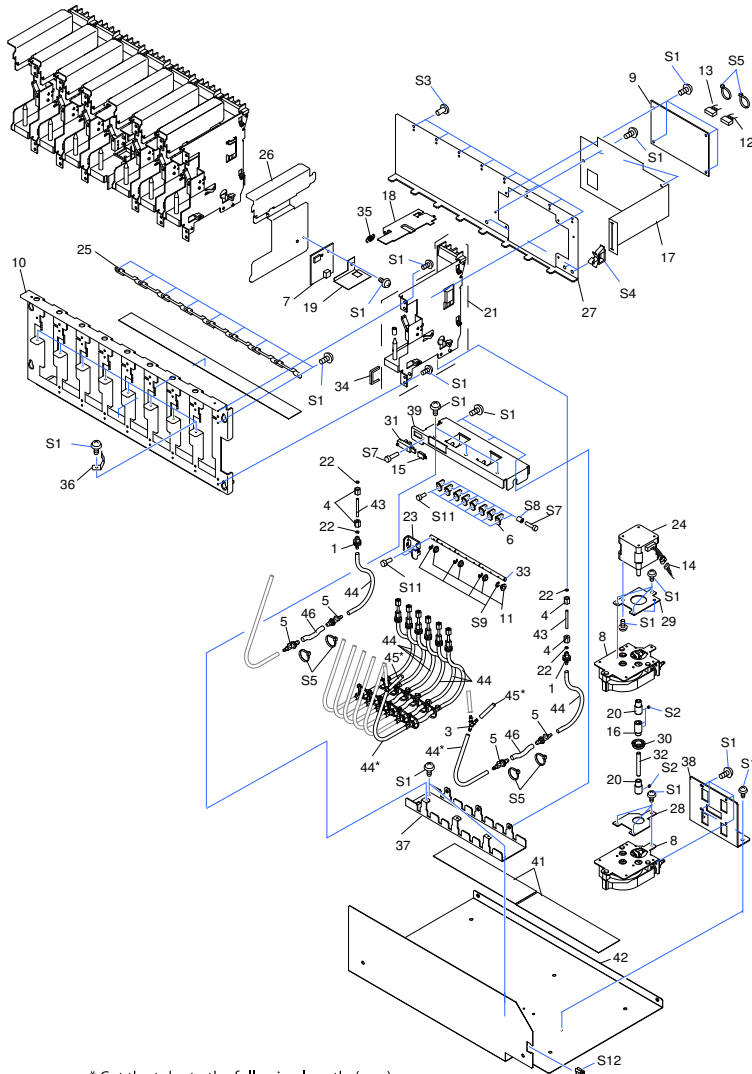

Pos	Code	Description
36	22625103	SPRING,PRESS CARTRIDGE SP-300
37	1000006908	STAY,TUBE VALVE VS-640
38	1000006782	STAY,W-PUMP ASSY VS-640
39	1000006932	SUPPORT,TUBE VALVE VS-640
39	1000011852	SUPPORT,TUBE VALVE 2 VS-640
40	21435109	TUBE,SILICONE 3*5*8 FJ-540
41	1000003089	SHEET,FRAME SUPPORT RAIL VP-540
42	1000006731	COVER,INK CARTRIDGE UNDER VS-640
42	1000007515	COVER,INK CARTRIDGE UNDER VS-540
43	22805572	ASSY,TUBING 2*80MM SP-540V
44	1000007020	ASSY,TUBING 3*200MM VS-640
45	1000007021	ASSY,TUBING 3*500MM VS-640
46	1000007022	ASSY,TUBING 6*42MM VS-640
S1	31289109AS	CUPSCREW SET,M3*4 NI 100 PCS
S2	31199701AS	SCREW SET,SET WP M3*3 NI 20 PCS
S3	31019801	SCREW,BINDING S-TIGHT M3*6 3C 100PCS
S4	3000000560	SADDLE,LOCKING WIRE LWS-0711Z_TH
S4	31409801AS	SADDLE,LOCKING WIRE LWS-0711Z 20P
S5	31329601AS	CLAMP SET,INSULOK T-18S 100 PCS.
S7	31049174AS	SCREW SET,CAP M4*15 NI 20 PCS.
S8	31129102	PIPE SET,POLYCA 4*8*10 20PCS
S9	31149703AS	RING SET,E-RING ETW-4 100 PCS.
S10	31049171AS	SCREW SET,CAP M3*12 NI 50 PCS.
S11	31049142AS	SCREW SET,CAP M3*6 NI MEC 20 PCS
S12	31409702	SADDLE SET,LOCKING WIRE LES-1010 20P

* Cut the tube to the following length. (mm)

Cartridge	Between No.1 Adapter(Ink Cartridge) and Choke No.44	Between Choke and No.2 Adapter No.44*	Between No.3 Y Adapter and Circulate Pump No.45*
	1	90	
2	90		
3	105		
4	105		
5	140		
6	140		
7	180	80	250
8	180	80	250

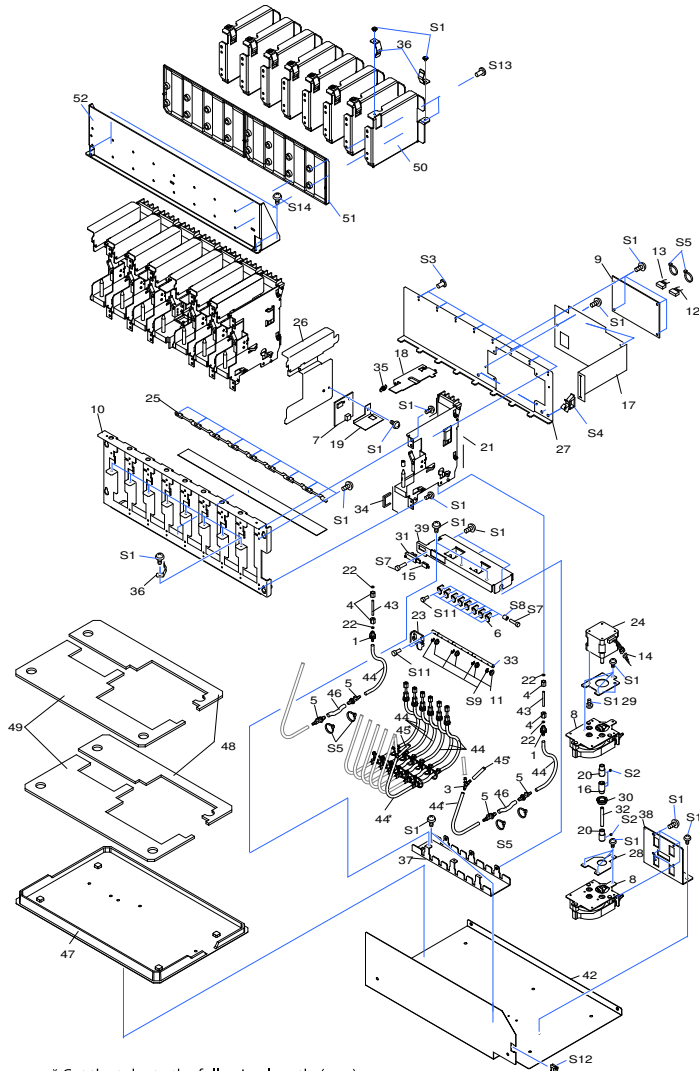

* Cut the tube to the following length. (mm)

Cartridge	Between No.1 Adapter(Ink Cartridge) and Choke No.44	Between Choke No.2 Adapter No.44*	Between No.3 Y Adapter and Circulate Pump No.45*
	1	90	
2	90		
3	105		
4	105		
5	140		
6	140		
7	180	80	250
8	180	80	250

Pos	Code	Description
1	1000004796	ADAPTER,JOINT 2-3FAI RS-540
3	1000002679	ADAPTER,JUNCTION VPY306
4	11909133	ADAPTER,SCREW 2FAI FJ-50
5	1000006327	ADAPTER,TUBE 3-4 LEC-330
5	1000015119	ADAPTER,TUBE 3-4 LEC-330_01
6	1000006909	ARM,TUBE VALVE VS-640
7	W701406070	ASSY,CARTRIDGE IC BOARD VS-640
8	6701219010	ASSY,CIRCULATING PUMP LEC-330
9	W701406030	ASSY,INK TANK BOARD VS-640
10	1000006727	BASE,INK CARTRIDGE VS-640
10	1000009380	BASE,INK CARTRIDGE VS-640_01
11	1000018512	BUSH,80F-0603
11	12159573	BUSH,80F-0603
12	1000006698	CABLE-ASSY,INK IC 1-4 VS-640
13	1000006699	CABLE-ASSY,INK IC 5-8 VS-640
14	1000006700	CABLE-ASSY,MIX PUMP VS-640
15	1000006907	CABLE-ASSY,VALVE SENS VS-640
16	1000002564	COUPLING,PUMP VP-540
17	1000006742	COVER,BOARD I/C VS-640
18	12029300	COVER,HOLDER I/C FJ-50
19	1000007298	COVER,SENSOR I/C VS-640_01
20	1000012988	GEAR,S10B20
20	21685122	GEAR,S10S20
21	6700980300	ASSY,HOLDER I/C RS-540
22	11659149	HOLDER,RING O 2FAI FJ-50
23	1000006911	LEVER,TUBE VALVE VS-640
24	1000018516	MOTOR,103-593-1041
24	22435106	MOTOR,103-593-1041
25	1000006740	PLATE,BASE INK CARTRIDGE VS-640
26	1000006744	PLATE,HOLDER I/C VS-640
27	1000006741	PLATE,INK JOINT2 VS-640
28	1000002595	PLATE,P-BEARING VP-540
29	1000001585	PLATE,P-MOTOR XC-540
29	1000020054	PLATE,P-MOTOR XC-540TH
30	22175815	BEARING F8-16ZZ
31	1000006689	SENSOR-INTERRUPTER,EE-SX4009-P1
32	1000002563	SHAFT,PUMP VP-540
33	1000006910	SHAFT,TUBE VALVE VS-640
34	1000006901	SPACER,INK CARTRIDGE VS-640
35	22175167	SPRING,CARTRIDGE FJ-50

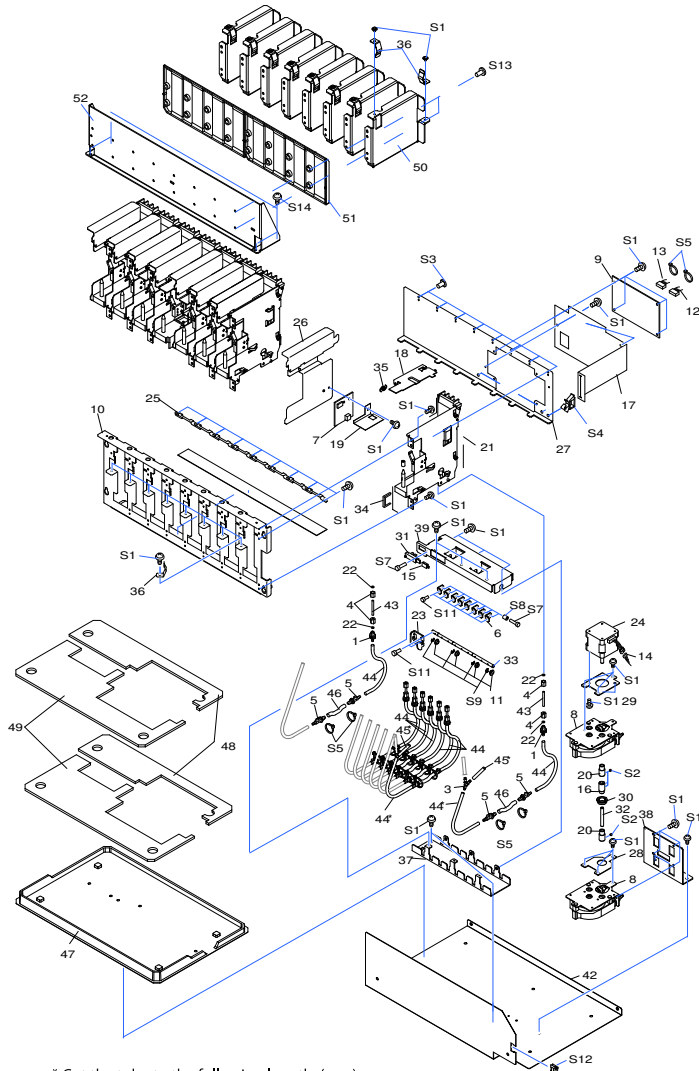

* Cut the tube to the following length. (mm)

Cartridge	Between No.1 Adapter(Ink Cartridge) and Choke No.44	Between Choke and No2 Adapter No.44*	Between No.3 Y Adapter and Circulate Pump No.45*
	1	90	
2	90		
3	105		
4	105		
5	140		
6	140		
7	180	80	250
8	180	80	250

Pos	Code	Description
36	22625103	SPRING,PRESS CARTRIDGE SP-300
37	1000006908	STAY,TUBE VALVE VS-640
38	1000006782	STAY,W-PUMP ASSY VS-640
39	1000006932	SUPPORT,TUBE VALVE VS-640
39	1000011852	SUPPORT,TUBE VALVE 2 VS-640
40	21435109	TUBE,SILICONE 3*5*8 FJ-540
42	1000006731	COVER,INK CARTRIDGE UNDER VS-640
42	1000007515	COVER,INK CARTRIDGE UNDER VS-540
43	22805572	ASSY,TUBING 2*80MM SP-540V
44	1000007020	ASSY,TUBING 3*200MM VS-640
45	1000007021	ASSY,TUBING 3*500MM VS-640
46	1000007022	ASSY,TUBING 6*42MM VS-640
47	1000008562	TRAY,INK VS-640
48	1000008563	PAD,TRAY VS-640
49	1000008564	PAD,TRAY2 VS-640
50	1000008565	PLATE,HOLDER I/C2 VS-640
50	1000015187	PLATE,HOLDER I/C2 VS-640
51	1000008566	PLATE,IC VS-640
52	1000008571	STAY,SPRING PRESS VS-640
S1	31289109AS	CUPSCREW SET,M3*4 NI 100 PCS
S2	31199701AS	SCREW SET,SET WP M3*3 NI 20 PCS
S3	31019801	SCREW,BINDING S-TIGHT M3*6 3C 100PCS
S4	3000000560	SADDLE,LOCKING WIRE LWS-0711Z_TH
S4	31409801AS	SADDLE,LOCKING WIRE LWS-0711Z 20P
S5	31329601AS	CLAMP SET,INSULOK T-18S 100 PCS.
S7	31049174AS	SCREW SET,CAP M4*15 NI 20 PCS.
S8	31129102	PIPE SET,POLYCA 4*8*10 20PCS
S9	31149703AS	RING SET,E-RING ETW-4 100 PCS.
S10	31049171AS	SCREW SET,CAP M3*12 NI 50 PCS.
S11	31049142AS	SCREW SET,CAP M3*6 NI MEC 20 PCS
S12	31409702	SADDLE SET,LOCKING WIRE LES-1010 20P
S13	31289112AS	CUPSCREW SET,M3*10 NI 100 PCS.
S14	31289102AS	CUPSCREW SET,M3*6 NI 50 PCS.

Pos	Code	Description
1	22805572	ASSY,TUBING 2*80MM SP-540V
2	1000007020	ASSY,TUBING 3*200MM VS-640
3	1000007022	ASSY,TUBING 6*42MM VS-640
4	1000007210	TUBE,SJ-RDG3*4 LINK6 VS-540
4	1000009883	TUBE,SJ-RDG3*4 LINK6 VS-540_01
5	1000007211	TUBE,SJ-RDG3*4 LINK4 VS-540
5	1000009887	TUBE,SJ-RDG3*4 LINK4 VS-540_01

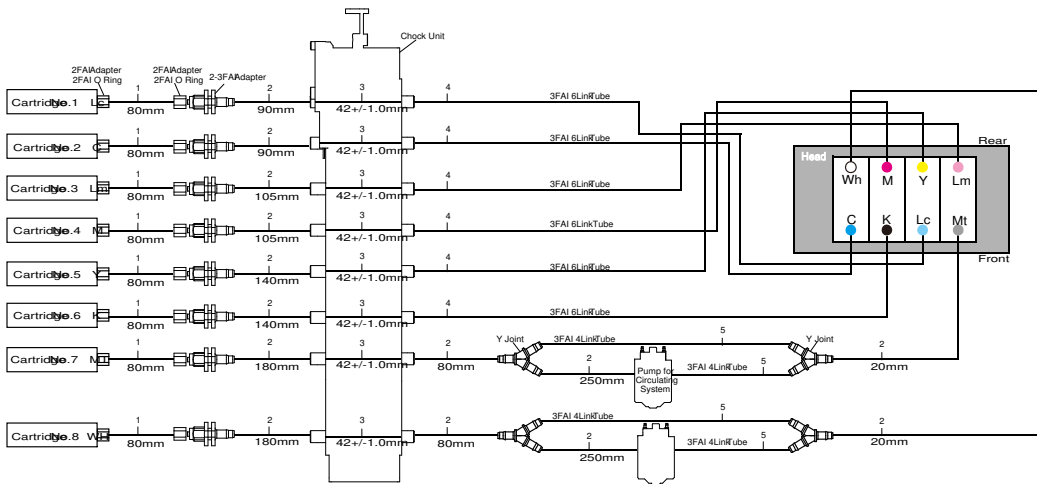

Pos	Code	Description
1	22805572	ASSY,TUBING 2*80MM SP-540V
2	1000007020	ASSY,TUBING 3*200MM VS-640
3	1000007022	ASSY,TUBING 6*42MM VS-640
4	1000007210	TUBE,SJ-RDG3*4 LINK6 VS-540
4	1000009883	TUBE,SJ-RDG3*4 LINK6 VS-540_01
5	1000007211	TUBE,SJ-RDG3*4 LINK4 VS-540
5	1000009887	TUBE,SJ-RDG3*4 LINK4 VS-540_01

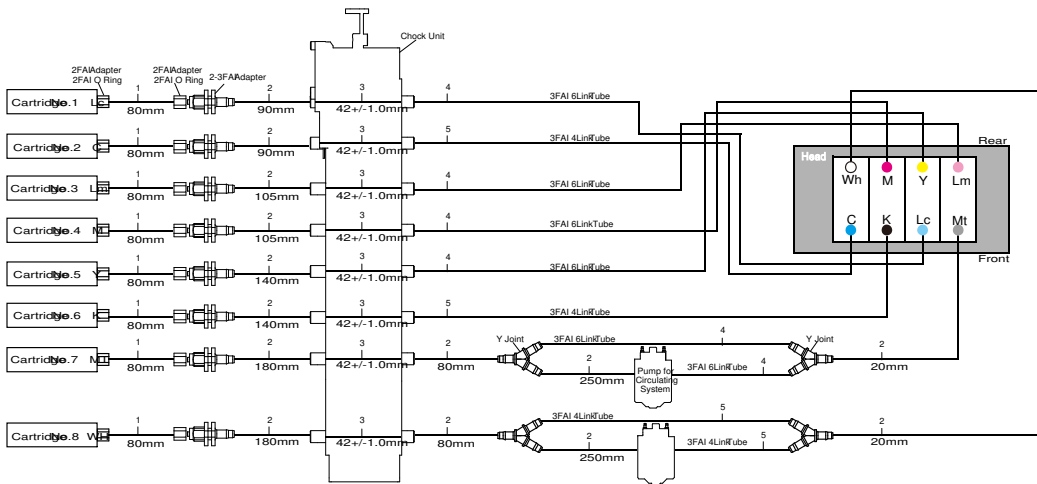

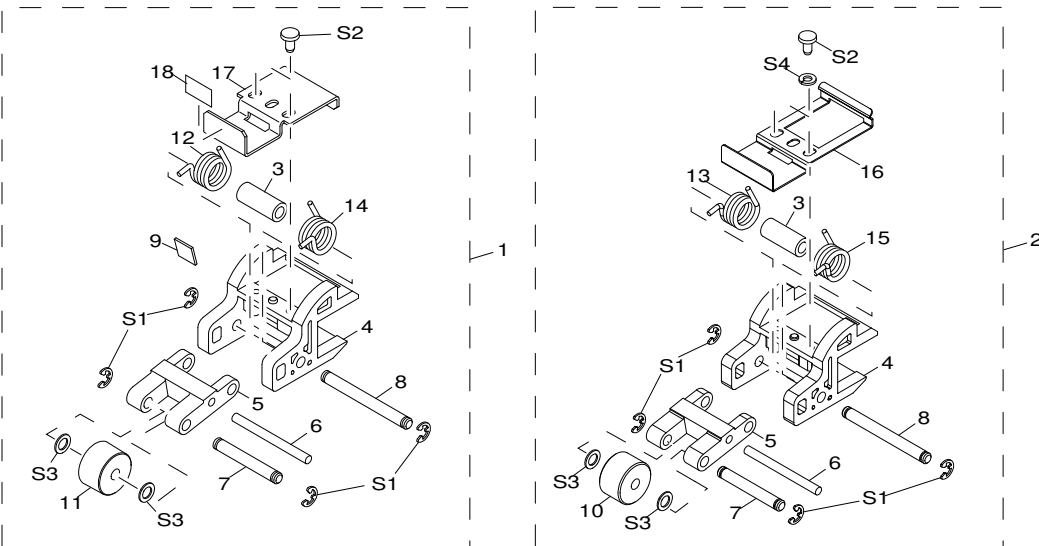

Pos	Code	Description
1	1000015670	ASSY,PINCHROLL R SG-540
1	1000015671	ASSY,PINCHROLL L SG-540
1	6000005177	ASSY,PINCHROLL R VG-640
1	6000005178	ASSY,PINCHROLL L VG-640
1	6700460210	ASSY,PINCHROLL L VP-540
1	6700460220	ASSY,PINCHROLL R VP-540
2	1000015672	ASSY,PINCHROLL C SG-540
2	6000005176	ASSY,PINCHROLL C VG-640
2	6700460300	ASSY,PINCHROLL C VP-540
3	1000020065	COLLAR,P-ROLLER PNC-960TH
3	21745101	COLLAR,P-ROLLER PNC-960
4	22195153	FRAME,PINCH ROLL SP-540V
5	22145416	LEVER,P-ROLLER PNC-960
6	11539104	PIN 3*35 SUS M6
7	1000020050	SHAFT,1 GRX-400TH
7	22145831	PIN NO.1 (214-831)
8	1000020051	SHAFT,2 GRX-400TH
8	22145832	PIN NO.2 214-832
9	22055264	PLATE,GUIDE P PNC-960
10	21565103	P-ROLLER FD16S4(B10) TYPE2
10	6000003823	ASSY,P-ROLLER FD16S4(B10) TYPE 2_01
11	21565102	P-ROLLER TD16S4(B10) TYPE2
11	6000003824	ASSY,P-ROLLER TD16S4(B10) TYPE 2_01
12	22625101	SPRING,PINCH LEFT SP-300
13	1000002648	SPRING,PINCH LEFT VP-540
14	22625102	SPRING,PINCH RIGHT SP-300
15	1000002649	SPRING,PINCH RIGHT VP-540
16	22715461	STAY,PINCH CENTER SP-540V
17	1000003028	STAY,PINCH SENSOR VP-540
18	1000002973	LABEL,PINCH SENSOR VP-540 #LA979
S1	31149702AS	RING SET,E-RING ETW-3 100 PCS.
S2	31019702AS	SCREW SET,BIND P-TIGHT M3*6 3C 100P
S3	31249211AS	WASHER SET,PLAIN 4.3*7*0.5 NI 100P
S4	31249303	WASHER SET,SPRING M3 NI 100 PCS

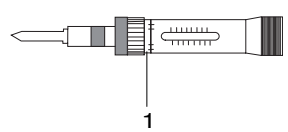

1

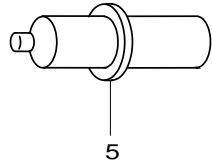

5



9

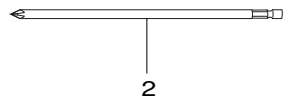

2

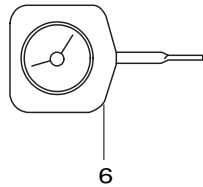

6

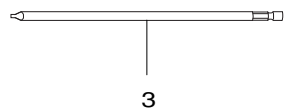

3

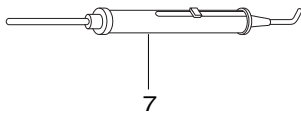

7

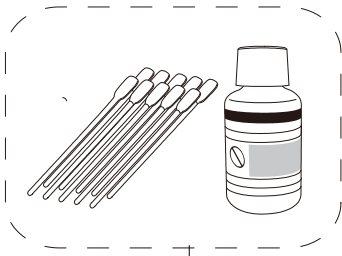

10

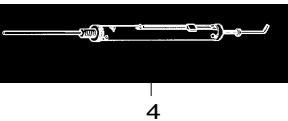

4

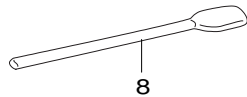

8

Pos	Code	Description
1	ST-056	TORQUE DRIVER N6
2	1000005463	TOOL,BIT PHILLIPS NO.1 L150MM ST-107
3	1000006902	TOOL,BIT HEXAGONAL ST-118
4	ST-002	TENSION GAUGE 300GF/300CN
5	ST-006	WHITE DUMMY PEN
6	ST-013	DIAL TENSION METER DT-100
7	ST-001	TENSION GAUGE 2000GF/2000CN
8	1000003138	SET,CLEANER STICK TX712A 10PCS.
8	1000007172	CLEANER SET,STICK TX712A 100PCS
8	ST-037	CLEAN STICK TX712A
9	21755107	CLEANING LIQUID(SL) 500ML
9	6702419050	CLEANING LIQUID(ESL5) 500ML
10	22085118	KIT,CLEANING(SL)
10	6701409310	KIT,CLEANING(ESL5) 100ML

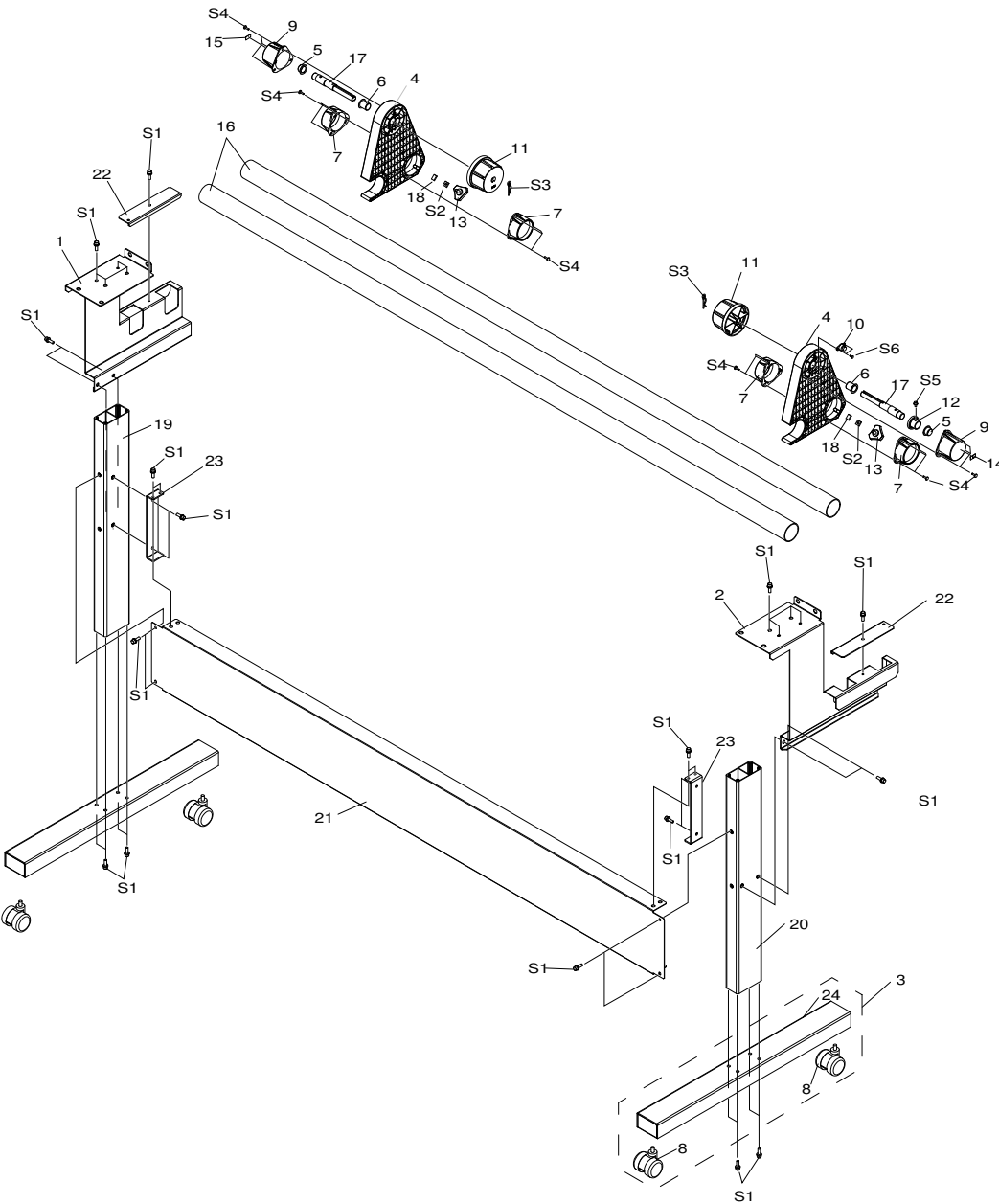

Pos	Code	Description
1	1000006779	ARM,L VS-640
2	1000006778	ARM,R VS-640
3	1000006533	ASSY,BASE STAND VS-640
4	1000004718	BASE,FEEDER RS-540
5	1000001068	BUSH,80F-1610
6	1000001352	BUSH,80F-1620
6	1000018502	BUSH,80F-1620
7	1000004720	BUSH,FEEDER R RS-540
8	12329505	CASTER,BWS-50BN
9	1000004719	COVER,FEEDER RS-540
10	1000004734	DAMPER,FRT-C2-301G1
11	1000001584	FLANGE,GUIDE 3 XC-540
12	1000004722	GEAR,S32(B5M0.8) RS-540
13	1000003545	KNOB,BOLT 117-10313
14	1000001090	LABEL,CLAMP L AJ-1000#LA913
15	1000001089	LABEL,CLAMP R AJ-1000#LA912
16	1000004725	PIPE,FEEDER SHAFT RS-540
17	1000004721	SHAFT,FEEDER RS-540
18	1000005480	SPACER,BASE FEEDER RS-540
19	1000006812	STAND,LEG L VS-640
20	1000006811	STAND,LEG R VS-640
21	1000007198	STAY,STAND VS-540
22	1000003635	STOPPER,PIPE FEEDER XJ-740
23	1000006824	SUPPORT,STAY STAND VS-640
24	1000007016	STAND,BASE VS-640
S1	31049157	SCREW,CAP M6*20 3CBC+PW+SW
S2	3000000110	NUT SET,SQUARE M6*11*3 3C 50PCS
S3	31119701	PIN,SNAP M14 SUS
S4	3000000124	SCREW SET,BIND P-TIGHT4*12 3CBC 50PCS
S5	31049169AS	SCREW SET,CAP M4*8 3CBC+PW 20PCS
S6	31019703	SCREW,BINDING P-TIGHT M3*8 3C 100P

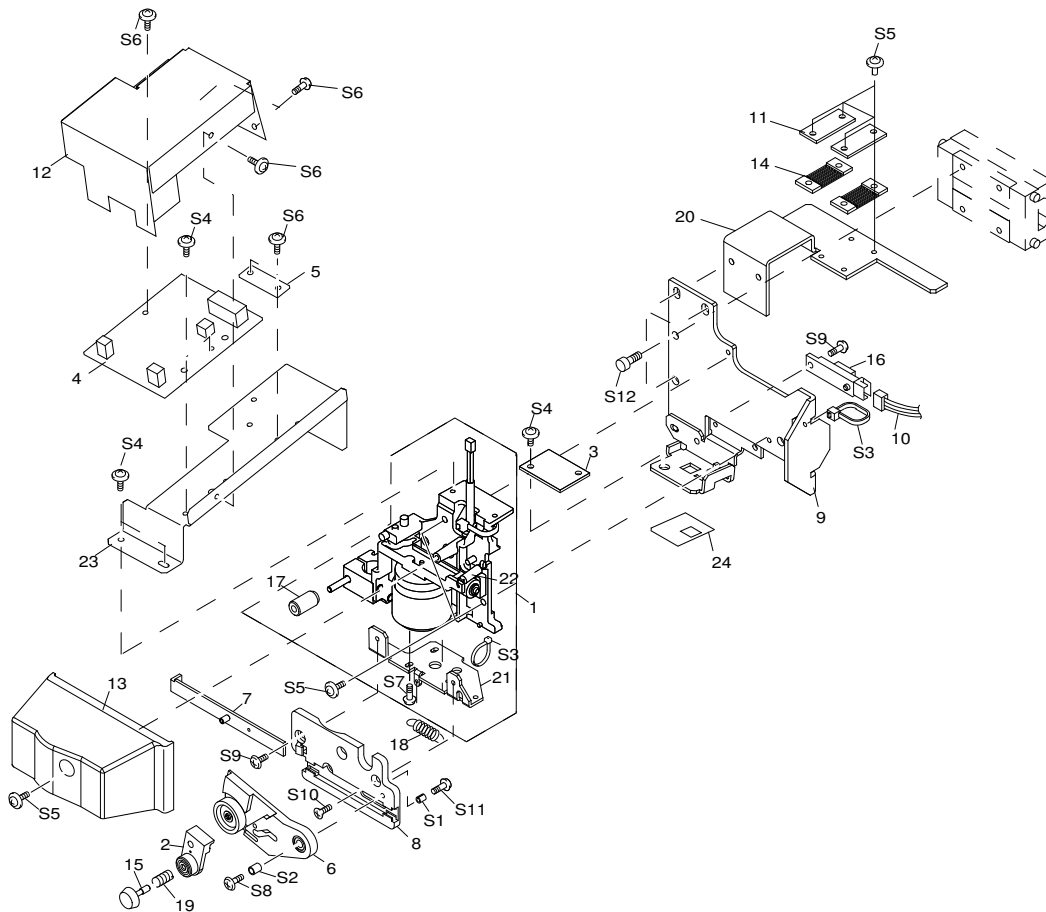

Pos	Code	Description
1	1000013547	ASSY,CARRIAGE SP-300_02
1	22805571	ASSY,CARRIAGE SP-300
2	22805292	ASSY,CLAMP BLADE SV CM-500
3	W701406050	ASSY,CROP SENS VS-640
4	W701407020	ASSY,CUT CARRIAGE BOARD VS-640
4	W701407021	ASSY,CUT CARRIAGE BOARD VS-640_01
5	W701406090	ASSY,FLEX 1 VS-640
6	22805291	ASSY,HOLDER BLADE SV CM-500
7	22805287	ASSY,PLATE CAM SLIDE SV CM-500
8	7488739000	BASE CUTTER CJ-500
9	1000006776	BASE,CUT CARRIAGE VS-640
10	1000002185	CABLE-ASSY,PINCH SENSOR VP-540
11	1000020055	COVER,BELT HOLDER EGX-600TH
11	22025646	COVER,BELT HOLDER EGX-600
12	1000002570	COVER,CARRIAGE BOARD VP-540
13	22025269	COVER,CARRIAGE CM-500
14	1000015114	HOLDER,BELT EGX-600_01
14	21655232	HOLDER,BELT EGX-600
15	21495115	SCREW,BLADE SET CM-500
16	15099115	SENSOR-INTERRUPTER GP2A25NJ
17	22285503	NUT,PENHOLDER
18	1000012947	SPRING,BLADE UP CM-500
18	22175154	SPRING,BLADE UP CM-500
19	1000012948	SPRING,SCREW CM-500
19	22175155	SPRING,SCREW CM-500
20	1000002540	STAY,HOLDER BELT VP-540
21	22715168	STAY,AUTO CUTTER 2 CM-500
22	22175122	SPRING,BACK UP PNC-960
23	1000002531	STAY,CUT CARRIAGE BOARD VP-540
24	1000009137	SHEET,FILTER CROP VS-640
S1	31029801AS	BUSH SET,ROLL 2*4 3C100PCS
S2	31029803AS	BUSH SET,ROLL 3*5 3C 20PCS.
S3	31329601AS	CLAMP SET,INSULOK T-18S 100 PCS.
S4	31289109AS	CUPSCREW SET,M3*4 NI 100 PCS
S5	31289102AS	CUPSCREW SET,M3*6 NI 50 PCS.
S6	31299102AS	RIVET SET,NYLON P2655B 20 PCS.
S7	31019148AS	SCREW SET,BINDING M2.6*4 NI 100 PCS
S8	31019118AS	SCREW SET,BINDING M3*10 3CBC 100PCS
S9	31019116AS	SCREW SET,BINDING M3*6 3CBC 100 PCS
S10	31169103AS	SCREW SET,FLAT M3*6 3CBC 100 PCS

Pos	Code	Description
S11	31229103AS	SCREW SET,TRUSS M2*6 NI 100 PCS
S12	31069104	SCREW,CAP M4*6+FL NI

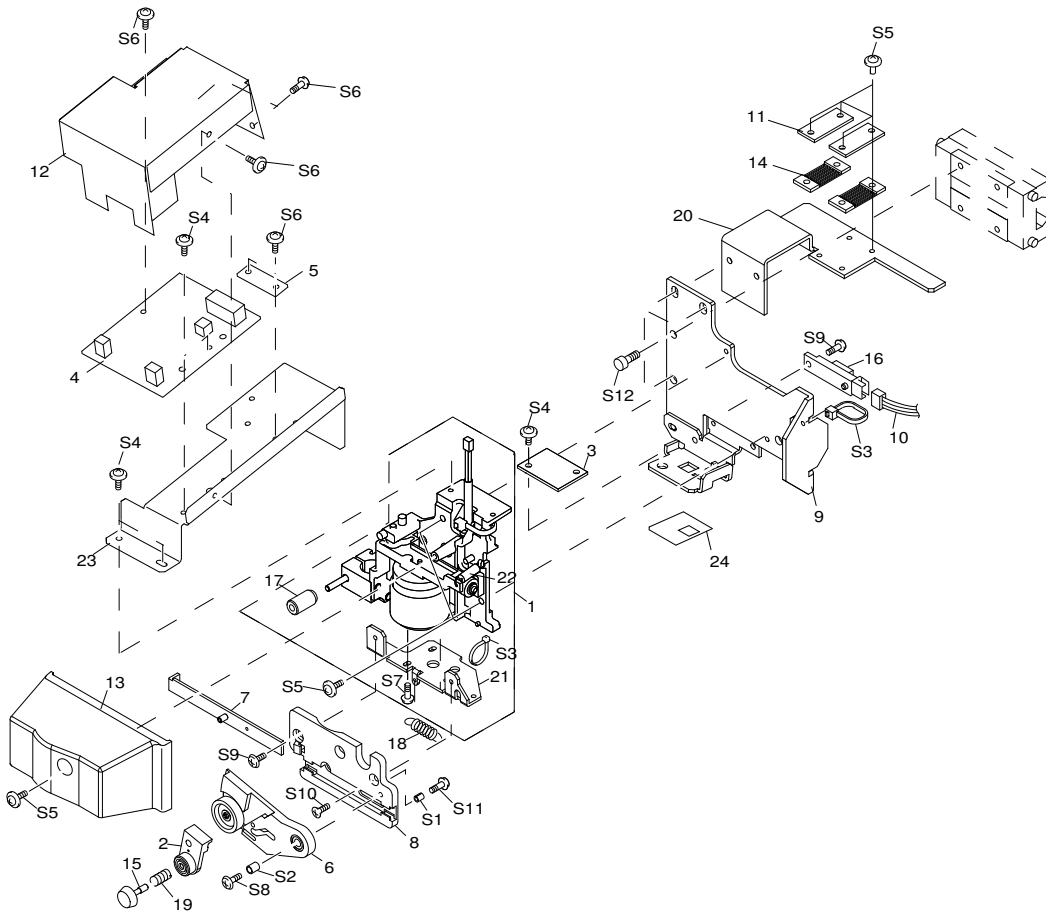

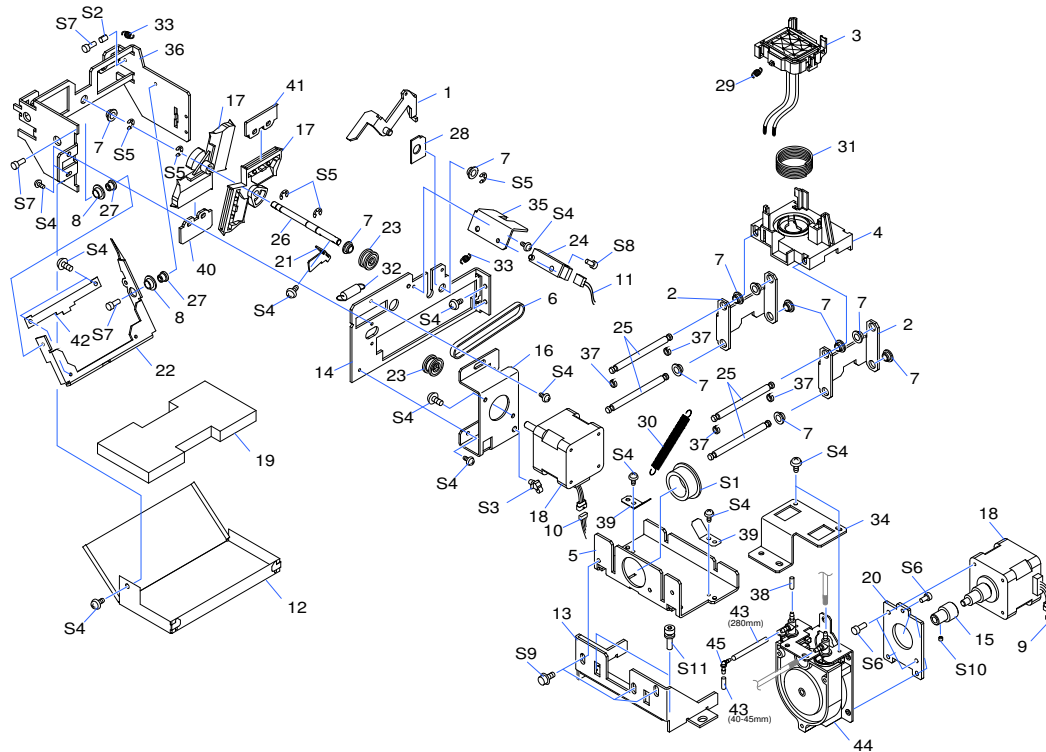

Pos	Code	Description
1	100009369	ARM,WIPER CAM VS-640_01
2	100006747	ARM,LINK UP VS-640
2	1000019619	ARM,LINK UP VS-640TH
3	6701409200	ASSY,CAP TOP VS-640_01
4	100006521	BASE,BACK-UP CAP VS-640
4	1000012824	BASE,BACK-UP CAP VS-640_01
5	100006748	BASE,CAP VS-640
6	100006725	BELT,172P2M4-530
7	1000000796	BUSH,80F-0503
7	1000018501	BUSH,80F-0503
8	1000018512	BUSH,80F-0603
8	12159573	BUSH,80F-0603
9	100006697	CABLE-ASSY,PUMP MOTOR VS-640
10	1000002182	CABLE-ASSY,WIPER MOTOR VP-540
11	100006693	CABLE-ASSY,WIPER SENS VS-640
12	100006754	COVER,WIPE UNDER VS-640
13	100006749	FRAME,BASE CAP VS-640
14	100009368	FRAME,WIPER VS-640_01
15	100006751	GEAR,S14S5(B12)
16	100006723	HOLDER,WIPE MOTOR VS-640
16	1000019620	HOLDER,WIPE MOTOR VS-640TH
17	100006519	HOLDER,WIPER VS-640
18	1000018516	MOTOR,103-593-1041
18	22435106	MOTOR,103-593-1041
19	100006755	PAD,WIPE VS-640
20	100006750	PLATE,P-MOTOR VS-640
20	1000015185	PLATE,P-MOTOR VS-640
21	100006726	PLATE,SENS WIPER VS-640
22	100006738	PLATE,WIPE SCRAPER VS-640
23	22565406	DRIVE PULLEY
24	100006689	SENSOR-INTERRUPTER,EE-SX4009-P1
25	100006746	SHAFT,CAP VS-640
26	100006735	SHAFT,WIPER VS-640
26	1000019621	SHAFT,WIPER VS-640TH
27	22165178	SPACER,6FAI FJ-50
28	100009370	SPACER,ARM WIPER VS-640_01
29	100006524	SPRING,CAP FRONT VS-640
29	1000015181	SPRING,CAP FRONT VS-640
30	100006825	SPRING,CAP SWING VS-640
31	100006523	SPRING,CAP VS-640

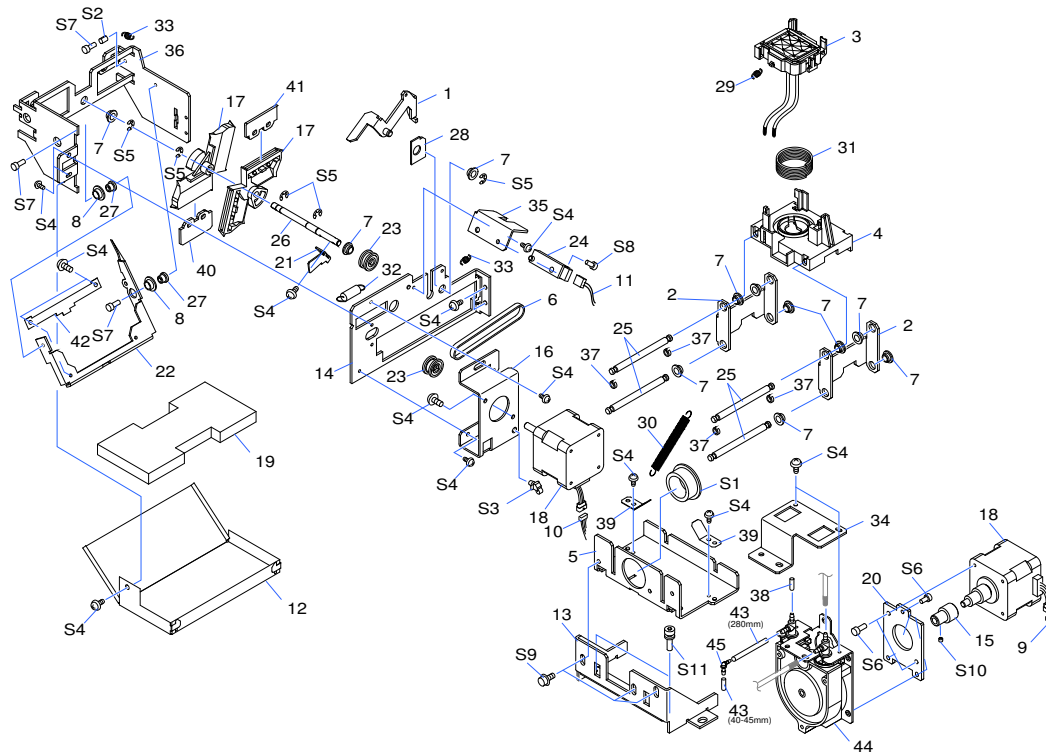

Pos	Code	Description
31	100007551	SPRING,CAP VS-640_01
31	1000015182	SPRING,CAP VS-640_01
32	22175521	SPRING,PINCH 930 FJ-540
33	1000006518	SPRING,SCRAPER VS-640
34	1000006773	STAY,PUMP ASSY VS-640
35	1000006724	STAY,WIPE SENSOR VS-640
36	1000006720	STAY,WIPER SCRAPER VS-640
37	22135349	STOPPER,PEN-HOLDER CM-24
38	1000002019	STOPPER,PUMP XC-540
39	1000002645	STOPPER,SHAFT CAP VP-540
40	1000006736	WIPER,HEAD FELT VS-640
41	1000006517	WIPER,HEAD VS-640
42	1000006737	WIPER,SCRAPER VS-640
43	1000002119	TUBE,EPDM ID2-OD4 310MM
43	1000014965	TUBE,CUT SJ-RDG 2.2*3.2 500MM (MAX3)
43	3000000053	TUBE,EPDM ID2-OD4 100M
43	6000004089	TUBE,EPDM ID2-OD4 310MM_02
44	6700319010	ASSY,PUMP SUB XC-540
45	1000008314	ADAPTER,JOINT 2L MCL-1
S1	31029101	BUSH,NB-19
S2	31029803AS	BUSH SET,ROLL 3*5 3C 20PCS.
S3	31329501AS	CLAMP SET,PUSH MOUNT RT30SSF5 20P
S4	31289109AS	CUPSCREW SET,M3*4 NI 100 PCS
S5	31149703AS	RING SET,E-RING ETW-4 100 PCS.
S6	31049142AS	SCREW SET,CAP M3*6 NI MEC 20 PCS
S7	31049170AS	SCREW SET,CAP M3*8 NI 50 PCS.
S8	31049173AS	SCREW SET,CAP M4*10 NI 50 PCS.
S9	31049169AS	SCREW SET,CAP M4*8 3CBC+PW 20PCS
S10	31199701AS	SCREW SET,SET WP M3*3 NI 20 PCS
S11	31179106	SCREW,JACK UP SP-540V

Pos	Code	Description
43	1000006907	CABLE-ASSY, VALVE SENS VS-640
44	1000004149	FILTER(E), FRC-40-12-1.7-013

