

Pos	Code	Description
1	1000015713	PAD,FEEDER SG-540
1	1000017519	PAD,FEEDER SV SG-540
2	1000015145	PAD,STAND VG-640
2	1000015714	PAD,STAND SG-540
2	1000017510	PAD,STAND SV SG-540
3	1000021064	CARTON,STAND VG-640_TH
4	1000014611	PAD,PIPE FEEDER SHAFT EJ-640
4	1000015711	PAD,PIPE FEEDER SHAFT SG-540
4	1000017508	PAD,PIPE FEEDER SHAFT SV SG-540
5	1000015716	CARTON,SLEEVE SG-540
5	1000017512	CARTON,SLEEVE SV SG-540
6	1000018803	PAD,SPACER RAIL CG2023
7	1000021066	CARTON,SPACER VG-540_TH
8	1000020823	PAD,L-LEFT CG2076_TH
9	1000020824	PAD,L-RIGHT CG2076_TH
10	1000015726	PAD,CENTER SG-540
10	1000017521	PAD,CENTER SV SG-540
11	1000015718	CARTON,COVER SG-540
11	1000017513	CARTON,COVER SV SG-540
12	1000018196	TRAY,SKID SG-540_01
12	1000019080	TRAY,SKID SV SG-540_01
13	1000015150	PAD,U-LEFT VG-640
13	1000015719	PAD,U-LEFT SG-540
13	1000017514	PAD,U-LEFT SV SG-540
14	1000015151	PAD,U-RIGHT VG-640
14	1000015730	PAD,U-RIGHT SG-540
14	1000017518	PAD,U-RIGHT SV SG-540
15	1000015721	PAD,VKIT SG-540
15	1000017522	PAD,VKIT SV SG-540
16	1000015712	PAD,SUPPORT FEEDER SHAFT SG-540
16	1000017509	PAD,SUPPORT FEEDER SHAFT SV SG-540
17	1000015731	PAD,ACCESSORY SG-540
17	1000017523	PAD,ACCESSORY SV SG-540
18	1000017872	PAD,SUPPORT VG-540T

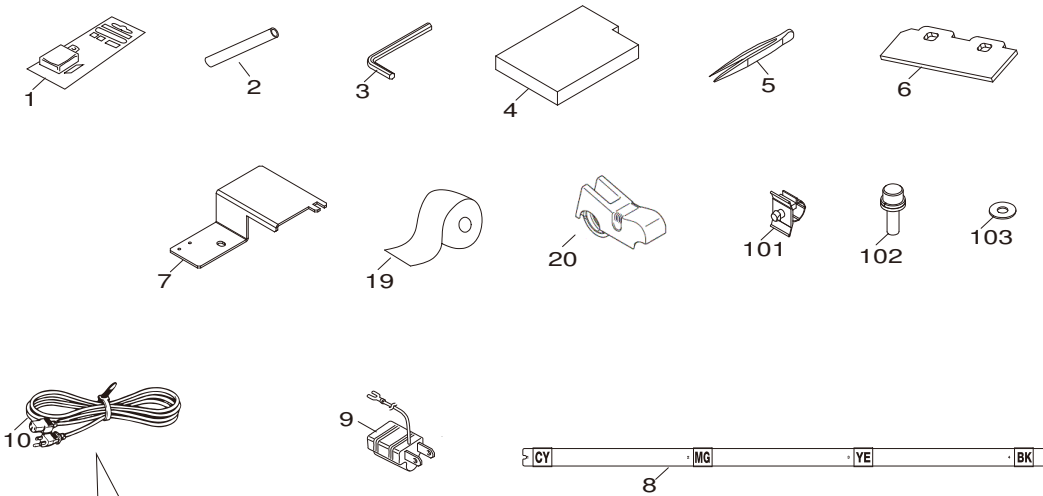

Pos	Code	Description
1	11849102	BLADE,OLFA AUTO CUTTER XB10
2	22155133	PIPE,TOOL D9*L150 FJ-540
3	22565682	HEXAGONAL WRENCH 5
4	1000020059	PAD,CLEANER D VG-640TH
5	12569656	TWEEZERS PTS-01
6	1000014754	WIPER,HEAD VG-640
7	1000019053	STOPPER,CARRIAGE CG2076 TH
8	1000018948	LABEL, SET INK SG-540#LA3239
9	13499209	ADAPTER PLUG (100V)
10	1000005832	CABLE-AC,100V 15A 2.5M 3P
11	1000005833	CABLE-AC,117V 15A 2.5M 3P
12	13439801	CABLE-AC 3P CHINA 10A250V S
13	1000010999	CABLE-AC, H05VV 230V 10A KC
14	1000006571	CABLE-AC,3P 117/230V BR 2.5M
15	23495125	AC-CORD H05VV 230V 10A S
16	1000006097	CABLE-AC,3P 230VAR 2.5M TW
17	13499111	AC CORD H05VV-F 240VE 10A S
18	23495124	AC CORD 3ASL100 240VA 10A SAA
19	3000000437	SHEET,CHECK ALI EJ-640
20	1000019676	SUPPORT,ROLL MEDIA CG2076
101	31379111	CLAMP,CABLE CKS-13-H
102	31049157	SCREW,CAP M6*20 3CBC+PW+SW
103	31249220AS	WASHER SET,PLAIN 6.5*16*1 NI 100PCS

117V 11	250VC 12	230VK 13	230V BR 14
230V 15	230V AR 16	240VE 17	240VA 18

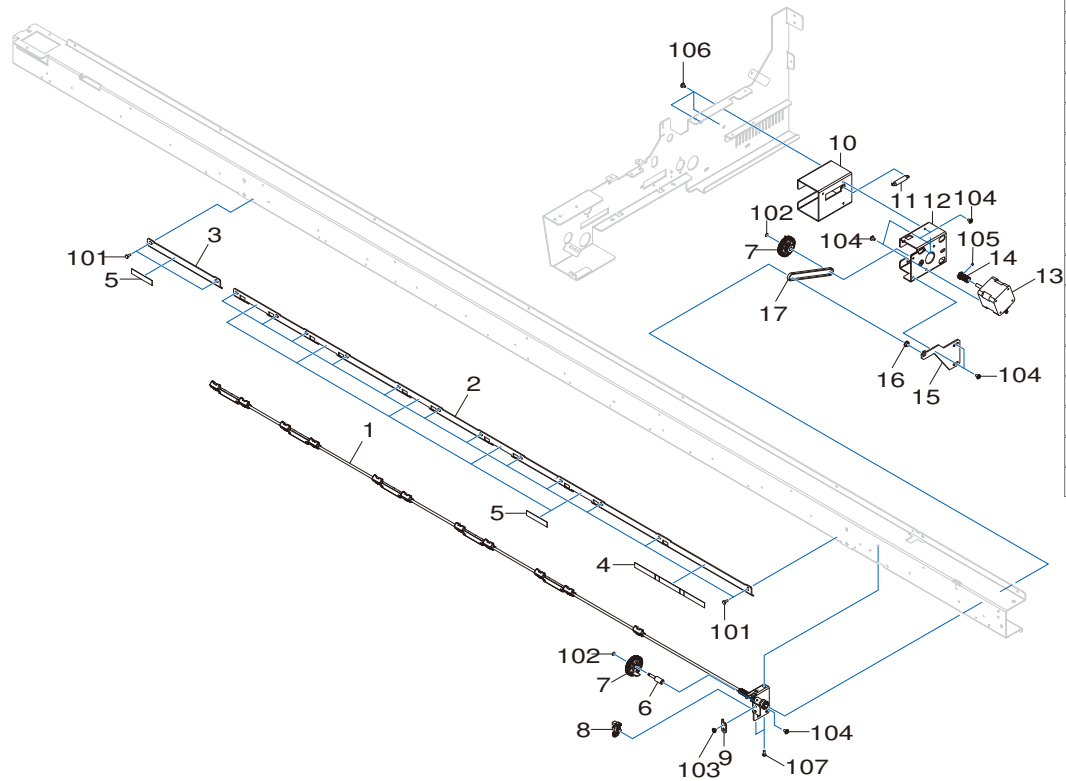

Pos	Code	Description
2	1000018799	PLATE,PINCH DOWN STOPPER CG2075
3	1000018800	PLATE,PINCH DOWN STOPPER L CG2075
4	1000002971	LABEL,G-ROLLER 170 VP-540 #LA978
5	1000002970	LABEL,G-ROLLER 50 VP-540 #LA977
6	1000018599	SHAFT,A-PINCH ORIGIN CG2023
7	1000018964	GEAR,A-PINCH DRIVE 2 CG2023
8	1000016994	SENSOR-INTERRUPTER,EE-SX4235A_P2
9	1000018777	HOLDER,SHAFT A-PINCH R CG2076
10	1000019045	BASE,GEAR A-PINCH 2 CG2023
11	1000014907	SPRING,PINCH 2000 AJ-1000
12	1000019659	STAY,GEAR A-PINCH CG2076
13	1000018514	MOTOR,103-5208-85542
14	1000018965	GEAR,A-PINCH MOTOR 2 CG2023
15	1000019657	SUPPORT,BELT A-PINCH CG2076
16	1000018501	BUSH,80F-0503
17	1000007153	BELT,244P2M4-530
101	31019117AS	SCREW SET,BINDING M3*8 3CBC 100 PCS
102	31249952	WASHER SET,POLYSLIDER 2.6*5*.5 CUT 20PCS
103	31289109AS	CUPSCREW SET,M3*4 NI 100 PCS
104	31289102AS	CUPSCREW SET,M3*6 NI 50 PCS.
105	31199701AS	SCREW SET,SET WP M3*3 NI 20 PCS
106	31289105AS	CUPSCREW SET, M3*6 3CBC 100 PCS
107	31049155AS	SCREW SET,CAP M3*12 BC+PW 20 PCS.

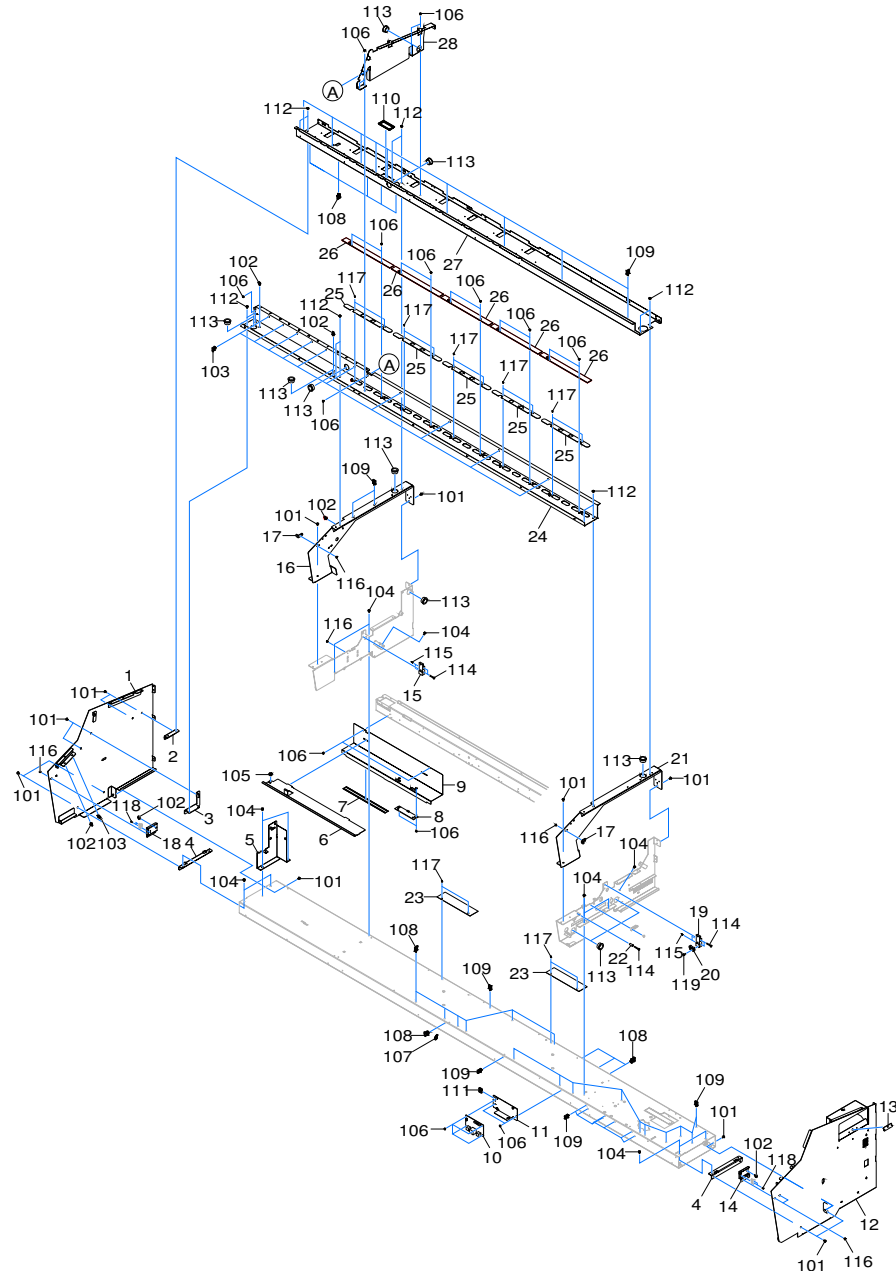

Pos	Code	Description
1	1000019706	FRAME,SIDE L CG2076
2	1000017551	STAY,INK CARTRIDGE PLATE CG2032
3	1000017552	STAY,SUPPORT COVER CG2032
4	1000015317	STAY,FRAME SG-540
5	1000015311	STAY,SUPPORT RAIL L SG-540
6	1000015314	FRAME,AUTOCUTTER SG-540
7	1000014596	SHEET,BED LED VG-640
8	6000004236	ASSY,MAINTENANCE LIGHT BOARD CG2075
9	1000015319	STAY,MAINTENANCE LED SG-540
10	W704890110	ASSY,EXT IF CG2075_01
11	1000020992	STAY,EXT PORT CG2092
12	1000019705	FRAME,SIDE R CG2076
13	1000014825	LABEL,CL VG-640#LA2170
14	1000015411	COVER,SW R SG-540
15	1000018963	BASE,RAIL CG2023
16	1000021389	SUPPORT,FRAME L2 CG2076
17	1000015316	STAY,COVER ARM SG-540
18	1000015412	COVER,SW L SG-540
19	1000018963	BASE,RAIL CG2023
20	1000018956	HOLDER,SHAFT A-PINCH C CG2023
21	1000019679	SUPPORT,FRAME CG2076
22	1000020065	COLLAR,P-ROLLER PNC-960TH
23	1000019675	PLATE,SUPPORT FAN CG2076
24	1000020770	SUPPORT,COVER CG2092
25	1000019653	SHEET,DIFFUSION LED CG2076
26	6000004235	ASSY,LED LIGHT BOARD CG2075
27	1000020769	PLATE,INK CARTRIDGE CG2092
28	1000017363	COVER,SIDE INK SYSTEM CG2032
101	31289110AS	CUPSCREW SET, M4*8 3CBC 100 PCS
102	31329501AS	CLAMP SET,PUSH MOUNT RT30SSF5 20P
103	3000000560	SADDLE,LOCKING WIRE LWS-0711Z_TH
104	3000000172	SCREW SET,CAP M4*8 NI WSH4*9*0.8 20P
105	31139104	SCREW,PLAPOINT M4*6 BK FE
106	31289102AS	CUPSCREW SET,M3*6 NI 50 PCS.
107	31329601AS	CLAMP SET,INSULOK T-18S 100 PCS.
108	31409811AS	SADDLE SET,LOCKING WIRE LWS-1211Z 20P
109	3000000216	SADDLE,WIRE WS-2N-V0
110	31029106	BUSH,SQUARE SB-6025
111	31409702	SADDLE SET,LOCKING WIRE LES-1010 20P
112	31289111AS	CUPSCREW SET, M4*6 NI 100 PCS.

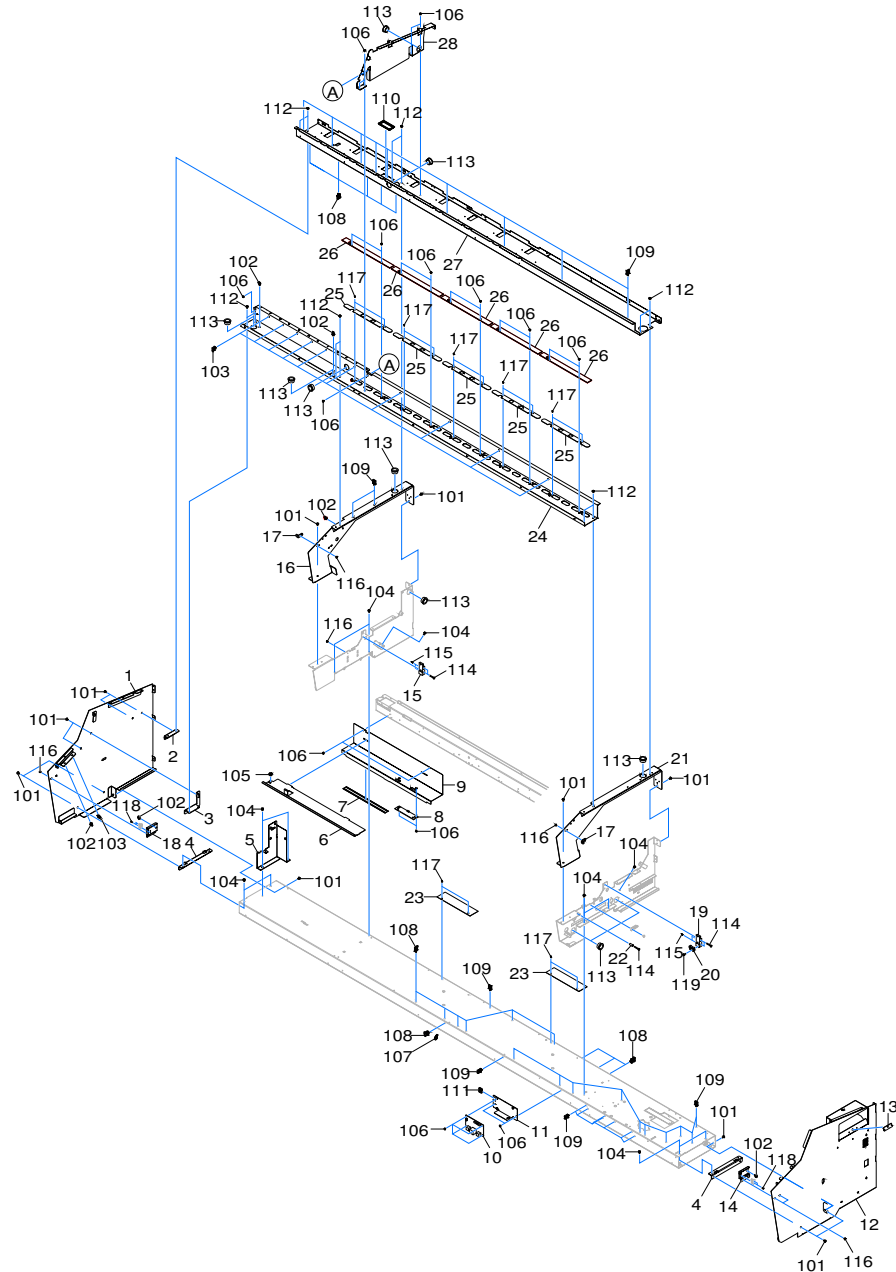

Pos	Code	Description
113	31029101	BUSH,NB-19
114	3000000423	CAP-SCREW,4*25 3CBC 100PCS
115	31119904	PIN,SPRING 2.5*8 SUS STRAIGHT 50 PCS
116	31289105AS	CUPSCREW SET, M3*6 3CBC 100 PCS
117	31299102AS	RIVET SET,NYLON P2655B 20 PCS.
118	31019149	SCREW SET,BINDING M2.3*8 3CBC 100PCS
119	3000000424	CAP-SCREW,3*12NI WSH 3*6*0.5

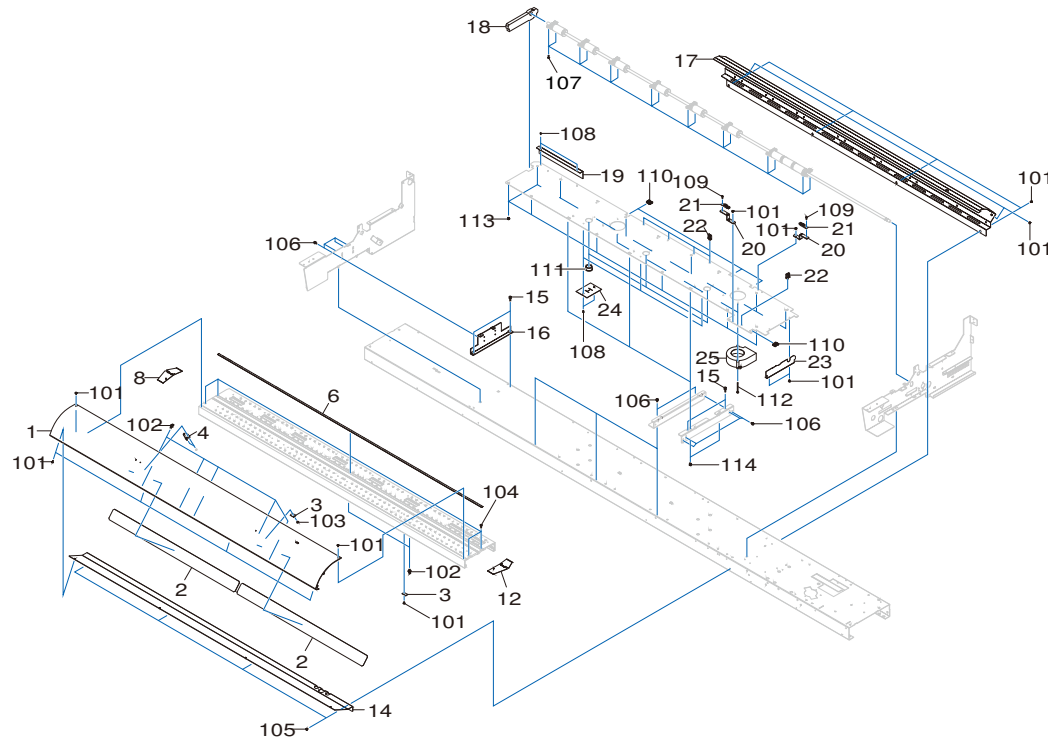

Pos	Code	Description
1	1000015343	ASSY,APRON F SG-540
2	1000002165	ASSY,CORD HEATER VP-540
3	1000015534	ASSY,THERMISTOR BOARD SG-540
4	1000013820	SENSOR,03EN 9572 A65
6	1000020748	PAD,CUTTER 2 VG-540
8	6000005192	ASSY,CLAMP MEDIA L SV VG2-640
12	6000005193	ASSY,CLAMP MEDIA R SV VG2-640
14	1000017444	APRON,F UNDER CG2032
15	31179106	SCREW,JACK UP SP-540V
16	1000021084	FRAME,SIDE BED 2 CG2076
17	1000019729	APRON,B CG2075
18	1000010086	SHUTTER,BED L XF-640
19	1000019674	PLATE,SHUTTER BED REAR CG2076
20	1000020057	STAY,PAPER SENSOR XF-640TH
21	15099115	SENSOR-INTERRUPTER GP2A25NJ
22	3000000216	SADDLE,WIRE WS-2N-V0
23	1000019664	SHUTTER,BED R CG2076
24	1000012964	SHUTTER,HEATER CORD SP-300
25	1000018515	FAN,9BAM24P2H06PJ
101	31289102AS	CUPSCREW SET,M3*6 NI 50 PCS.
102	31329501AS	CLAMP SET,PUSH MOUNT RT30SSF5 20P
103	31289109AS	CUPSCREW SET,M3*4 NI 100 PCS
104	3000000426	CAP-SCREW,4*10 NI 100PCS
105	31289105AS	CUPSCREW SET, M3*6 3CBC 100 PCS
106	3000000172	SCREW SET,CAP M4*8 NI WSH4*9*0.8 20P
107	31289112AS	CUPSCREW SET,M3*10 NI 100 PCS.
108	31299102AS	RIVET SET,NYLON P2655B 20 PCS.
109	3000000425	CAP-SCREW,3*8 NI 100PCS
110	31409702	SADDLE SET,LOCKING WIRE LES-1010 20P
111	31029101	BUSH,NB-19
112	31239112	SCREW SET,W-SEMS M3*45 3CBC 50 PCS.
113	3000000547	SCREW,CUP P-TIGHT 3X6 NI
114	3000000548	SCREW,CUP P-TIGHT 3x8 3CBC

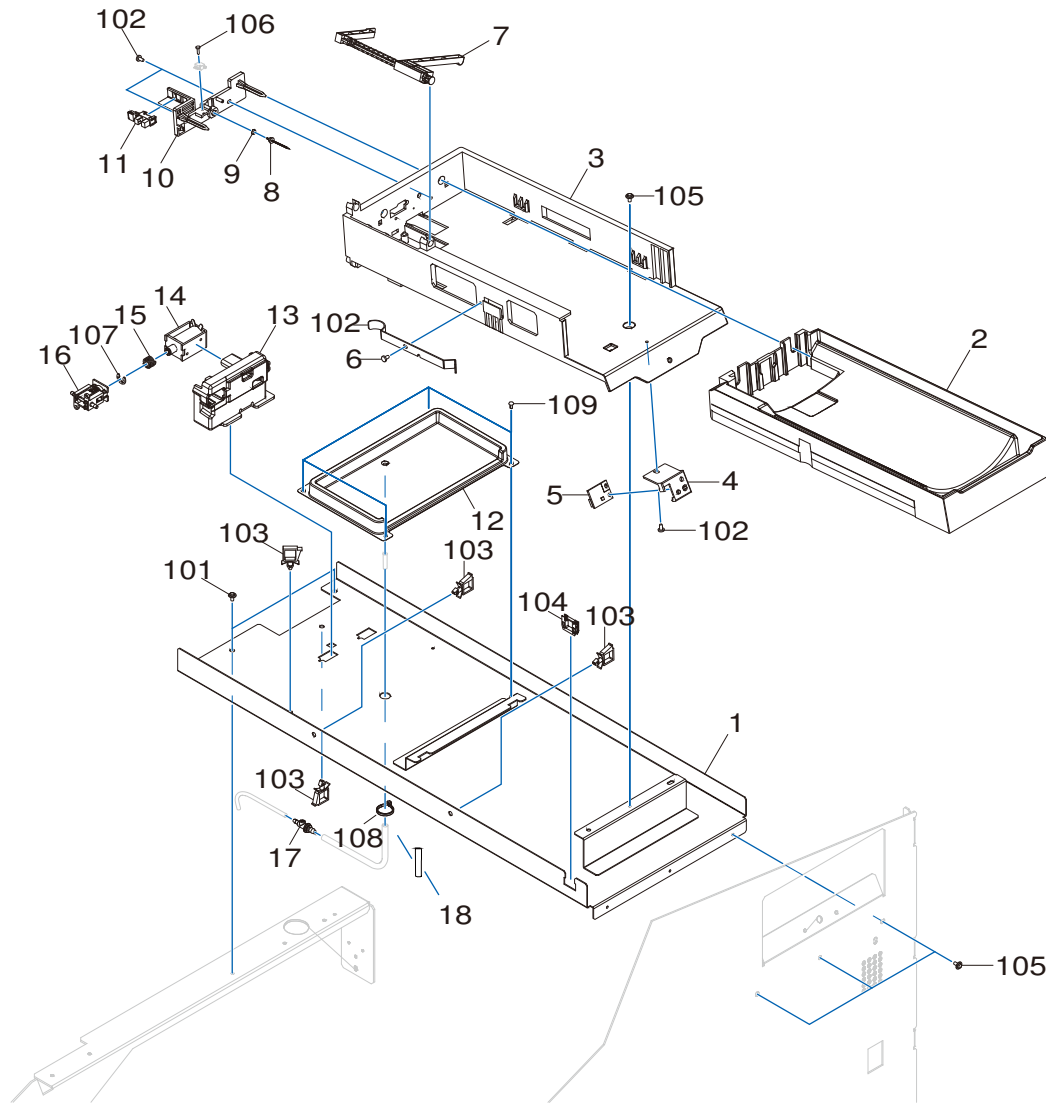

Pos	Code	Description
1	1000019755	BASE,CL CARTRIDGE CG2076
2	1000014586	TRAY, INK POUCHES VG-640
3	1000018348	FRAME,HOLDER I/C2 CG2023
4	1000017453	HOLDER,CARTRIDGE LED CG2023
5	1000017428	ASSY,CARTRIDGE LED BOARD CG2032
6	1000017438	SPRING,PLATE I/C CG2023
7	1000017437	LEVER,INK EMPTY CG2023
8	1000014443	NEEDLE,FAI1.2 VG-640
9	1000007988	RING,O 1.1*5.5
10	1000017435	HOLDER,NEEDLE I/C CG2023
11	1000011069	SENSOR-INTERRUPTER,OJ-535S-A5
12	1000019757	TRAY,CL CARTRIDGE CG2076
13	1000017442	HOLDER,CIRCULATION VALVE CG2023
14	1000018523	SOLENOID,TDS-08A DC-24V TYPE2
15	1000020061	SPRING,VALVE BIF-2TH
16	1000019097	VALVE,CHOKE CG2057
17	1000017901	ADAPTER,JOINT 3L CG2023
18	1000020264	PIPE,WR0640
101	31289102AS	CUPSCREW SET,M3*6 NI 50 PCS.
102	31019702AS	SCREW SET,BIND P-TIGHT M3*6 3C 100P
103	31409811AS	SADDLE SET,LOCKING WIRE LWS-1211Z 20P
104	31409702	SADDLE SET,LOCKING WIRE LES-1010 20P
105	31289105AS	CUPSCREW SET, M3*6 3CBC 100 PCS
106	3000000412	BIND,P-TIGHT 2*8 3C 20PCS.
107	31149704AS	RING SET,E-RING ETW-6 SUS 100 PCS
108	31329601AS	CLAMP SET,INSULOK T-18S 100 PCS.
109	31289105AS	CUPSCREW SET, M3*6 3CBC 100 PCS

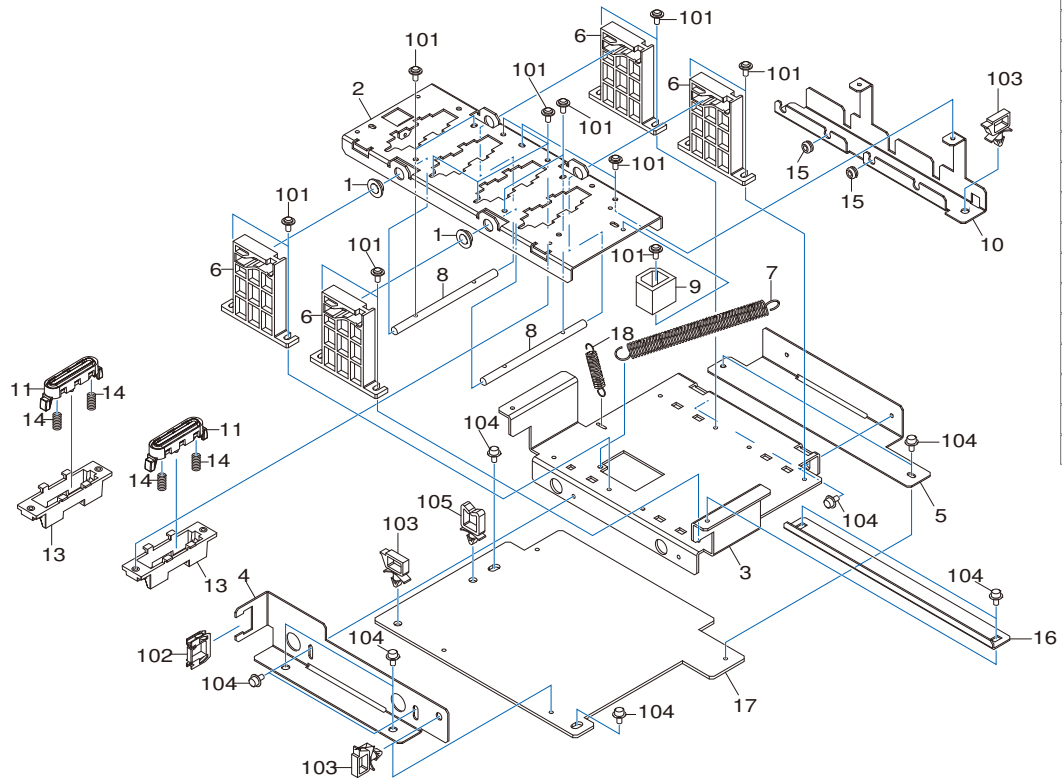

Pos	Code	Description
1	1000018512	BUSH,80F-0603
2	1000015458	FRAME,BACKUP CAP SG-540
3	1000015460	FRAME,BASE CAP SG-540
4	1000015461	STAY,ADJUSTER F CAP SG-540
5	1000015462	STAY,ADJUSTER R CAP SG-540
6	1000014455	GUIDE,SLIDE CAP VG-640
7	1000015456	SPRING,CAP SLIDE SG-540
8	1000015457	SHAFT,CAP LIFT SG-540
9	1000014468	STOPPER,ARM CAP VG-640
10	1000019699	STAY,TUBE CAP CG2076
11	6000004658	ASSY,CAP TOP SV CG2076
13	1000014760	HOLDER,CAP VG-640
14	1000015460	FRAME,BASE CAP SG-540
15	1000019700	GROMMET,RUBBER TM-346-13
16	1000020080	SUPPORT,GUIDE SLIDE CAP VG-640TH
17	1000020068	PLATE,CAP UNDER VG-640TH
18	1000015183	SPRING,CAP SWING VS-640
101	31289102AS	CUPSCREW SET,M3*6 NI 50 PCS.
102	31409702	SADDLE SET,LOCKING WIRE LES-1010 20P
103	3000000560	SADDLE,LOCKING WIRE LWS-0711Z_TH
104	31049154AS	SCREW SET,CAP M3*6 NI+PW 20 PCS
105	3000000216	SADDLE,WIRE WS-2N-V0

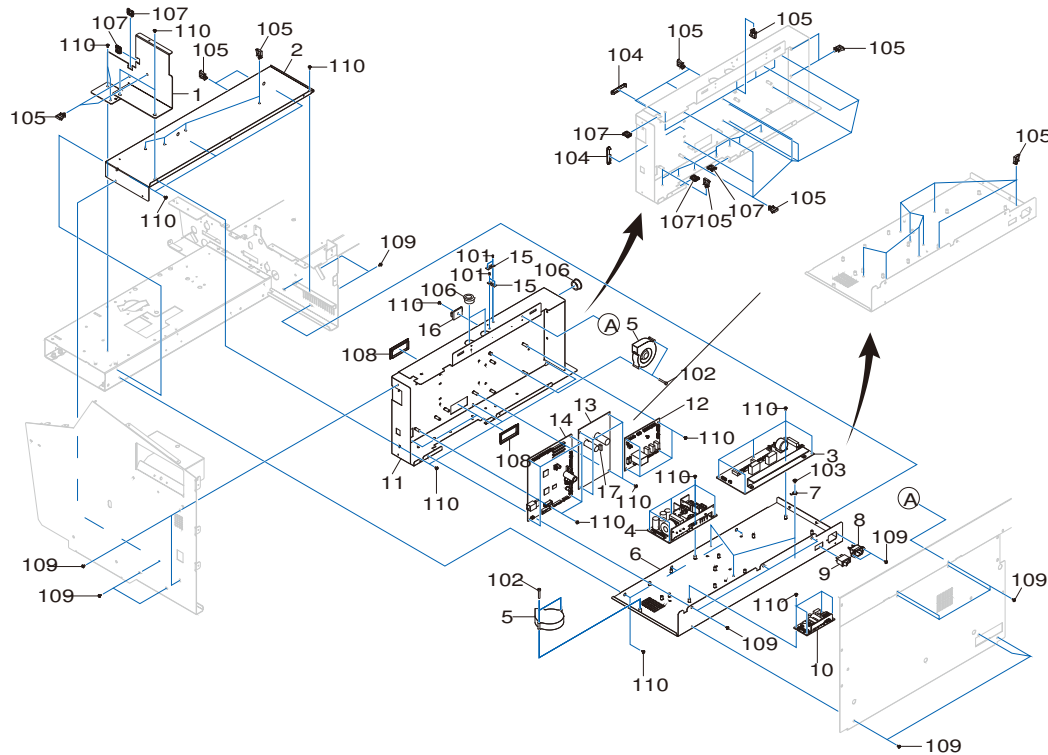

Pos	Code	Description
1	1000018779	STAY,SERVO BOARD CG2076
2	1000020260	STAY,CHASSIS COVER CG2076
3	1000018538	ASSY,HEATER CONTROL BOARD CG2075
4	1000014605	POWER UNIT,ZWS240BP-36/R(37)
5	1000018511	FAN,9BD24FA6-1+CN
6	1000019640	BASE,CHASSIS POWER CG2076
7	31329601AS	CLAMP SET,INSULOK T-18S 100 PCS.
8	13429702	INLET AC P01CF01 15A250V
9	1000018525	SW,POWER AJ8201BF
10	1000010042	POWER UNIT,ZWS30B-5
11	1000019643	BASE,CHASSIS BOARD CG2076
12	6000004233	ASSY,SIGNAL JUNCTION BOARD CG2075
13	6000005119	ASSY,FM3 SERVO BOARD CG2075_01
14	6000005189	ASSY,MAIN BOARD SV VG2-640
14	6000005218	ASSY,MAIN BOARD SV SG2-640
14	6000005504	ASSY,MAIN BOARD SV2 SG2-640
15	1000015428	PLATE,CABLE SLIT SG-540
16	1000015261	CLAMP,FCM1-S6
17	12559102	FUSE 11CT 3.15A
101	31299102AS	RIVET SET,NYLON P2655B 20 PCS.
102	3000000423	CAP-SCREW,4*25 3CBC 100PCS
102	31049137AS	SCREW SET,CAP M4*25 3CBC 20 PCS
103	31289111AS	CUPSCREW SET, M4*6 NI 100 PCS.
104	3000000033	CLAMP,WIRE PLESS RFC-45VO
105	31409811AS	SADDLE SET,LOCKING WIRE LWS-1211Z 20P
106	31029101	BUSH,NB-19
107	31409702	SADDLE SET,LOCKING WIRE LES-1010 20P
108	31029106	BUSH,SQUARE SB-6025
109	31289105AS	CUPSCREW SET, M3*6 3CBC 100 PCS
110	31289102AS	CUPSCREW SET,M3*6 NI 50 PCS.

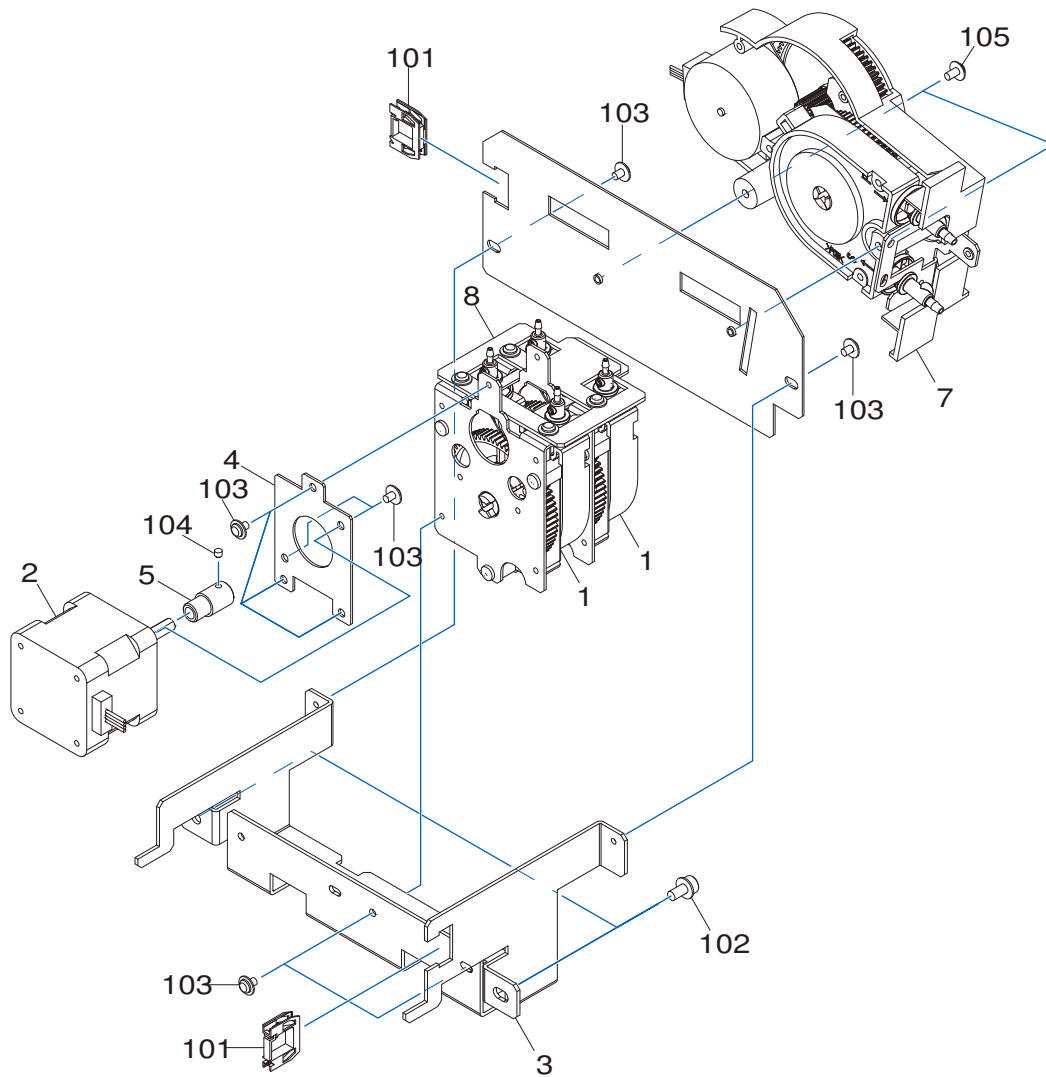

Pos	Code	Description
1	6000004717	ASSY,PUMP SUB SV CG2076
2	1000018514	MOTOR,103-5208-85542
3	1000019751	STAY,PUMP CG2076
4	1000020054	PLATE,P-MOTOR XC-540TH
5	1000012988	GEAR,S10B20
6	1000019752	STAY,WIPER PUMP CG2076
7	6000005252	ASSY,PRESS PUMP SV2 CG2076
8	1000021377	PLATE,PUMP JOINT 2 CG2075
101	31409702	SADDLE SET,LOCKING WIRE LES-1010 20P
102	3000000172	SCREW SET,CAP M4*8 NI WSH4*9*0.8 20P
103	31289109AS	CUPSCREW SET,M3*4 NI 100 PCS
104	31199701AS	SCREW SET,SET WP M3*3 NI 20 PCS
105	31089117	SCREW SET,PAN 3*6 NI+PW 100 PCS.

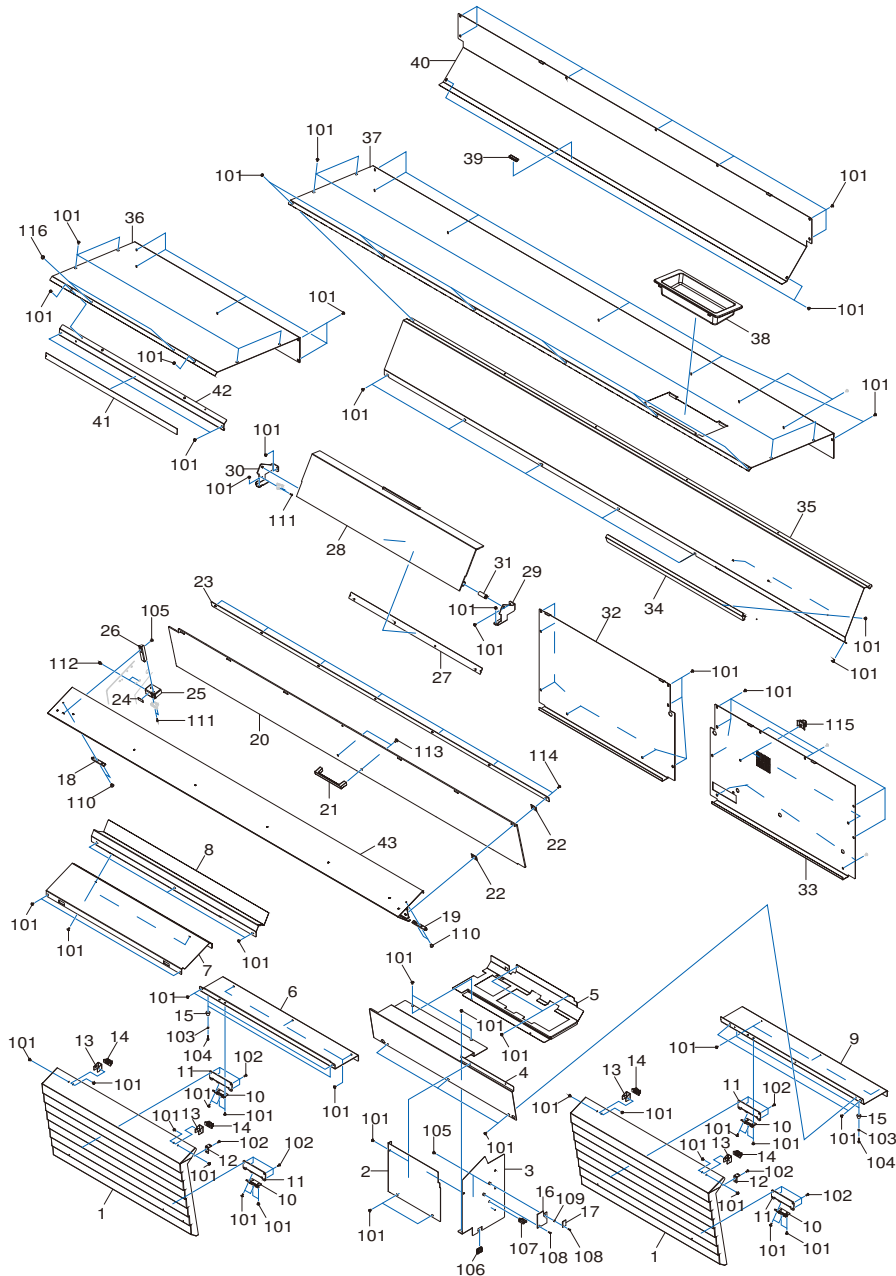

Pos	Code	Description
1	1000020102	COVER,SIDE CG2076
2	1000019412	COVER,PANEL UNDER 2 SG-540
3	1000019686	COVER,FEED MOTOR CG2076
4	1000019711	COVER,MAINTENANCE F CG2076
5	1000019642	COVER,MAINTENANCE CG2076
6	1000015402	COVER,UNDER L SG-540
7	1000021149	PLATE,COVER L CG2092
8	1000015401	COVER,INK PANEL UNDER SG-540
9	1000015415	COVER,UNDER R SG-540
10	1000018506	HINGE,BP-151-1
11	1000015406	STAY,COVER SG-540
12	1000015417	STAY,COVER M SW SG-540
13	1000019406	STAY,COVER CATCH 2 SG-540
14	1000019423	MAGNET,SM-133
15	11879107	ABSORBER TK-12
16	1000015537	ASSY,BLE JUNCTION BOARD SG-540
17	1000014067	BLE-MODULE,LBCA2ZZVZE-722
18	1000019687	SHAFT,COVER CG2076
19	1000019720	SHAFT,COVER FRONT R CG2076
20	1000019731	PLATE,FRONT COVER CG2075
21	1000014578	KNOB,A-165-4
22	21425110	WASHER,COVER FJ-50
23	1000019735	STAY,COVER FRONT CG2075
24	1000017768	PAD,FRONT COVER CG2023
25	1000019690	STAY,COVER INT CG2076
26	1000019689	HOOK,INT SW CG2076
27	1000014822	LABEL,EMPTY LAMP VG-640#LA2169
28	1000014364	COVER,INK CARTRIDGE VG-640
29	1000017358	HINGE,COVER INK R CG2032
30	1000020771	HINGE,COVER INK L CG2092
31	1000014485	DAMPER,TD75 B1-1K
32	1000019685	COVER,BACK L CG2076
33	1000019682	COVER,CHASSIS CG2076
34	1000015418	DOCK,TABLET PC SG-540
35	1000020775	PLATE,COVER F CG2092
36	1000020773	COVER,TOP L CG2092
37	1000020774	COVER,TOP R CG2092
38	1000017762	TRAY,TOOL CG2023
39	1000015160	GASKET,STGH 5-8 L=30MM
40	1000019734	COVER,RAIL CG2075

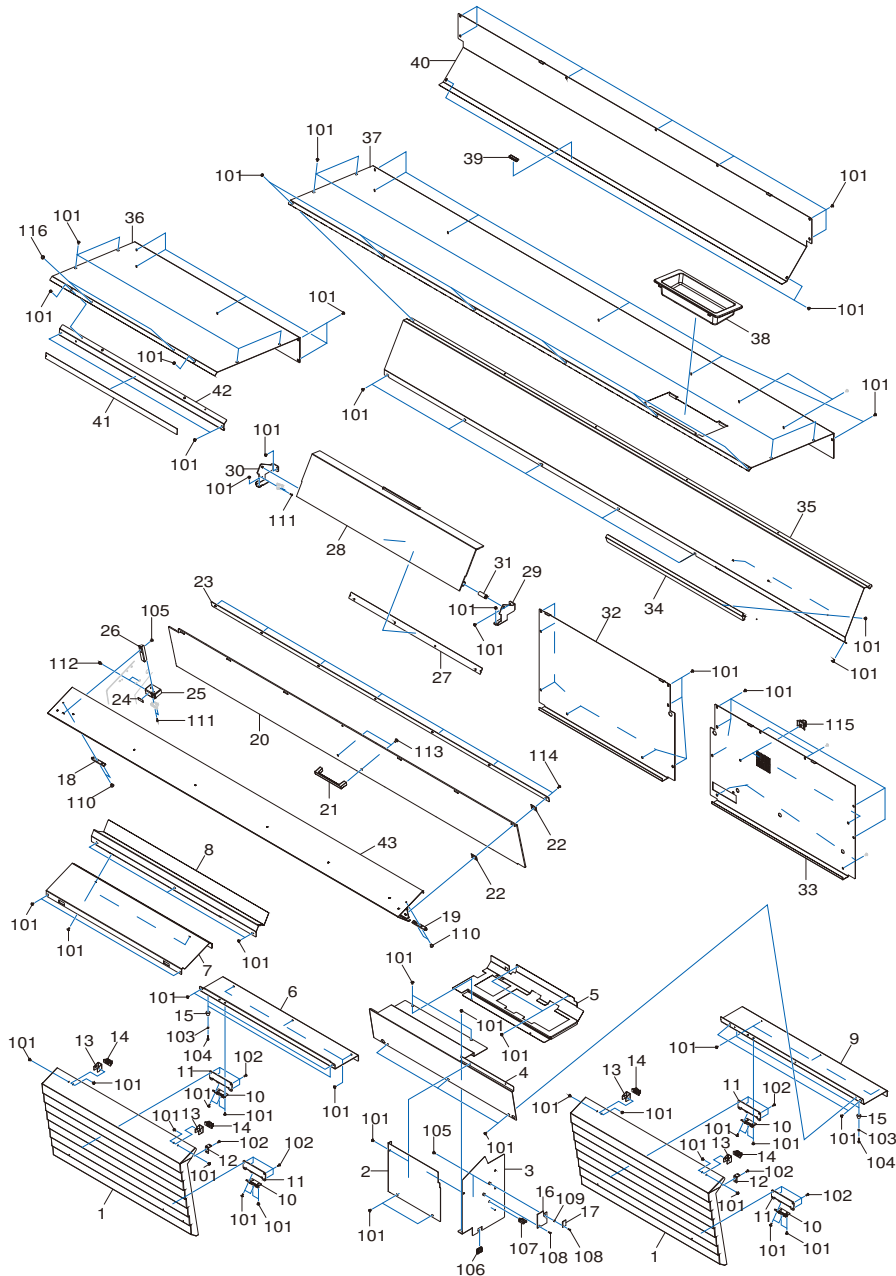

Pos	Code	Description
41	1000018948	LABEL, SET INK SG-540#LA3239
42	1000020772	COVER,INK PANEL CG2092
43	1000021147	COVER,FRONT CG2092
101	31289105AS	CUPSCREW SET, M3*6 3CBC 100 PCS
102	31019703	SCREW,BINDING P-TIGHT M3*8 3C 100P
103	31029802AS	BUSH SET,ROLL 3*3.5 3C 100PCS.
104	31049171AS	SCREW SET,CAP M3*12 NI 50 PCS.
105	31289102AS	CUPSCREW SET,M3*6 NI 50 PCS.
106	31409702	SADDLE SET,LOCKING WIRE LES-1010 20P
107	3000000216	SADDLE,WIRE WS-2N-V0
108	3000000431	NABE,2.5*8 NI 20PCS.
109	31029820	BUSH SET,ROLL 3*2 3C 50PCS
110	31289110AS	CUPSCREW SET, M4*8 3CBC 100 PCS
111	31019149	SCREW SET,BINDING M2.3*8 3CBC 100PCS
112	3000000430	CAP-SCREW,4*6 NI
112	31799107	SCREW SET,CAP M4*6 NI 20PCS
113	3000000500	BIND,5*8 NI
114	3000000200	SCREW SET,CUP 3*8 NI MEKKU 20PCS
115	31379111	CLAMP,CABLE CKS-13-H
116	12239406	CUSHION,TM-96-6

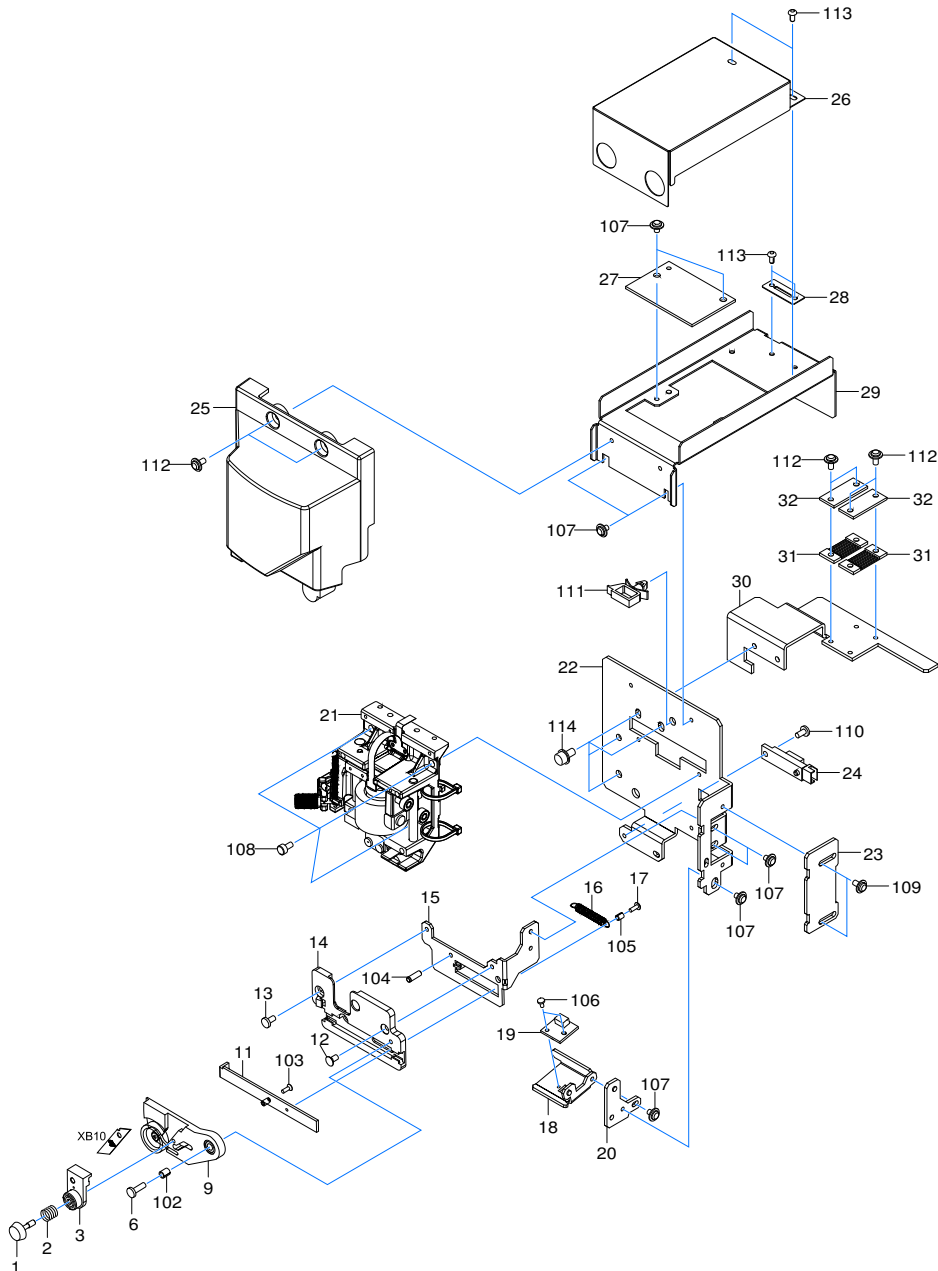

Pos	Code	Description
1	21495115	SCREW,BLADE SET CM-500
2	1000012948	SPRING,SCREW CM-500
3	W021765110	CLAMP,BLADE CM-500
6	31019118AS	SCREW SET,BINDING M3*10 3CBC 100PCS
9	22805291	ASSY,HOLDER BLADE SV CM-500
11	22805287	ASSY,PLATE CAM SLIDE SV CM-500
12	31169103AS	SCREW SET,FLAT M3*6 3CBC 100 PCS
13	31019116AS	SCREW SET,BINDING M3*6 3CBC 100 PCS
14	6000004729	BASE,CUTTER CG2076
15	1000020661	FRAME,CUTTER 2 CG2076
16	1000012947	SPRING,BLADE UP CM-500
17	31229103AS	SCREW SET,TRUSS M2*6 NI 100 PCS
18	1000019641	STAY,CROP SENSOR CG2076
19	6000004234	ASSY,CROP SENSOR BOARD CG2075
20	1000021701	PLATE,CUT CARRIAGE2 CG2076
21	6000004664	ASSY,CUT TOOL T CG2076_01
22	1000020660	FRAME,CUT CARRIAGE 2 CG2076
23	1000018764	PLATE,ADJUSTER MAGNET CG2076
24	15099115	SENSOR-INTERRUPTER GP2A25NJ
25	1000020806	COVER,CUT CARRIAGE CG2076
25	1000021701	PLATE,CUT CARRIAGE2 CG2076
26	1000019650	COVER,CUT BOARD CG2076
27	W704890120	ASSY,CUT CARRIAGE CG2075_01
28	1000015428	PLATE,CABLE SLIT SG-540
29	1000019708	STAY,CUT CARRIAGE BOARD CG2076
30	1000015486	STAY,HOLDER BELT SG-540
31	1000015114	HOLDER,BELT EGX-600_01
32	1000020055	COVER,BELT HOLDER EGX-600TH
102	31029803AS	BUSH SET,ROLL 3*5 3C 20PCS.
103	31169111	SCREW SET,FLAT M2*6 NI 100 PCS.
104	3000000617	SET-SCREW,FP 3*10 3C MEKKU
105	31029801AS	BUSH SET,ROLL 2*4 3C100PCS
106	31019169	SCREW SET,BINDING M2*4 NI 100 PCS.
107	31289109AS	CUPSCREW SET,M3*4 NI 100 PCS
108	31049105AS	SCREW SET,CAP M3*6 3CBC 20 PCS
109	31089117	SCREW SET,PAN 3*6 NI+PW 100 PCS.
110	31019116AS	SCREW SET,BINDING M3*6 3CBC 100 PCS
111	31409801AS	SADDLE,LOCKING WIRE LWS-0711Z 20P
112	31289102AS	CUPSCREW SET,M3*6 NI 50 PCS.
113	31299102AS	RIVET SET,NYLON P2655B 20 PCS.

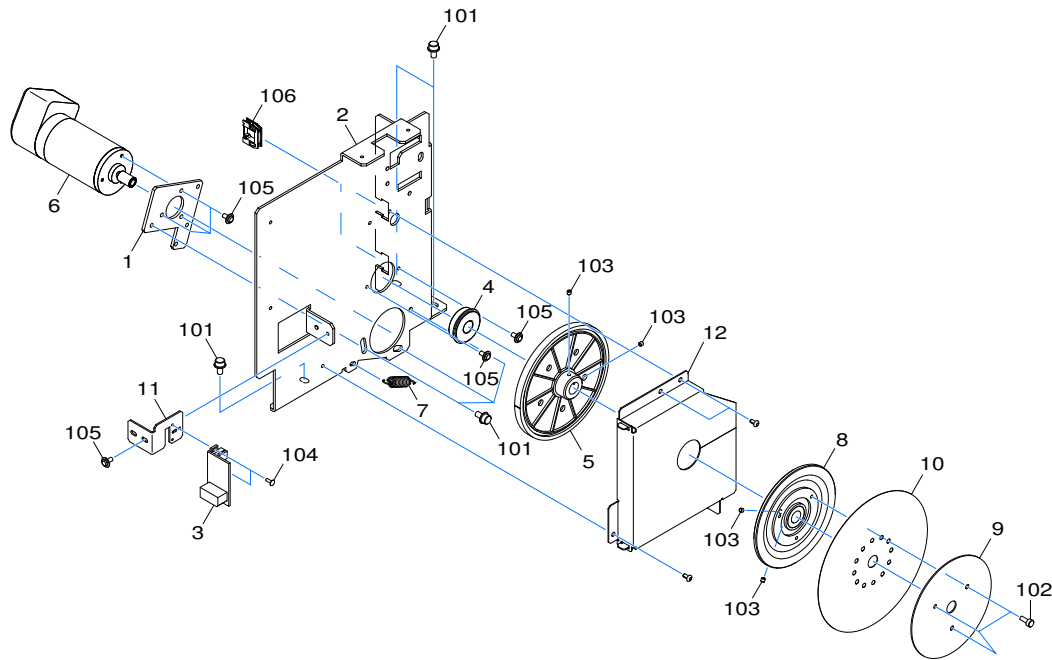

Pos	Code	Description
1	1000014906	FLANGE,MOTOR FEED VS-640I
2	1000019709	STAY,SUPPORT RAIL R CG2076
3	W704890130	ASSY,GRIT ENCODER CG2075_01
4	1000006709	R-BEARING,6000ZZNR*NS7S
5	21685128	GEAR H300 S10(B6C16POM)
6	6000002592	ASSY,FEED MOTOR VS-640_01
7	22175157	SPRING,C P-ROLLER CM-500
8	1000002593	FLANGE,GRIT-ENCORDER VP-540
9	1000015595	STOPPER,GRIT-ENCORDER VP-540
10	1000015584	SHEET,ROTARY DISK SLIT 360LPI
11	1000014904	STAY,G-ENCODER SENSOR VP-540
12	1000014121	COVER,FEED GEAR RE-640
101	3000000172	SCREW SET,CAP M4*8 NI WSH4*9*0.8 20P
102	31049170AS	SCREW SET,CAP M3*8 NI 50 PCS.
103	31199701AS	SCREW SET,SET WP M3*3 NI 20 PCS
104	31229103AS	SCREW SET,TRUSS M2*6 NI 100 PCS
105	31289102AS	CUPSCREW SET,M3*6 NI 50 PCS.
106	31409702	SADDLE SET,LOCKING WIRE LES-1010 20P

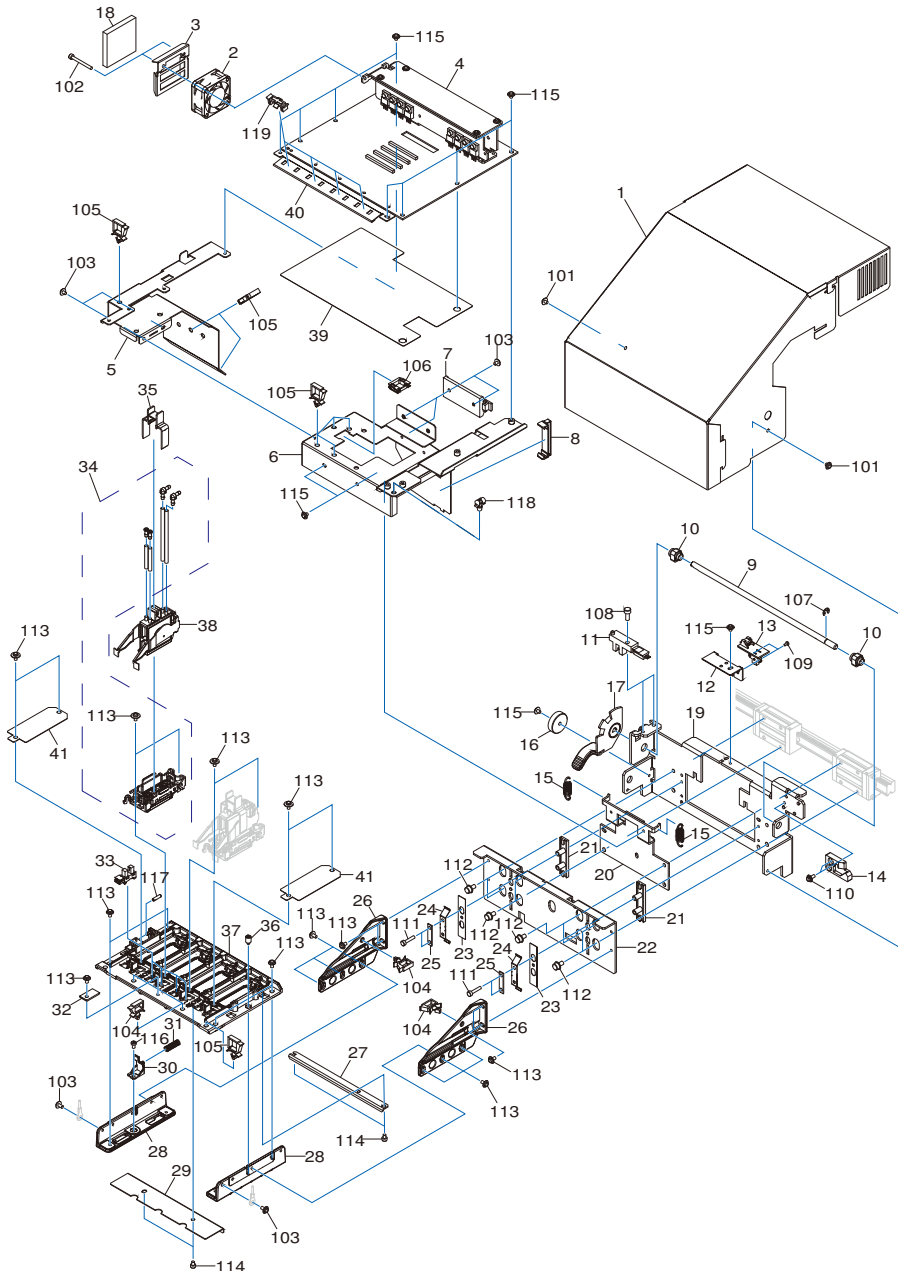

Pos	Code	Description
1	1000020028	COVER,PRINT CARRIAGE CG2076
2	1000018524	FAN,109P0424H642_80
3	1000019713	STAY,CARRIAGE FILTER CG2076
4	6000004973	ASSY,PRINT CARRIAGE BOARD CG2092_00
5	1000019636	STAY,CARRIAGE TUBE CG2076
6	1000019710	STAY,HOLDER CARRIAGE B CG2076
7	11769118	CLAMP,FCM2-S6-14
8	1000015378	GUIDE,TUBE SG-540
9	1000019637	SHAFT,CARRIAGE CG2076
10	1000019707	CAM,CARRIAGE CG2076
11	1000006689	SENSOR-INTERRUPTER,EE-SX4009-P1
12	1000015477	PLATE,ENC SENS SG-540
13	1000015533	ASSY,LINEAR ENCODER BOARD SG-540
14	21345105	LOCK,CJ-500
15	1000020071	SPRING,PULL CARRIAGE 5700 VG-640TH
16	1000011928	MAGNET,SMF-2144
17	1000019638	LEVER,CARRIAGE CG2076
18	1000019714	FILTER,CARRIAGE CG2076
19	1000020800	BASE,HOLDER CARRIAGE CG2076_TH
19	1000022213	BASE,HOLDER CARRIAGE2 CG2076_TH
20	1000020070	SUPPORT,CARRIAGE BOARD EJ-640TH
21	1000015113	SLIDER,CARRIAGE FJ-540_02
22	1000020069	FRAME,CARRIAGE U/D VG-640TH
23	1000020067	PLATE,SLIDER CARRIAGE FJ-540TH
24	1000014902	SPRING,CARRIAGE SIDE FJ-50
25	1000020066	SPACER,CARRIAGE SLIDE XF-640TH
26	1000014771	BASE,CARRIAGE SIDE ADC VG-640
27	1000016913	COVER,IJ HEAD REAR VG-640
28	1000014773	STAY,CARRIAGE ADC VG-640
29	1000019102	COVER,CARRIAGE MIST VG-640_02
30	1000014774	BLOCK,ADJUST CARRIAGE VG-640
31	1000014902	SPRING,CARRIAGE SIDE FJ-50
32	1000015534	ASSY,THERMISTOR BOARD SG-540
33	1000011069	SENSOR-INTERRUPTER,OJ-535S-A5
34	6000004770	ASSY,IJ HEAD SOL 250L SV CG2076
35	1000015045	GUARD,FFC HEAD VG-640
36	1000015479	PIN,PIVOT SCREW SG-540
37	1000018832	BASE,CARRIAGE ADC VG-640_02
38	1000019701	ASSY,DAMPER DOUBLE CIR CG2075
39	1000020736	COVER,CARRIAGE BOARD UNDER2 CG2076

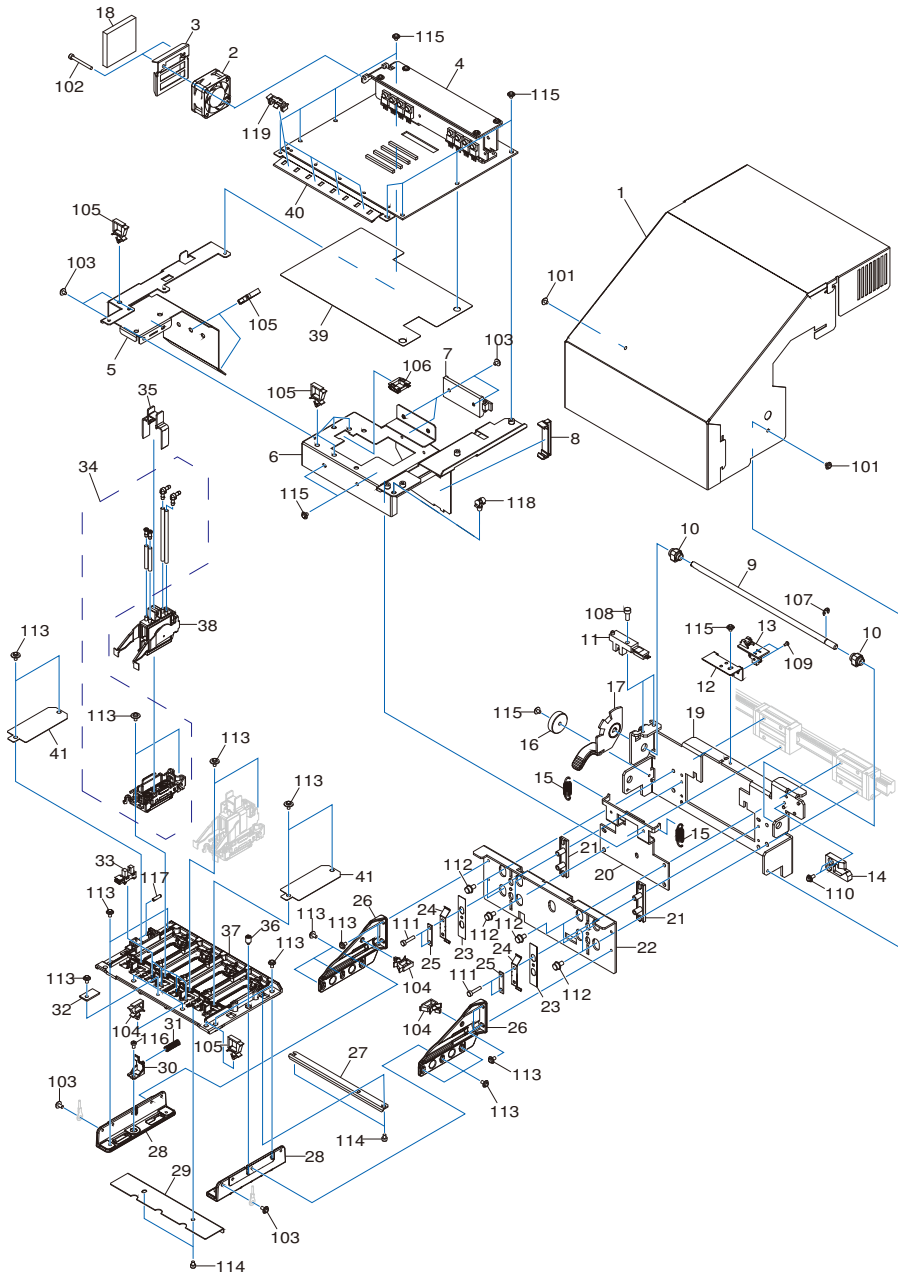

Pos	Code	Description
40	1000019712	STAY,HEAD FFC CG2076
41	1000015478	SHEET,HEAD COVER SG-540
101	31089110AS	SCREW SET,PAN M3*4 NI+PW 100 PCS
102	3000000465	CAP-SCREW,3*30 NI 100PCS
103	31289102AS	CUPSCREW SET,M3*6 NI 50 PCS.
104	3000000560	SADDLE,LOCKING WIRE LWS-0711Z_TH
105	31409811AS	SADDLE SET,LOCKING WIRE LWS-1211Z 20P
106	31409702	SADDLE SET,LOCKING WIRE LES-1010 20P
107	3000000557	RING,E ETW-ES4 3C_TH
108	3000000426	CAP-SCREW,4*10 NI 100PCS
109	31019169	SCREW SET,BINDING M2*4 NI 100 PCS.
110	3000000429	W-SEMS,3*8 SUS 100PCS
111	3000000462	CAP-SCREW,3*15 NI 100PCS
112	3000000172	SCREW SET,CAP M4*8 NI WSH4*9*0.8 20P
113	31089117	SCREW SET,PAN 3*6 NI+PW 100 PCS.
114	31049119	SCREW SET,CAP M3*4 NI 20PCS.
115	31289109AS	CUPSCREW SET,M3*4 NI 100 PCS
116	3000000414	LH-SCREW,CSHBTT-SUS-M3-5 20PCS
117	3000000413	SET-SCREW,MARUSAKI_3_12_NI 20PCS
118	31329501AS	CLAMP SET,PUSH MOUNT RT30SSF5 20P
119	3000000549	CLAMP,WIRE PRESS RFC-16V0

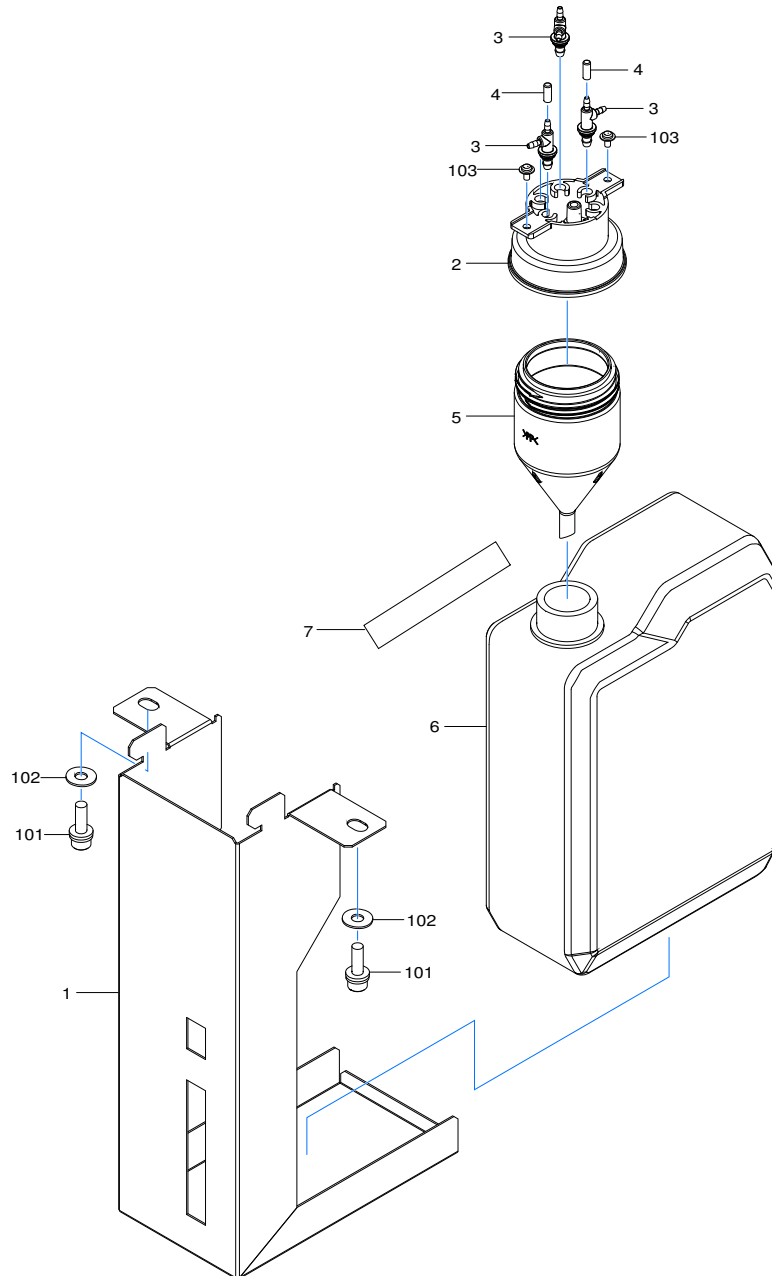

Pos	Code	Description
1	1000020945	HOLDER,BOTTLE INK2 CG2076
2	1000019746	CAP,PP BOTTLE CG2075
3	1000001577	ADAPTER,TUBE 2-4-T XC-540
4	1000002019	STOPPER,PUMP XC-540
5	1000019739	GUIDE,INK FUNNEL CG2075
6	11369122	CASE,PE BOTTLE 5-038-03
7	1000021531	LABEL,GUIDE DRAIN BOTTLE#LA3662
101	31049157	SCREW,CAP M6*20 3CBC+PW+SW
102	31249220AS	WASHER SET,PLAIN 6.5*16*1 NI 100PCS
103	31089117	SCREW SET,PAN 3*6 NI+PW 100 PCS.

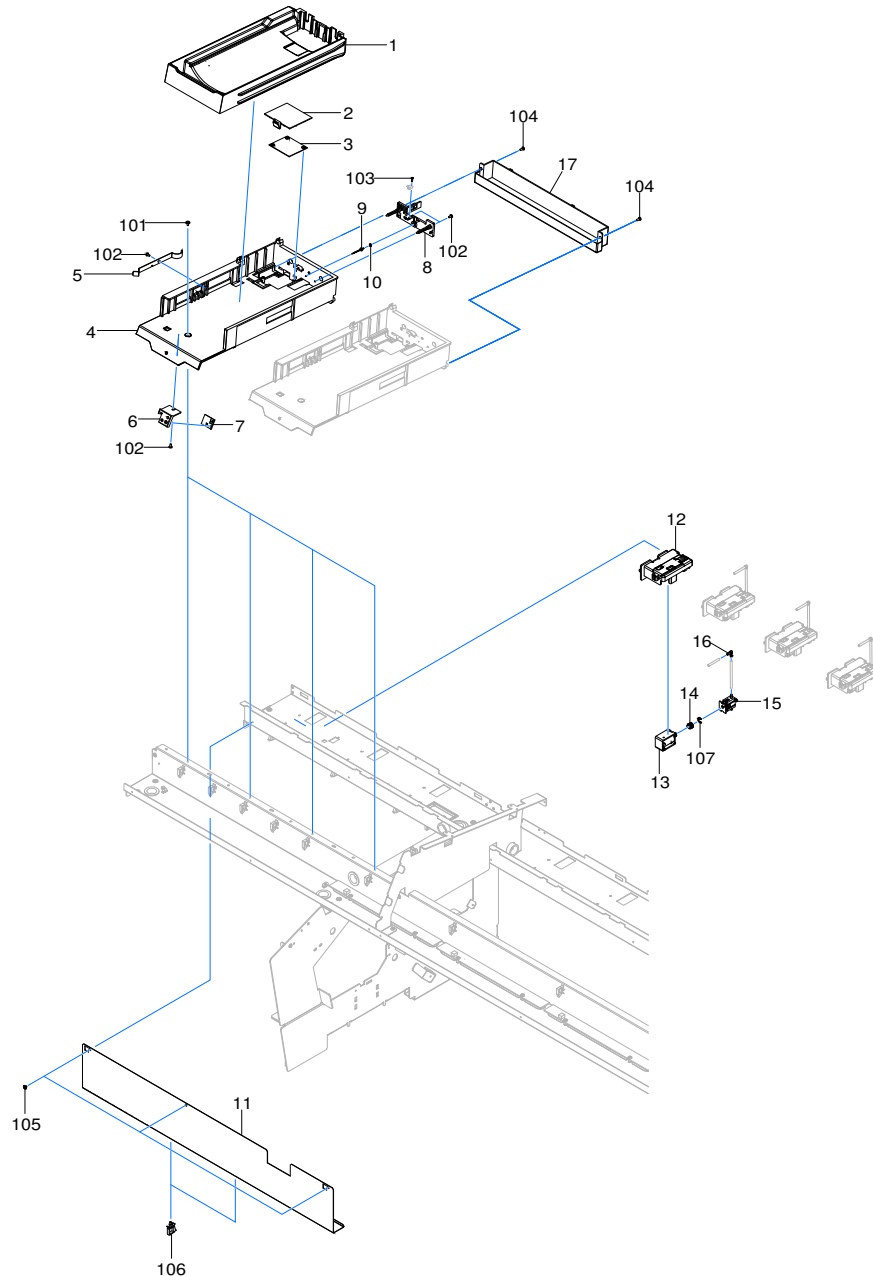

Pos	Code	Description
1	1000014586	TRAY, INK POUCHES VG-640
2	1000017439	COVER,RFID I/C CG2023
3	1000014128	RFID-MODULE,LXRFZZHAAA-022
4	1000018348	FRAME,HOLDER I/C2 CG2023
5	1000017438	SPRING,PLATE I/C CG2023
6	1000017453	HOLDER,CARTRIDGE LED CG2023
7	1000017428	ASSY,CARTRIDGE LED BOARD CG2032
8	1000017435	HOLDER,NEEDLE I/C CG2023
9	1000014443	NEEDLE,FAI1.2 VG-640
10	1000007988	RING,O 1.1*5.5
11	1000020768	COVER,INK TUBE ROUTE CG2092
12	1000017442	HOLDER,CIRCULATION VALVE CG2023
13	1000018523	SOLENOID,TDS-08A DC-24V TYPE2
14	1000020061	SPRING,VALVE BIF-2TH
15	1000019097	VALVE,CHOKE CG2057
16	1000017901	ADAPTER,JOINT 3L CG2023
17	1000017443	TRAY,INK HOLDER CG2023
101	31289105AS	CUPSCREW SET, M3*6 3CBC 100 PCS
102	31019702AS	SCREW SET,BIND P-TIGHT M3*6 3C 100P
103	3000000412	BIND,P-TIGHT 2*8 3C 20PCS.
104	31019703	SCREW,BINDING P-TIGHT M3*8 3C 100P
105	31289109AS	CUPSCREW SET,M3*4 NI 100 PCS
106	31409811AS	SADDLE SET,LOCKING WIRE LWS-1211Z 20P

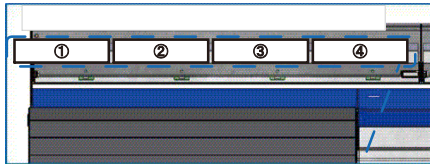

Pos	Code	Description
1	1000017901	ADAPTER,JOINT 3L CG2023
2	1000017466	TUBE,PT05-RDG 3X3.8 LINK4 SG-540 TH
3	1000017900	PLUG,STOPPER FAI3 CG2023
4	3000000489	TUBE,PT05-RDG 3X3.8 100M

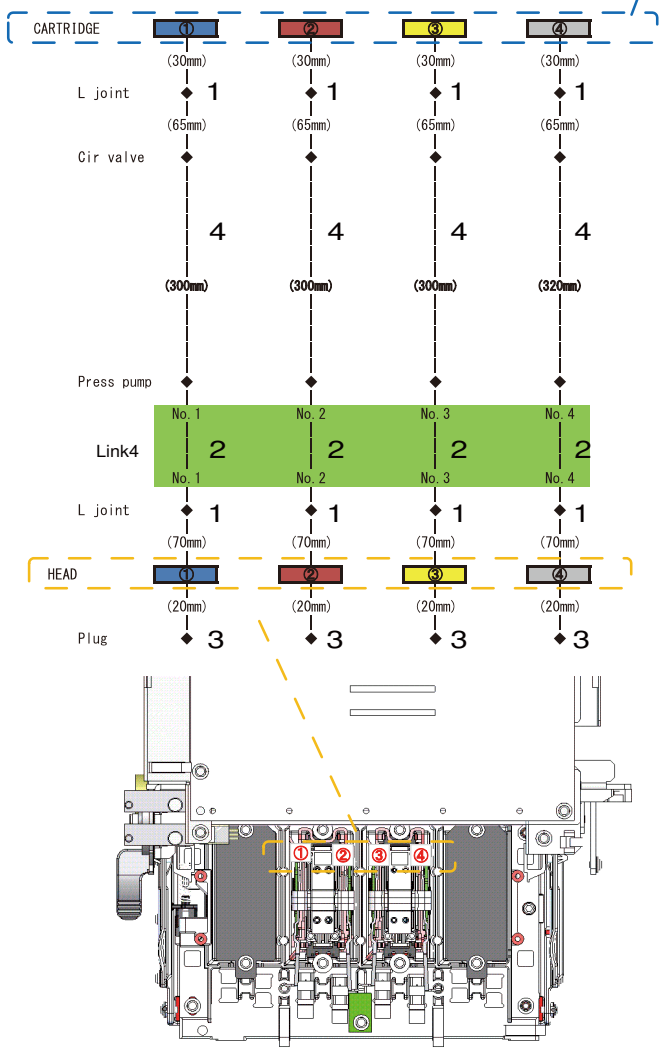

Pos	Code	Description
1	3000000489	TUBE,PT05-RDG 3X3.8 100M
2	3000000551	TUBE,IIR 1.8-3.8 100M
3	3000000422	TUBE,TM-15 6*8 50M
4	1000017828	ADAPTER,JUNCTION MCS3060
5	1000001577	ADAPTER,TUBE 2-4-T XC-540
6	1000002019	STOPPER,PUMP XC-540
7	3000000176	TUBE,TM-50BKR 4*6 50M
8	1000015119	ADAPTER,TUBE 3-4 LEC-330_01
9	1000020264	PIPE,WR0640
10	31329601AS	CLAMP SET,INSULOK T-18S 100 PCS.

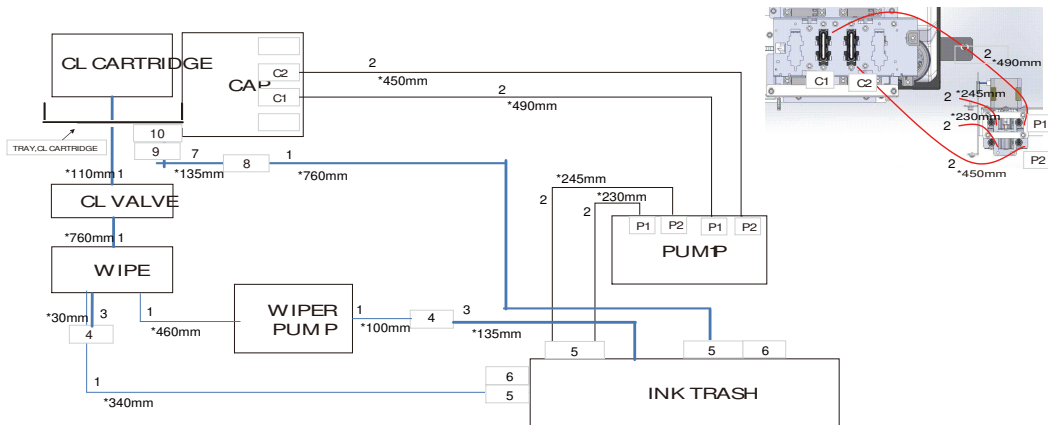

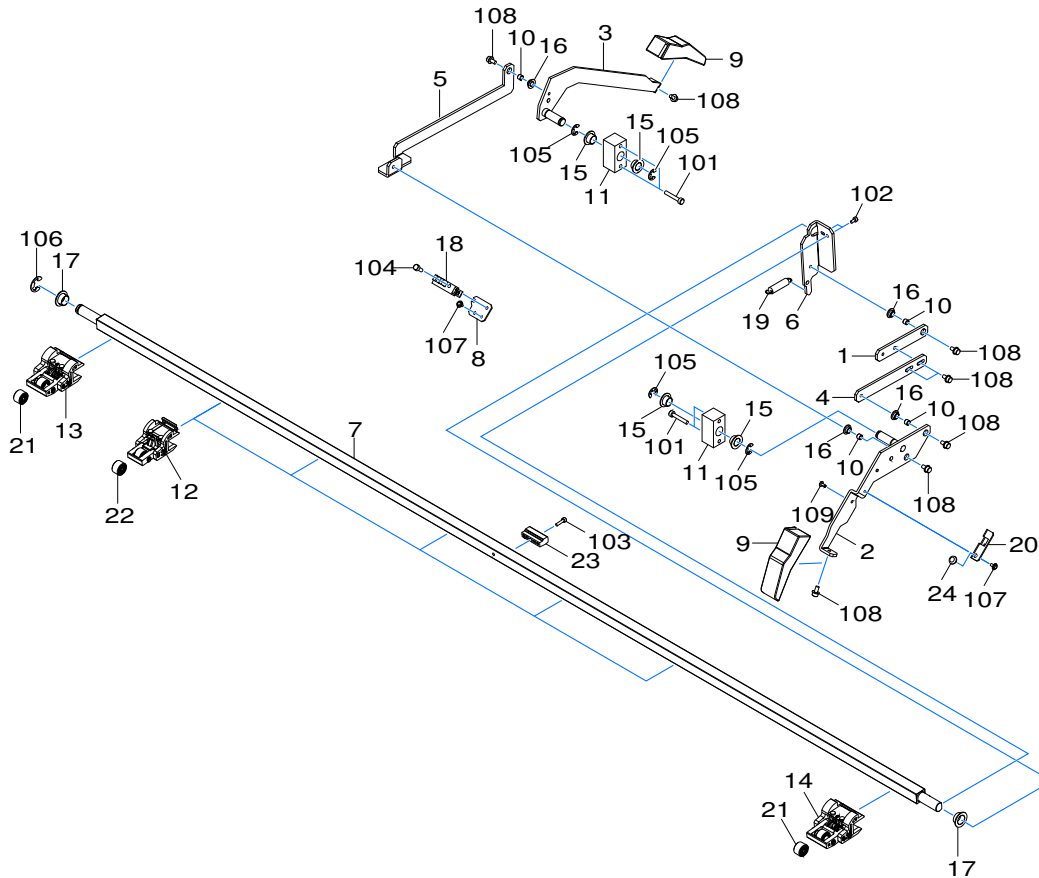

Pos	Code	Description
1	1000015384	STAY,LEVER ADJ SG-540
2	1000019046	LEVER,CAM PINCH FRONT CG2076 TH
3	1000016837	LEVER,CAM PINCH REAR SG-540_01
4	1000019032	STAY,LINK FRONT SG-540_03
5	1000015388	STAY,LINK REAR SG-540
6	1000020259	PLATE,LINK SUPPORT CG2076
7	1000018801	SHAFT,SQUARE CG2075
8	1000015390	STAY,PINCH SENS SG-540
9	1000014431	KNOB,VG-640
10	1000012953	COLLAR,LEVER FJ-540
11	22035196	STAND,LEVER SP-300
12	6000003918	ASSY,PINCHROLL C CG2023
13	6000005216	ASSY,PINCHROLL L CG2076_TH
14	6000005217	ASSY,PINCHROLL R CG2076_TH
15	1000018503	BUSH,80F-1006
16	1000018512	BUSH,80F-0603
17	1000018504	BUSH,SHAFT OILES 80F-1206
18	1000006689	SENSOR-INTERRUPTER,EE-SX4009-P1
19	1000012989	SPRING,PINCH PNC-1850
20	1000018791	STAY,LEVER CUSHION CG2076
21	6000003824	ASSY,P-ROLLER TD16S4(B10) TYPE 2_01
22	6000003823	ASSY,P-ROLLER FD16S4(B10) TYPE 2_01
23	1000018591	STOPPER,SHAFT SQUARE CG2023
24	12239406	CUSHION,TM-96-6
101	3000000423	CAP-SCREW,4*25 3CBC 100PCS
102	31049142AS	SCREW SET,CAP M3*6 NI MEC 20 PCS
103	31049171AS	SCREW SET,CAP M3*12 NI 50 PCS.
104	31049173AS	SCREW SET,CAP M4*10 NI 50 PCS.
105	31149705	RING SET,E-RING ETW-7 SUS 50PCS
106	31149706AS	RING SET,E-RING ETW-10 SUS 20 PCS
107	31289102AS	CUPSCREW SET,M3*6 NI 50 PCS.
108	3000000172	SCREW SET,CAP M4*8 NI WSH4*9*0.8 20P
109	31159904	RIVET SET,NYLON P3065B 20 PCS.

Pos	Code	Description
1	1000020776	COVER,PANEL CG2092
2	1000015421	SHEET,PANEL SG-540
3	1000020096	KEY, TOP BLUE CG2076
4	6000004230	ASSY,PANEL BOARD CG2075
5	1000012564	KEY, TOP CLEAR GS-24
101	31289102AS	CUPSCREW SET, M3*6 NI 50 PCS.
102	31289105AS	CUPSCREW SET, M3*6 3CBC 100 PCS

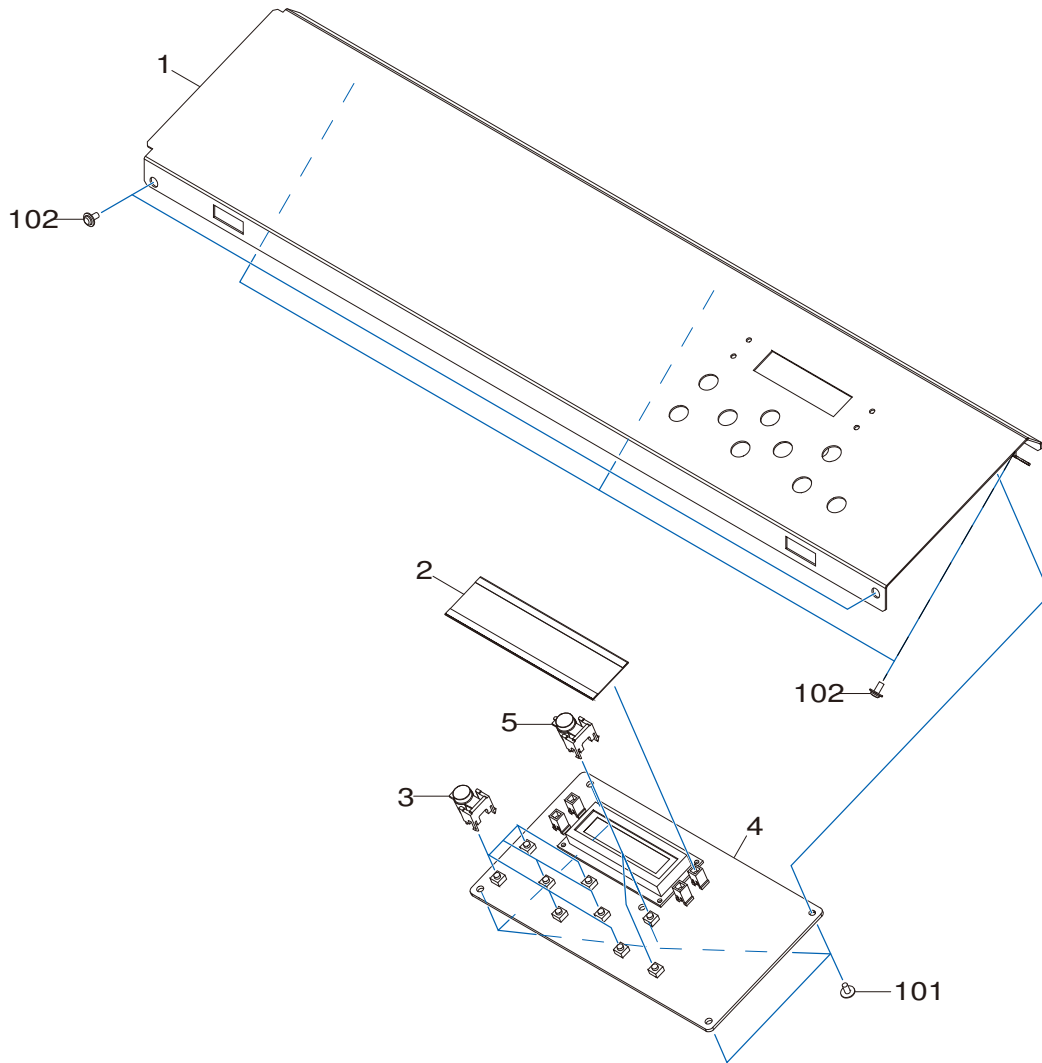

Pos	Code	Description
1	1000019754	PLATE,UNDER L CG2076
2	1000019753	STAY,INKSYSTEM BOARD CG2076
3	31029106	BUSH,SQUARE SB-6025
4	6000005252	ASSY,PRESS PUMP SV2 CG2076
5	1000017440	HOLDER, PRESS PUMP CG2023
6	6000004975	ASSY,INKSYSTEM RFID BOARD CG2092_00
7	6000004974	ASSY,EX MTR 9CH BOARD CG2092_00
101	3000000216	SADDLE,WIRE WS-2N-V0
102	31289102AS	CUPSCREW SET,M3*6 NI 50 PCS.
103	31289109AS	CUPSCREW SET,M3*4 NI 100 PCS

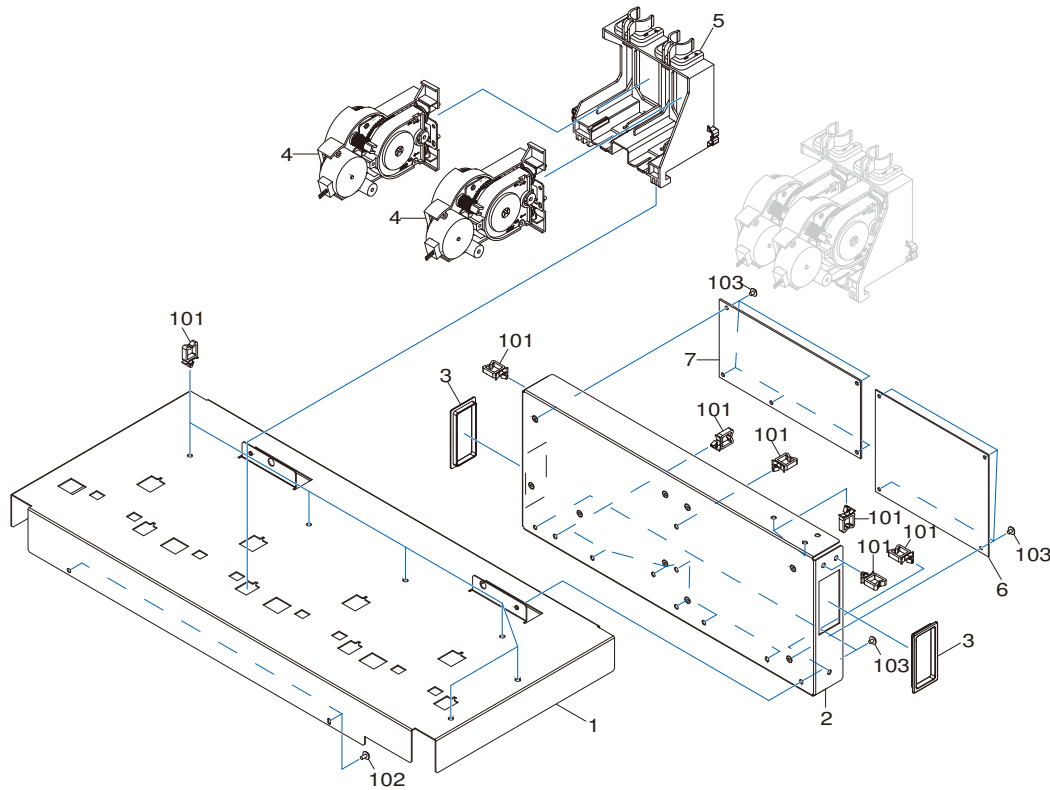

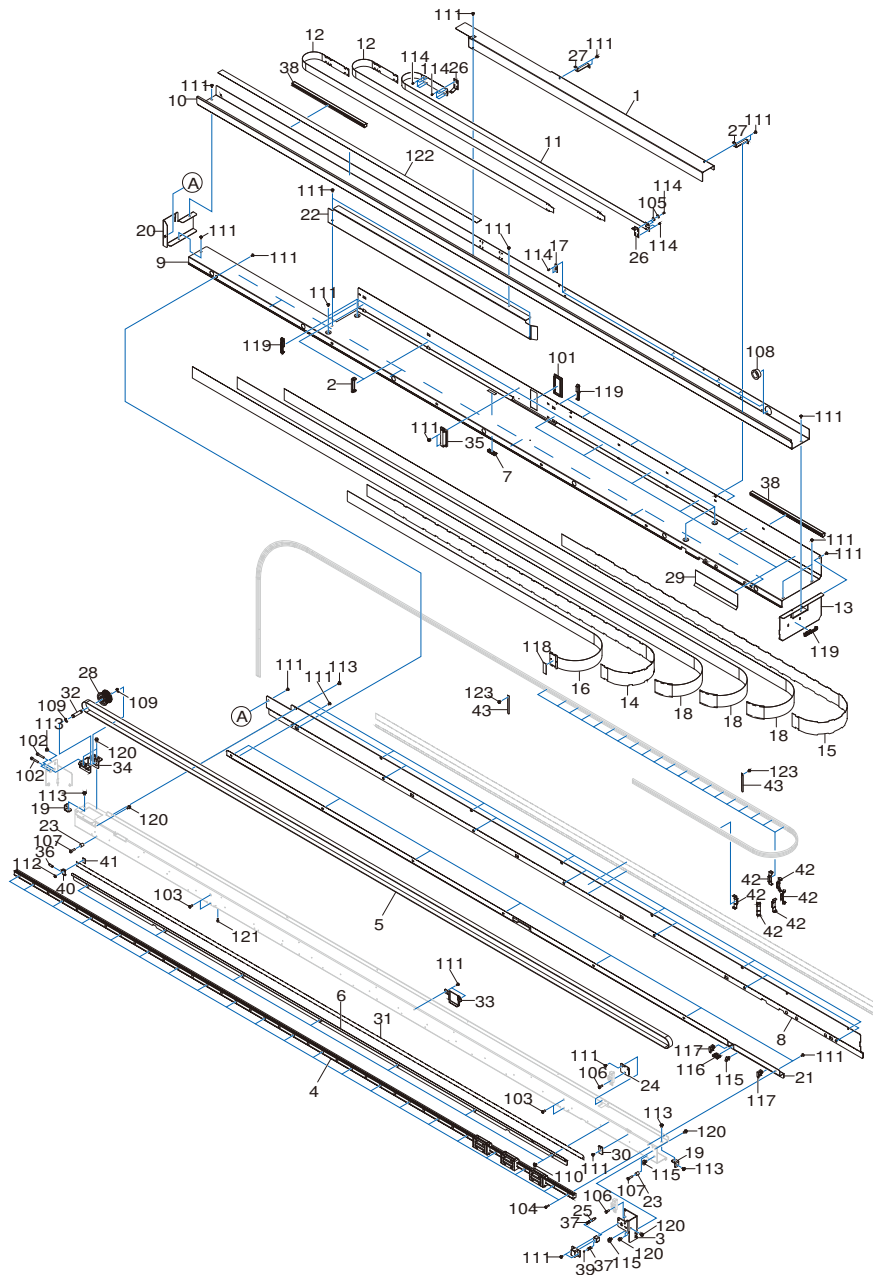

Pos	Code	Description
1	1000015370	SUPPORT,CUT CABLE SG-540
2	1000015378	GUIDE,TUBE SG-540
3	1000015351	STAY,LOCK SG-540
4	1000015357	L-BEARING,SSR15XW1GGC1E/2GC1E+2320L
5	1000015650	BELT,150S2M2459LW-C
6	1000015359	RAIL,LINER SCALE SG-540
7	1000015160	GASKET,STGH 5-8 L=30MM
8	1000019728	PLATE,RAIL REAR 2 CG2075
9	1000019725	FRAME,SUPPORT RAIL CG2075
10	1000019041	GUIDE,CUT CABLE CG2075
11	1000015658	PLATE,CUT CABLE VG-540
12	1000015380	SHEET,CUT CABLE SG-540
13	1000015367	COVER,RAIL SIDE R SG-540
14	1000015372	HOLDER,CABLE F SG-540
15	1000015373	HOLDER,CABLE SG-540
16	1000015647	PLATE,HOLDER CABLE VG-540
17	1000015428	PLATE,CABLE SLIT SG-540
18	1000020084	SHEET,HOLDER CABLE VG-540TH
19	1000015362	STAY,RAIL GUIDE SG-540
20	1000018776	COVER,RAIL SIDE L CG2076
21	1000019723	STAY,RAIL UNDER CG2075
22	1000015371	SUPPORT,GUIDE CABLE SG-540
23	31129102	PIPE SET,POLYCA 4*8*10 20PCS
24	1000019040	PLATE,CUT ORIGIN CG2076 TH
25	1000012944	SHAFT,LOCK CJ-70
26	1000015101	PLATE,GND C VG-640
27	1000020082	STAY,GND VG-640TH
28	1000001904	PULLEY,T55P2S16(B21C26)
29	1000012983	SHEET,FRAME SUPPORT RAIL VP-540
30	22135441	STOPPER,LINER SCALE FJ-540
31	1000003665	SHEET,LINER SCALE XJ-540
32	1000012957	SHAFT,IDLE PULLEY XC-540
33	1000018784	HOLDER,STOPPER SHAFT SQ CG2076
34	1000001555	HOLDER,IDLE PULLEY XC-540
35	11769118	CLAMP,FCM2-S6-14
36	22175122	SPRING,BACK UP PNC-960
37	22175134	SPRING,A CJ-70
38	1000015159	GASKET,STGH 10-10 L=300MM
39	11869103	BALL,4MM
40	1000012985	HOLDER,LINER SCALE CJ-70

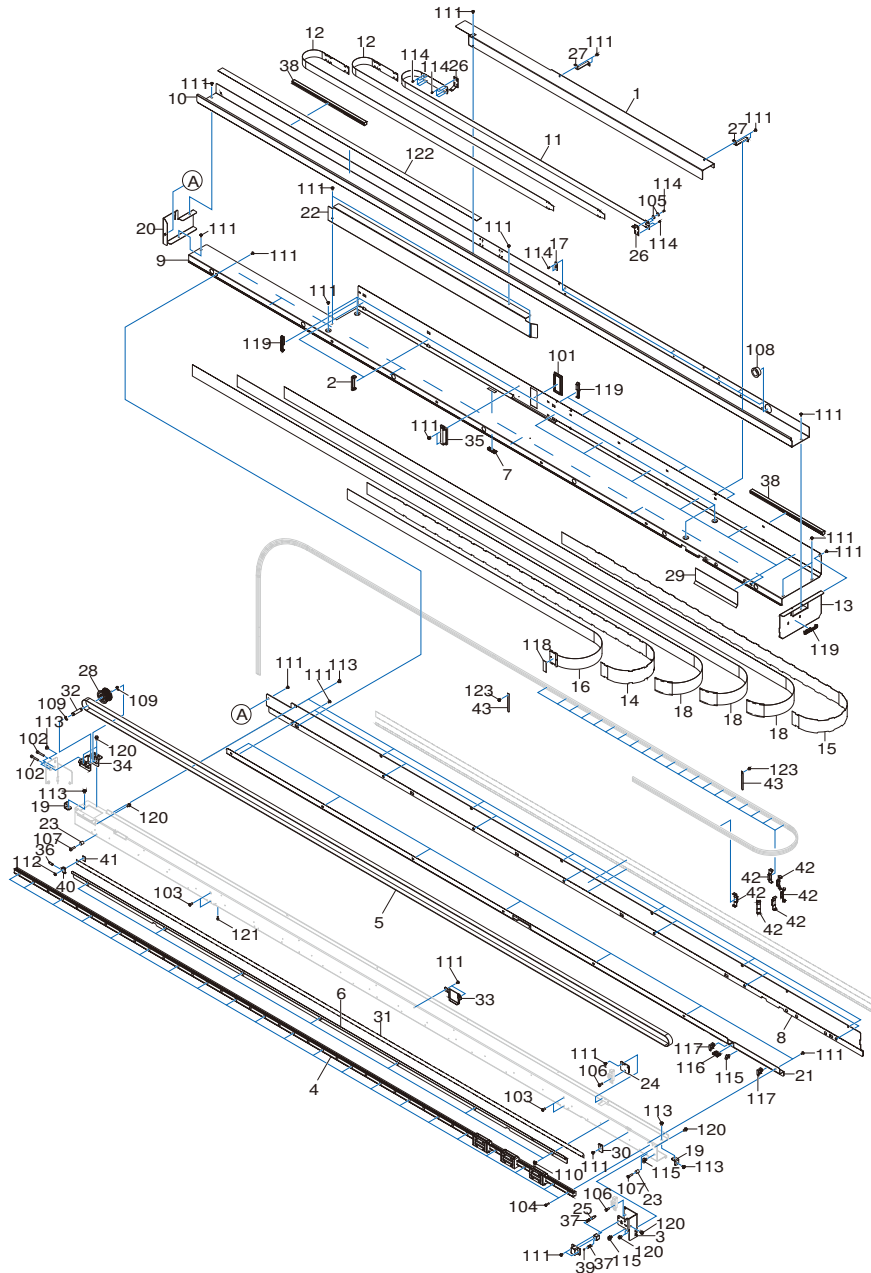

Pos	Code	Description
41	22055316	PLATE,LINEAR SCALE CJ-70
42	1000015378	GUIDE,TUBE SG-540
43	1000015103	PLATE,GND P VG-640
101	31029106	BUSH,SQUARE SB-6025
102	3000000423	CAP-SCREW,4*25 3CBC 100PCS
103	3000000400	CAP-SCREW,4*10 NI NS ULTRA LOW HEAD
104	3000000424	CAP-SCREW,3*12NI WSH 3*6*0.5
105	3000000259	WASHER SET,POM CC-0310-10 20PCS
106	3000000426	CAP-SCREW,4*10 NI 100PCS
107	3000000427	CAP-SCREW,4*15 NI 100PCS
108	31029101	BUSH,NB-19
109	31149704AS	RING SET,E-RING ETW-6 SUS 100 PCS
110	3000000428	W-SEMS,3*8(W=12*1)NI 100PCS
111	31289102AS	CUPSCREW SET,M3*6 NI 50 PCS.
112	31289109AS	CUPSCREW SET,M3*4 NI 100 PCS
113	31289111AS	CUPSCREW SET, M4*6 NI 100 PCS.
114	31299102AS	RIVET SET,NYLON P2655B 20 PCS.
115	31329501AS	CLAMP SET,PUSH MOUNT RT30SSF5 20P
116	31409702	SADDLE SET,LOCKING WIRE LES-1010 20P
117	3000000560	SADDLE,LOCKING WIRE LWS-0711Z_TH
118	3000000521	TAPE,FILAMENT 3M #898 12MMX50M
119	3000000033	CLAMP,WIRE PLESS RFC-45VO
120	3000000172	SCREW SET,CAP M4*8 NI WSH4*9*0.8 20P
121	3000000425	CAP-SCREW,3*8 NI 100PCS
122	3000000310	TAPE,TO.13XW20MMXL40M
123	31049154AS	SCREW SET,CAP M3*6 NI+PW 20 PCS

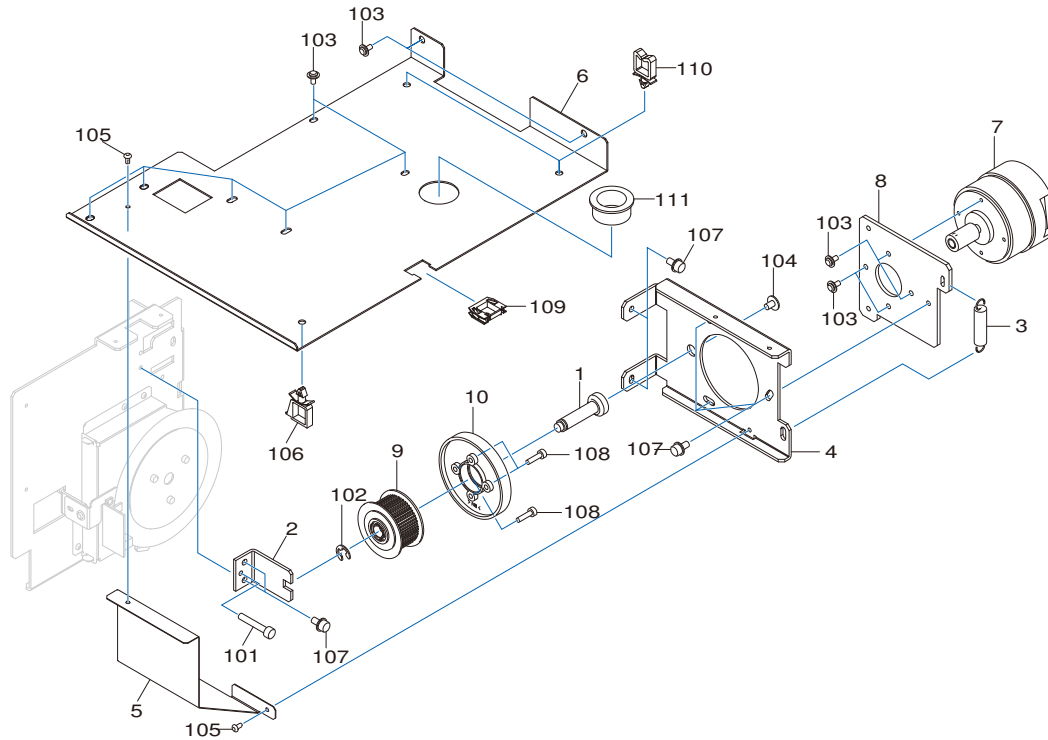

Pos	Code	Description
1	1000012807	SHAFT,DRIVE PULLEY XC-540
2	1000020056	STAY,SHAFT DRIVE PULLEY VP-540TH
3	22175157	SPRING,C P-ROLLER CM-500
4	1000020072	BASE,SCAN DRIVE VG-640TH
5	1000020083	COVER,SCAN MOTOR VG-640TH
6	1000017361	SUPPORT,SCAN MOTOR CG2032
7	6000002333	ASSY,SCAN MOTOR SV VG-640
8	1000015356	FLANGE,MOTOR SCAN SG-540
9	6700469030	ASSY,PULLEY VP-540
10	1000001905	GEAR,H187S20(B8)
101	3000000423	CAP-SCREW,4*25 3CBC 100PCS
102	31149704AS	RING SET,E-RING ETW-6 SUS 100 PCS
103	31289102AS	CUPSCREW SET,M3*6 NI 50 PCS.
104	31289111AS	CUPSCREW SET, M4*6 NI 100 PCS.
105	31299102AS	RIVET SET,NYLON P2655B 20 PCS.
106	31409811AS	SADDLE SET,LOCKING WIRE LWS-1211Z 20P
107	3000000172	SCREW SET,CAP M4*8 NI WSH4*9*0.8 20P
108	31049171AS	SCREW SET,CAP M3*12 NI 50 PCS.
109	31409702	SADDLE SET,LOCKING WIRE LES-1010 20P
110	3000000216	SADDLE,WIRE WS-2N-V0
111	31029101	BUSH,NB-19

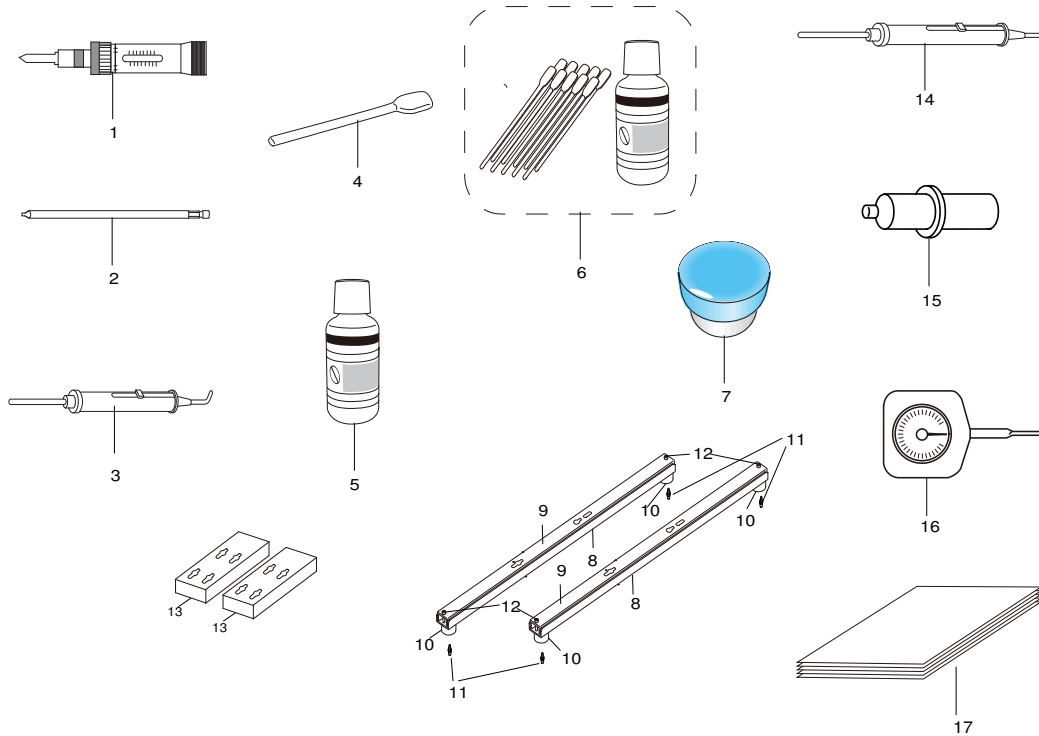

Pos	Code	Description
1	ST-056	TORQUE DRIVER N6
2	1000015274	BIT,PHILLIPS NO.2 L200MM
3	ST-001	TENSION GAUGE 2000GF/2000CN
4	1000003138	SET,CLEANER STICK TX712A 10PCS.
4	1000007172	CLEANER SET,STICK TX712A 100PCS
5	6000004663	CLEANING LIQUID(TR2-CL) SV 500ML
6	6000004662	KIT,CLEANING(TR2-CL) SV 100ML
7	6000004129	GREASE,FLOIL G-902 10ML_02
8	1000020778	ARM,PACKING L SV CG2076
9	1000020777	ARM,PACKING U SV CG2076
10	11879107	ABSORBER TK-12
11	31049157	SCREW,CAP M6*20 3CBC+PW+SW
12	31049125	SCREW,CAP M6*30 NI
13	1000020779	STAY,SHOULDER STRAP SV CG2076
14	ST-002	TENSION GAUGE 300GF/300CN
15	ST-006	WHITE DUMMY PEN
16	ST-012	DIAL TENSION METER DTB-50
17	1000009835	MEDIA,PET2-G 5SHEET SET 320MM ST-129

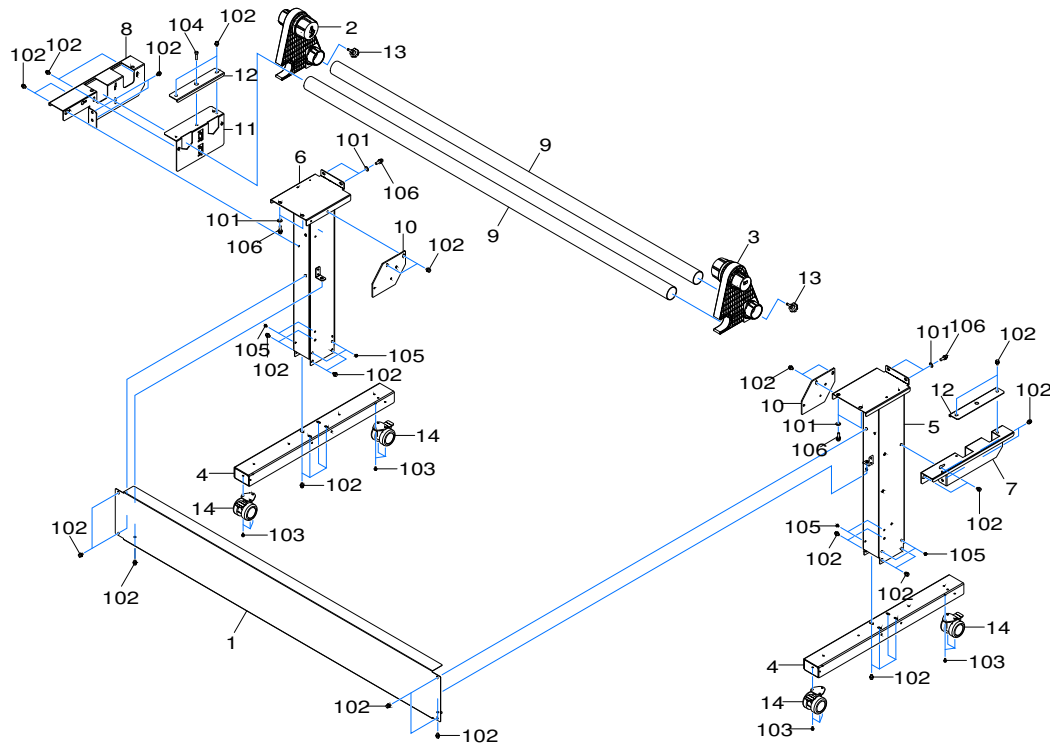

Pos	Code	Description
1	1000015330	STAY,STAND SG-540
2	6000003537	ASSY,FEEDER HOUSING L SV VG-640 T
3	6000003538	ASSY,FEEDER HOUSING R SV VG-640 T
4	1000019694	ASSY,BASE STAND CG2076
5	1000019692	ASSY,STAND LEG R CG2076
6	1000019693	ASSY,STAND LEG L CG2076
7	1000018228	ARM,R FEEDER CG2075
8	1000018229	ARM,L FEEDER CG2075
9	1000015601	PIPE,FEEDER SHAFT RS-540
10	1000019695	ADAPTER,DU CG2076
11	1000018230	STAY,FEED ADJUSTER CG2075
12	1000018231	STOPPER,FEEDER SHAFT CG2075
13	1000014294	KNOB,KG-B1 M6X30
14	1000003892	CASTER,STAND XJ-740
101	31249220AS	WASHER SET,PLAIN 6.5*16*1 NI 100PCS
102	3000000550	CAP-SCREW,6*10 3CBC SPW+WSH 6*12.5
103	31049169AS	SCREW SET,CAP M4*8 3CBC+PW 20PCS
104	31049124AS	SCREW SET,CAP M6*25 NI 20 PCS
105	31239106AS	SCREW SET,W-SEMS M4*8 3CBC 50 PCS
106	31049157	SCREW,CAP M6*20 3CBC+PW+SW

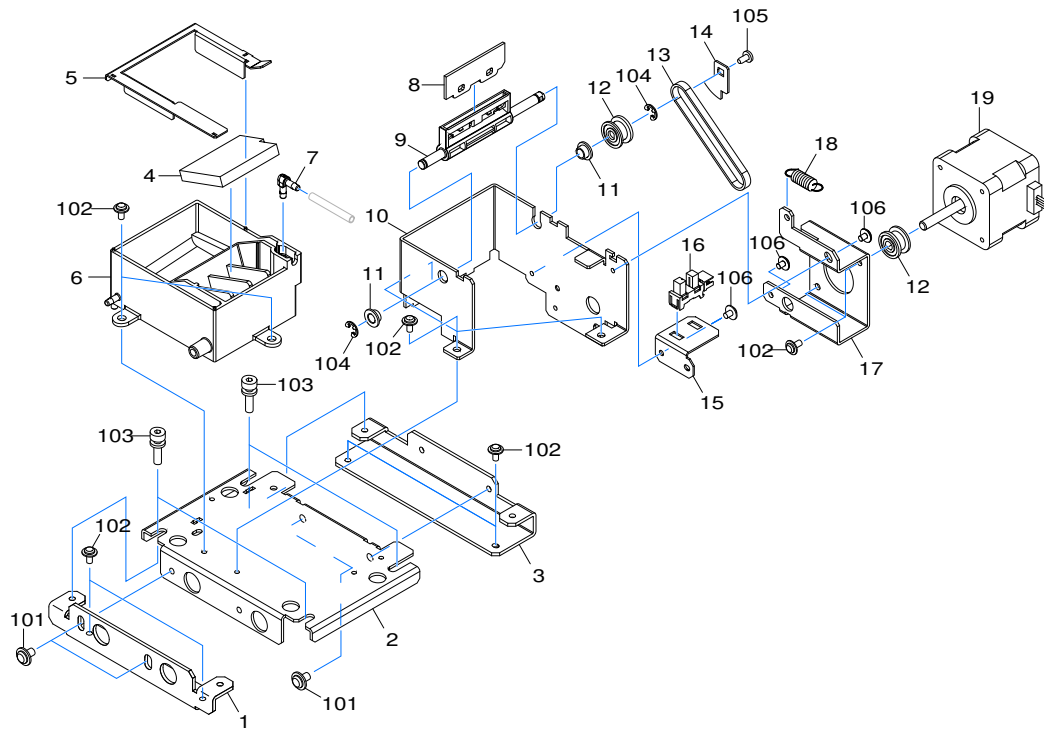

Pos	Code	Description
1	1000015453	STAY,ADJUSTER F WIPE SG-540
2	1000016841	FRAME,BASE WIPER SG-540_01
3	1000015454	STAY,ADJUSTER R WIPE SG-540
4	1000020059	PAD,CLEANER D VG-640TH
5	1000019749	COVER,WIPER CG2076
6	1000019760	TRAY,LIQUID WIPER CG2076
7	1000017901	ADAPTER,JOINT 3L CG2023
8	1000014754	WIPER,HEAD VG-640
9	1000014755	HOLDER,WIPER 2 VG-640
10	1000015448	FRAME,WIPER SG-540
11	1000018501	BUSH,80F-0503
12	22565406	DRIVE PULLEY
13	1000005794	BELT,146P2M4-530
14	1000014762	PLATE,WIPER SENSOR VG-640
15	1000015449	STAY,WIPER SENSOR SG-540
16	1000011069	SENSOR-INTERRUPTER,OJ-535S-A5
17	1000015451	HOLDER,WIPER MOTOR SG-540
18	1000015186	SPRING,PINCH 930 FJ-540
19	1000018516	MOTOR,103-593-1041
101	31289111AS	CUPSCREW SET, M4*6 NI 100 PCS.
102	31289102AS	CUPSCREW SET,M3*6 NI 50 PCS.
103	31179106	SCREW,JACK UP SP-540V
104	31149703AS	RING SET,E-RING ETW-4 100 PCS.
105	31019702AS	SCREW SET,BIND P-TIGHT M3*6 3C 100P
106	31289109AS	CUPSCREW SET,M3*4 NI 100 PCS

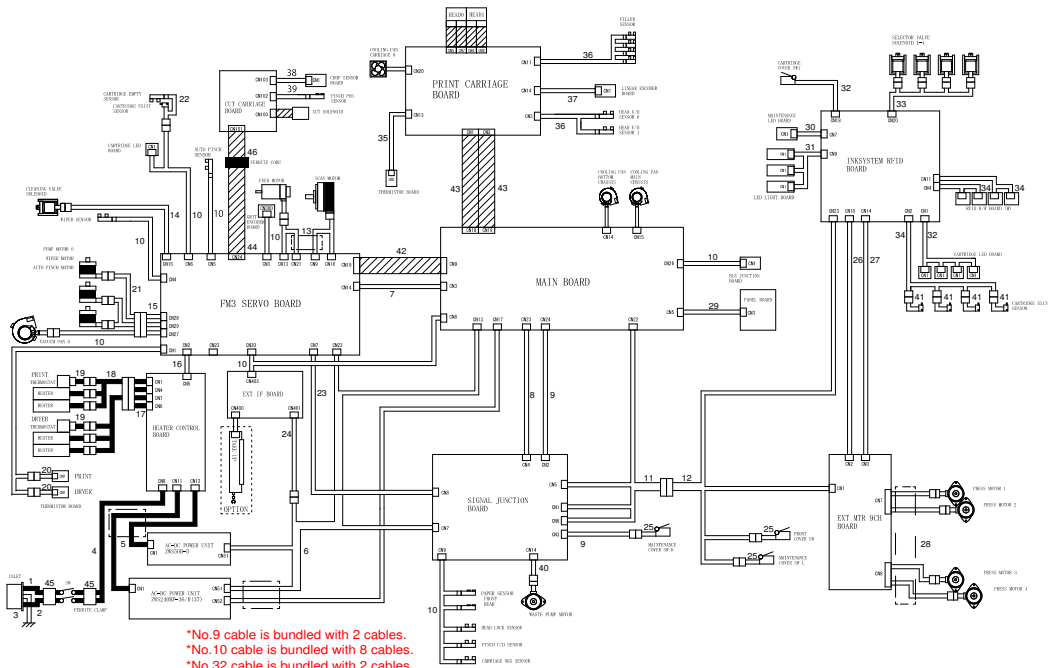

*No.9 cable is bundled with 2 cables.
 *No.10 cable is bundled with 8 cables.
 *No.32 cable is bundled with 2 cables.
 *No.34 cable is bundled with 3 cables.
 *No.36 cable is bundled with 2 cables.

Pos	Code	Description
1	1000018824	CABLE-ASSY,JUNBI A SJ-1000 T
2	1000018825	CABLE-ASSY,JUNBI B SJ-1000 T
3	1000018826	CABLE-ASSY,JUNBI G SJ-1000 T
4	1000017389	CABLE-ASSY,POWER AC-HCB CG2032
5	1000017400	CABLE-HARNESS,POWER AC CG2032
6	1000019549	CABLE-HARNESS,POWER DC CG2075
7	1000019507	CABLE-ASSY,SERVO UART CG2075
8	1000017391	CABLE-ASSY,F-SENS SERIAL CG2032
9	1000017414	CABLE-HARNESS,SIGNAL R-COVER CG2032
10	1000019551	CABLE-HARNESS, SENSORS CG2075_01
11	1000019513	CABLE-ASSY,M-I CAN JUNC CG2075
12	1000019514	CABLE-ASSY,M-I CAN CG2075
13	1000019552	CABLE-HARNESS,SERVO CL VALVE CG2075
14	1000019517	CABLE-ASSY,CLEANING VALVE CG2075
15	1000018530	CABLE-ASSY,P-W-F MTR JUNC CG2075
16	1000017395	CABLE-ASSY,HEATER CTL CG2032
17	1000017396	CABLE-ASSY,HEATER JUNC CG2032
18	1000017397	CABLE-ASSY,HEATER CG2032
19	1000015608	CABLE-ASSY,THERMOSTAT SG-540
20	1000017237	CABLE-ASSY,THERMISTOR EJ-640 TH
21	1000020758	CABLE-ASSY,P-W-F MTR CG2092_00
22	1000018849	CABLE-ASSY,CARTRIDGE UNIT VG-640 T
23	1000019518	CABLE-ASSY,EXT CTL 1 CG2075
24	1000019519	CABLE-ASSY,POWER DC EXT IF CG2075
25	1000019520	CABLE-ASSY,COVER SW CG2075
26	1000019521	CABLE-ASSY,EXT CTL 2 CG2075
27	1000019522	CABLE-ASSY,EXT POWER CG2075
28	1000020760	CABLE-HARNESS,PRESS PUMP CG2092_00
29	1000017392	CABLE-ASSY,PANEL CG2032
30	1000019527	CABLE-ASSY,MAINTENANCE LED CG2075
31	1000020761	CABLE-ASSY,INSIDE LED CG2092_00
32	1000020763	CABLE-HARNESS,LED CG2092_00
33	1000020764	CABLE-ASSY,SELECTOR SOL CG2092_00
34	1000019556	CABLE-HARNESS,INK MOD 0 CG2075
35	1000014552	CABLE-ASSY,CARRIAGE TH VG-640
36	1000019559	CABLE-HARNESS,FILLER H-UD CG2075
37	1000019544	CABLE-ASSY,L-ENCODER CG2075
38	1000019565	CABLE-ASSY,CROP SENS CG2075_01
39	1000019566	CABLE-ASSY,P-POS SENS CG2075_01
40	1000019546	CABLE-ASSY,WASTE PUMP MTR CG2075

Pos	Code	Description
41	1000020105	CABLE-ASSY,CARTRIDGE UNIT CG2075
42	1000015569	CABLE-CARD,22P1 75L BB HIGH-V
43	1000020655	CABLE-CARD,40P1-3150L-100T
44	1000017417	CABLE-CARD,15P1 2800L BB HIGH-V
45	1000006283	FILTERE,TFT-081610N
46	1000015262	FILTER(E),FPCR17-9-0.5

