

Pos	Code	Description
1	1000017519	PAD,FEEDER SV SG-540
2	1000015145	PAD,STAND VG-640
2	1000015714	PAD,STAND SG-540
2	1000017510	PAD,STAND SV SG-540
3	1000015146	CARTON,STAND VG-640
3	1000015715	CARTON,STAND SG-540
3	1000017511	CARTON,STAND SV SG-540
4	1000014611	PAD,PIPE FEEDER SHAFT EJ-640
4	1000015711	PAD,PIPE FEEDER SHAFT SG-540
4	1000017508	PAD,PIPE FEEDER SHAFT SV SG-540
5	1000015716	CARTON,SLEEVE SG-540
5	1000017512	CARTON,SLEEVE SV SG-540
6	1000015729	STOPPER,PINCH ROLLER SG-540
6	1000017517	STOPPER,PINCH ROLLER SV SG-540
7	1000017520	CARTON,SPACER SV SG-540
8	1000015724	PAD,L-LEFT SG-540
8	1000017515	PAD,L-LEFT SV SG-540
9	1000015725	PAD,L-RIGHT SG-540
9	1000017516	PAD,L-RIGHT SV SG-540
10	1000017521	PAD,CENTER SV SG-540
11	1000015718	CARTON,COVER SG-540
11	1000017513	CARTON,COVER SV SG-540
12	1000015723	TRAY,SKID SG-540
12	1000019080	TRAY,SKID SV SG-540_01
13	1000015150	PAD,U-LEFT VG-640
13	1000015719	PAD,U-LEFT SG-540
13	1000017514	PAD,U-LEFT SV SG-540
14	1000015151	PAD,U-RIGHT VG-640
14	1000015730	PAD,U-RIGHT SG-540
14	1000017518	PAD,U-RIGHT SV SG-540
15	1000017522	PAD,VKIT SV SG-540
16	1000015712	PAD,SUPPORT FEEDER SHAFT SG-540
16	1000017509	PAD,SUPPORT FEEDER SHAFT SV SG-540
17	1000017523	PAD,ACCESSORY SV SG-540
18	22535532	LABEL,CARTON CARE #LA762
19	1000016464	LABEL,CARTON SG-540#LA2472
20	1000014622	PAD,SUPPORT EJ-640

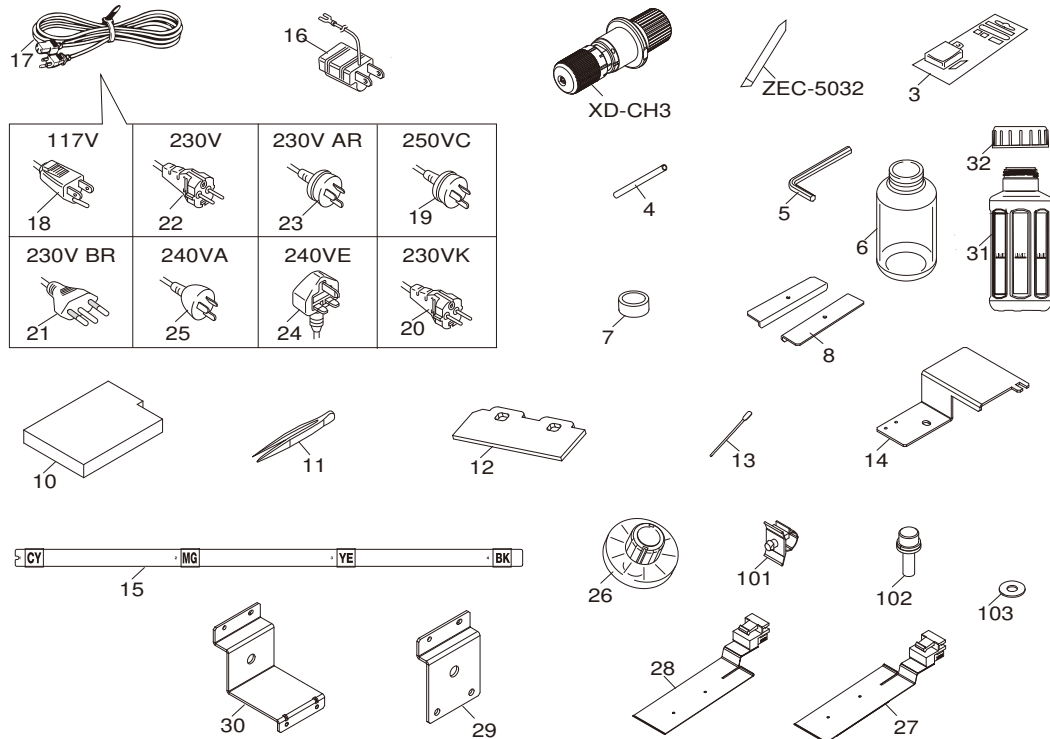

Pos	Code	Description
3	11849102	BLADE,OLFA AUTO CUTTER XB10
4	22155133	PIPE,TOOL D9*L150 FJ-540
5	22565682	HEXAGONAL WRENCH 5
6	11369115	CASE,PP BOTTLE
7	22335143	CAP,EPDM
8	100003635	STOPPER,PIPE FEEDER XJ-740
10	1000014464	PAD,CLEANER D VG-640
10	1000020059	PAD,CLEANER D VG-640TH
11	12569656	TWEEZERS PTS-01
12	1000014754	WIPER,HEAD VG-640
13	1000003138	SET,CLEANER STICK TX712A 10PCS.
13	1000007172	CLEANER SET,STICK TX712A 100PCS
13	ST-037	CLEAN STICK TX712A
14	1000015489	STOPPER,CARRIAGE SG-540
15	1000015750	LABEL, SET INK SG-540#LA2351
16	13499209	ADAPTER PLUG (100V)
17	1000005832	CABLE-AC,100V 15A 2.5M 3P
18	1000005833	CABLE-AC,117V 15A 2.5M 3P
19	13439801	CABLE-AC 3P CHINA 10A250V S
20	1000010999	CABLE-AC, H05VV 230V 10A KC
21	1000006571	CABLE-AC,3P 117/230V BR 2.5M
22	23495125	AC-CORD H05VV 230V 10A S
23	1000006097	CABLE-AC,3P 230VAR 2.5M TW
24	13499111	AC CORD H05VV-F 240VE 10A S
25	23495124	AC CORD 3ASL100 240VA 10A SAA
26	21995106	FLANGE,GUIDE 2 PNS-70
27	6000002862	ASSY,MEDIA CLAMP R SG-540
28	6000002863	ASSY,MEDIA CLAMP L SG-540
29	1000015177	PLATE,FRAME R UNDER 2 TUC-2
30	1000015176	BRACKET,FRAME R UNDER 2 TUC-2
31	1000019429	CASE,DRAIN BOTTLE 1.0L
32	1000019580	CAP,PP BOTTLE 5-002-04
101	31379111	CLAMP,CABLE CKS-13-H
102	31049157	SCREW,CAP M6*20 3CBC+PW+SW
103	31249220AS	WASHER SET,PLAIN 6.5*16*1 NI 100PCS

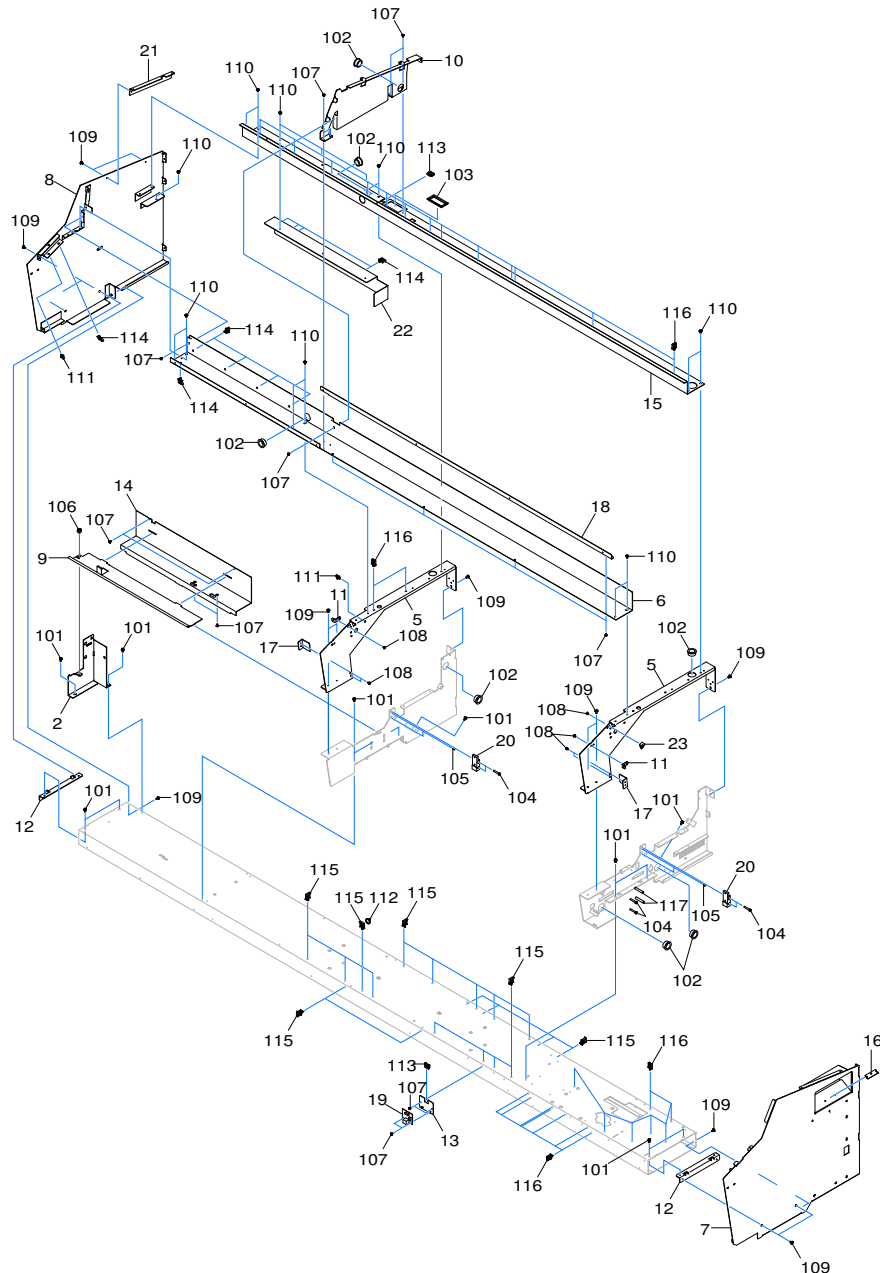

Pos	Code	Description
2	1000015311	STAY,SUPPORT RAIL L SG-540
5	1000015322	SUPPORT,FRAME SG-540
6	1000015307	SUPPORT,COVER SG-540
7	1000015308	FRAME,SIDE R SG-540
8	1000015313	FRAME,SIDE L SG-540
9	1000015314	FRAME,AUTOCUTTER SG-540
10	1000015315	COVER,SIDE INK SYSYTEM SG-540
11	1000015316	STAY,COVER ARM SG-540
12	1000015317	STAY,FRAME SG-540
13	1000015318	STAY,EXT BOARD SG-540
14	1000015319	STAY,MAINTENANCE LED SG-540
15	1000015309	PLATE,INK CARTRIDGE SG-540
16	1000014825	LABEL,CL VG-640#LA2170
17	1000014828	STOPPER,COVER FRONT VG-640
18	1000015310	STAY,SUPPORT COVER S SG-540
19	W704220000	ASSY,EXT IF SG-540
20	1000002589	BASE,RAIL VP-540
21	1000015321	SUPPORT,FRAME SIDE L SG-540
22	1000015749	HOLDER,TUBE SG-540
23	1000015323	SUPPORT,STAY PANEL SG-540
101	3000000172	SCREW SET,CAP M4*8 NI WSH4*9*0.8 20P
102	31029101	BUSH,NB-19
103	31029106	BUSH,SQUARE SB-6025
104	3000000423	CAP-SCREW,4*25 3CBC 100PCS
104	31049137AS	SCREW SET,CAP M4*25 3CBC 20 PCS
105	31119904	PIN,SPRING 2.5*8 SUS STRAIGHT 50 PCS
106	31139104	SCREW,PLAPOINT M4*6 BK FE
107	31289102AS	CUPSCREW SET,M3*6 NI 50 PCS.
108	31289105AS	CUPSCREW SET, M3*6 3CBC 100 PCS
109	31289110AS	CUPSCREW SET, M4*8 3CBC 100 PCS
110	31289111AS	CUPSCREW SET, M4*6 NI 100 PCS.
111	31329501AS	CLAMP SET,PUSH MOUNT RT30SSF5 20P
112	31329601AS	CLAMP SET,INSULOK T-18S 100 PCS.
113	31409702	SADDLE SET,LOCKING WIRE LES-1010 20P
114	3000000560	SADDLE,LOCKING WIRE LWS-0711Z_TH
114	31409801AS	SADDLE,LOCKING WIRE LWS-0711Z 20P
115	31409811AS	SADDLE SET,LOCKING WIRE LWS-1211Z 20P
116	3000000216	SADDLE,WIRE WS-2N-V0
117	21745101	COLLAR,P-ROLLER PNC-960

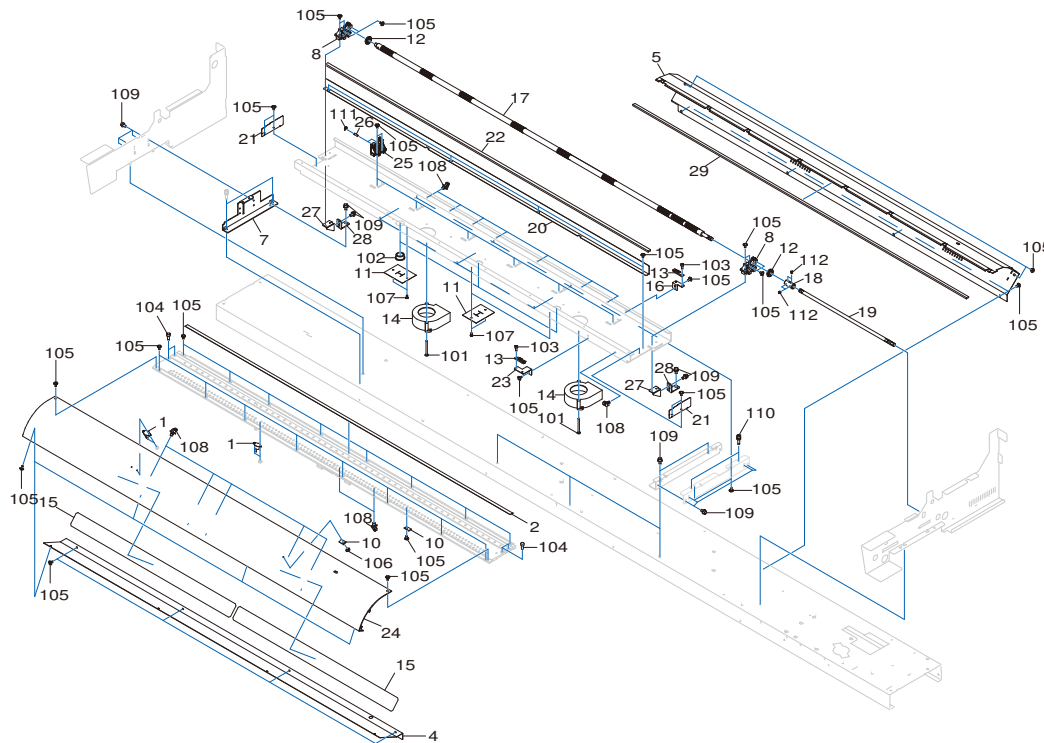

Pos	Code	Description
1	15099115	SENSOR-INTERRUPTER GP2A25NJ
2	1000015344	PAD,CUTTER SG-540
4	1000015346	APRON,F UNDER SG-540
5	1000017482	APRON,B SG-540_01
7	1000015735	FRAME,SIDE BED SG-540
8	1000015348	HOUSING,G-SHAFT SG-540
10	1000015534	ASSY,THERMISTOR BOARD SG-540
11	1000012964	SHUTTER,HEATER CORD SP-300
12	1000012579	R-BEARING,RNR-2210X9KK
13	15099115	SENSOR-INTERRUPTER GP2A25NJ
14	1000009934	FAN,9BAM24P2H06PJ
14	1000018515	FAN,9BAM24P2H06PJ
15	1000002165	ASSY,CORD HEATER VP-540
16	1000015736	STAY,PAPER SENSOR 2 SG-540
17	1000015335	SHAFT,G-ROLLER SG-540
18	1000015336	CUPLING,FEED SHAFT SG-540
19	1000015337	SHAFT,DRIVE F SG-540
20	1000015338	STAY,AIR SHEELD REAR SG-540
21	1000015339	STAY,AIR SHEELD SIDE SG-540
22	1000015340	CUSHION,AIR STOPPER SG-540
23	1000015341	STAY,PAPER SENSOR SG-540
24	1000015343	ASSY,APRON F SG-540
25	1000015349	STAY,BACKUP ROLLER SG-540
26	1000015350	SHAFT,BACKUP ROLLER SG-540
27	1000015737	SPACER,HOUSING UPPER SG-540
28	1000015738	SPACER,HOUSING LOWER SG-540
29	1000015739	CUSHION,AIR SEAL SG-540
101	31019124	SCREW SET,BINDING M3*35 NI 50 PCS
102	31029101	BUSH,NB-19
103	31049170AS	SCREW SET,CAP M3*8 NI 50 PCS.
104	31049173AS	SCREW SET,CAP M4*10 NI 50 PCS.
105	31289102AS	CUPSCREW SET,M3*6 NI 50 PCS.
106	31289109AS	CUPSCREW SET,M3*4 NI 100 PCS
107	31299102AS	RIVET SET,NYLON P2655B 20 PCS.
108	31329501AS	CLAMP SET,PUSH MOUNT RT30SSF5 20P
109	3000000172	SCREW SET,CAP M4*8 NI WSH4*9*0.8 20P
110	31179106	SCREW,JACK UP SP-540V
111	31149702AS	RING SET,E-RING ETW-3 100 PCS.
112	31199705AS	SCREW SET,SET WP M4*4 NI 20 PCS

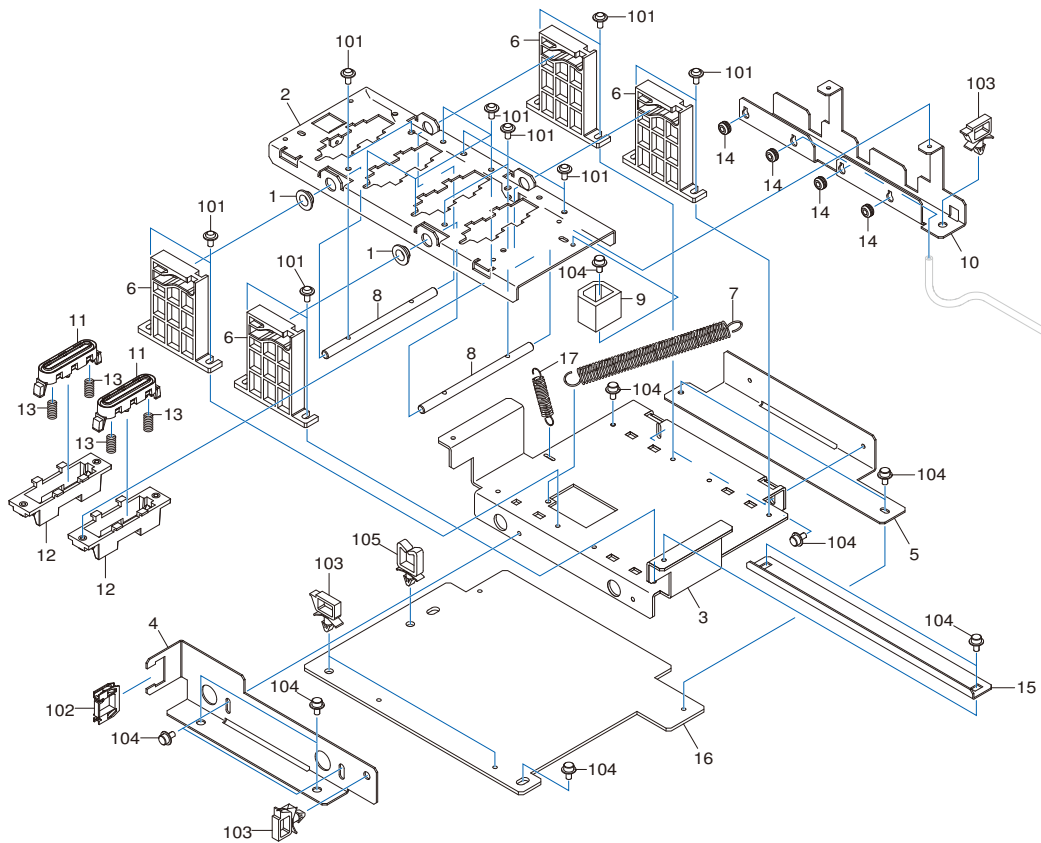

Pos	Code	Description
1	1000018512	BUSH,80F-0603
1	12159573	BUSH,80F-0603
2	1000015458	FRAME,BACKUP CAP SG-540
3	1000015460	FRAME,BASE CAP SG-540
4	1000015461	STAY,ADJUSTER F CAP SG-540
5	1000015462	STAY,ADJUSTER R CAP SG-540
6	1000014455	GUIDE,SLIDE CAP VG-640
7	1000015456	SPRING,CAP SLIDE SG-540
8	1000015457	SHAFT,CAP LIFT SG-540
9	1000014468	STOPPER,ARM CAP VG-640
10	1000015459	STAY,TUBE CAP SG-540
11	6000002332	ASSY,CAP TOP VG-640
11	6000004658	ASSY,CAP TOP SV CG2076
12	1000014760	HOLDER,CAP VG-640
13	1000015463	SPRING,CAP TOP K SG-540
14	1000015091	GROMET,RUBBER KG-74
14	1000020074	GROMET,RUBBER KG-74TH
15	1000015125	SUPPORT,GUIDE SLIDE CAP VG-640
15	1000020080	SUPPORT,GUIDE SLIDE CAP VG-640TH
16	1000015126	PLATE,CAP UNDER CAP VG-640
16	1000020068	PLATE,CAP UNDER VG-640TH
17	1000015183	SPRING,CAP SWING VS-640
101	31289102AS	CUPSCREW SET,M3*6 NI 50 PCS.
102	31409702	SADDLE SET,LOCKING WIRE LES-1010 20P
103	3000000560	SADDLE,LOCKING WIRE LWS-0711Z_TH
103	31409801AS	SADDLE,LOCKING WIRE LWS-0711Z 20P
104	31049154AS	SCREW SET,CAP M3*6 NI+PW 20 PCS
105	3000000216	SADDLE,WIRE WS-2N-V0

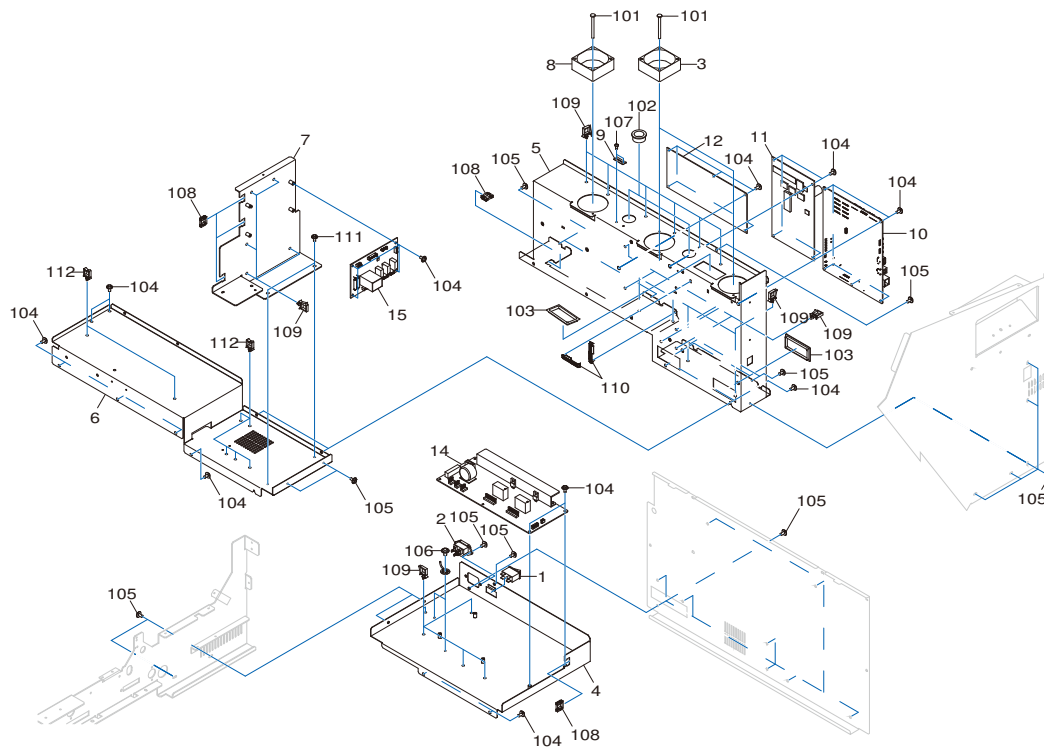

Pos	Code	Description
1	1000018525	SW,POWER AJ8201BF
2	13429702	INLET AC P01CF01 15A250V
3	1000006174	FAN,9A0624H414
4	1000015424	BASE,CHASSIS POWER SG-540
5	1000015423	BASE,CHASSIS BOARD SG-540
6	1000015426	STAY,CHASSIS COVER SG-540
7	1000015425	STAY,SERVO BOARD SG-540
8	1000014508	FAN,9A0624H422_620
9	1000015428	PLATE,CABLE SLIT SG-540
10	6000002695	ASSY,MAIN BOARD SG-540
11	1000016153	ASSY,FM3 SERVO BOARD VG-540 T
11	6000002193	ASSY,FM3 SERVO BOARD VG-640_01
12	1000015576	POWER UNIT,ZWD225PAF-0537/J
13	1000006283	FILTERE,TFT-081610N
14	1000015532	ASSY,HEATER CONTROL BOARD SG-540
14	1000018538	ASSY,HEATER CONTROL BOARD CG2075
15	1000015540	ASSY,SIGNAL JUNCTION BOARD SG-540
101	31019124	SCREW SET,BINDING M3*35 NI 50 PCS
102	31029101	BUSH,NB-19
103	31029106	BUSH,SQUARE SB-6025
104	31289102AS	CUPSCREW SET,M3*6 NI 50 PCS.
105	31289105AS	CUPSCREW SET, M3*6 3CBC 100 PCS
106	31289111AS	CUPSCREW SET, M4*6 NI 100 PCS.
107	31299102AS	RIVET SET,NYLON P2655B 20 PCS.
108	31409702	SADDLE SET,LOCKING WIRE LES-1010 20P
109	31409811AS	SADDLE SET,LOCKING WIRE LWS-1211Z 20P
110	3000000033	CLAMP,WIRE PLESS RFC-45VO
111	31289109AS	CUPSCREW SET,M3*4 NI 100 PCS
112	3000000216	SADDLE,WIRE WS-2N-V0

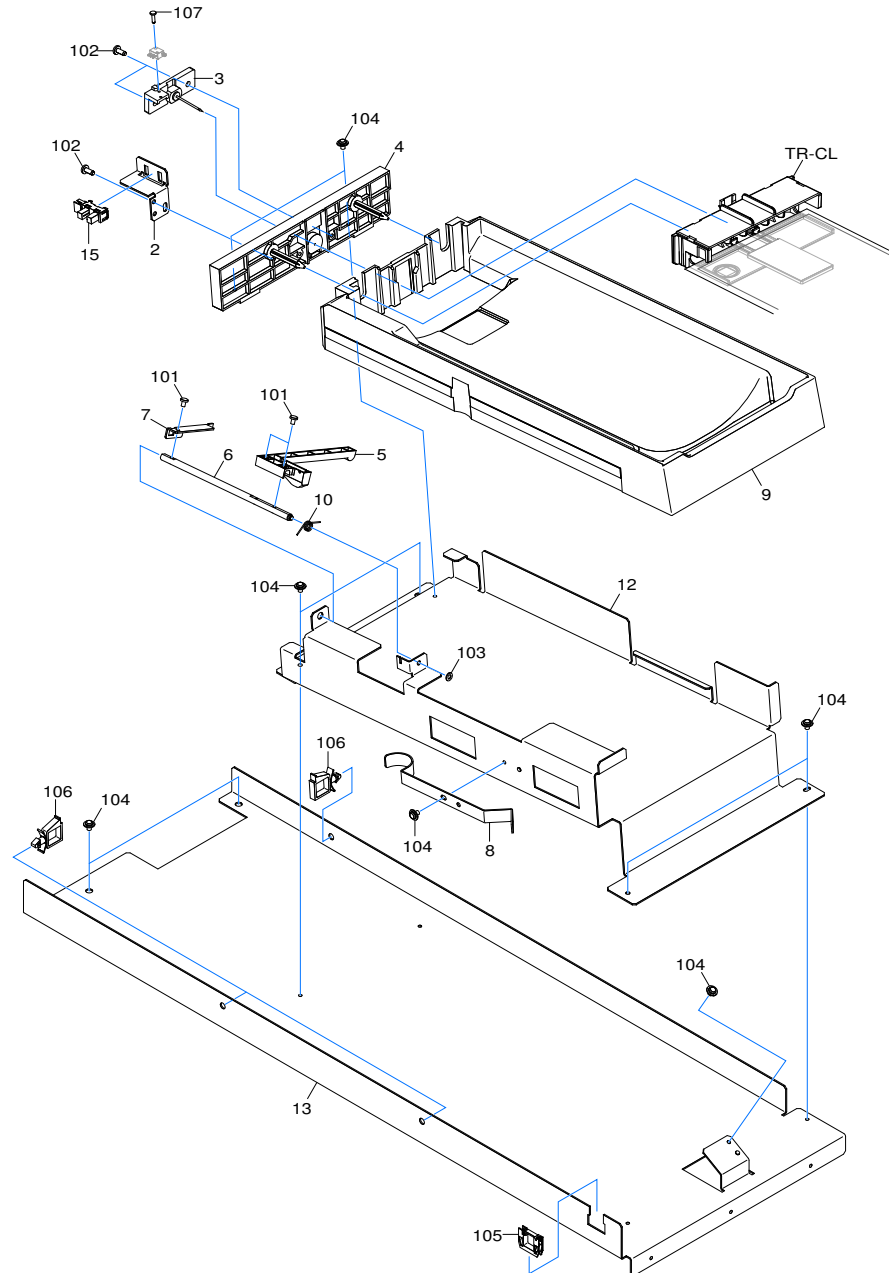

Pos	Code	Description
2	1000015444	STAY,INK EMPTY SENS SG-540
3	6000002739	ASSY,I/C NEEDLE HOLDER VG-640
4	1000014581	BASE, HOLDER NEEDLE VG-640
5	1000014582	LEVER,INK EMPTY VG-640
6	1000015442	SHAFT,INK EMPTY SG-540
7	1000015443	BLADE,INK EMPTY SG-540
8	1000014585	SPRING,PLATE I/C VG-640
9	1000014586	TRAY, INK POUCHES VG-640
10	1000014587	SPRING,LEVER INK EMPTY VG-640
12	1000017837	FRAME,HOLDER C/C SG-540_01
13	1000015432	BASE,CL CARTRIDGE SG-540
15	1000011069	SENSOR-INTERRUPTER,OJ-535S-A5
101	31019148AS	SCREW SET,BINDING M2.6*4 NI 100 PCS
102	31019703	SCREW,BINDING P-TIGHT M3*8 3C 100P
103	31249952	WASHER SET,POLYSLIDER 2.6*5*.5 CUT 20PCS
104	31289109AS	CUPSCREW SET,M3*4 NI 100 PCS
105	31409702	SADDLE SET,LOCKING WIRE LES-1010 20P
106	31409811AS	SADDLE SET,LOCKING WIRE LWS-1211Z 20P
107	3000000412	BIND,P-TIGHT 2*8 3C 20PCS.

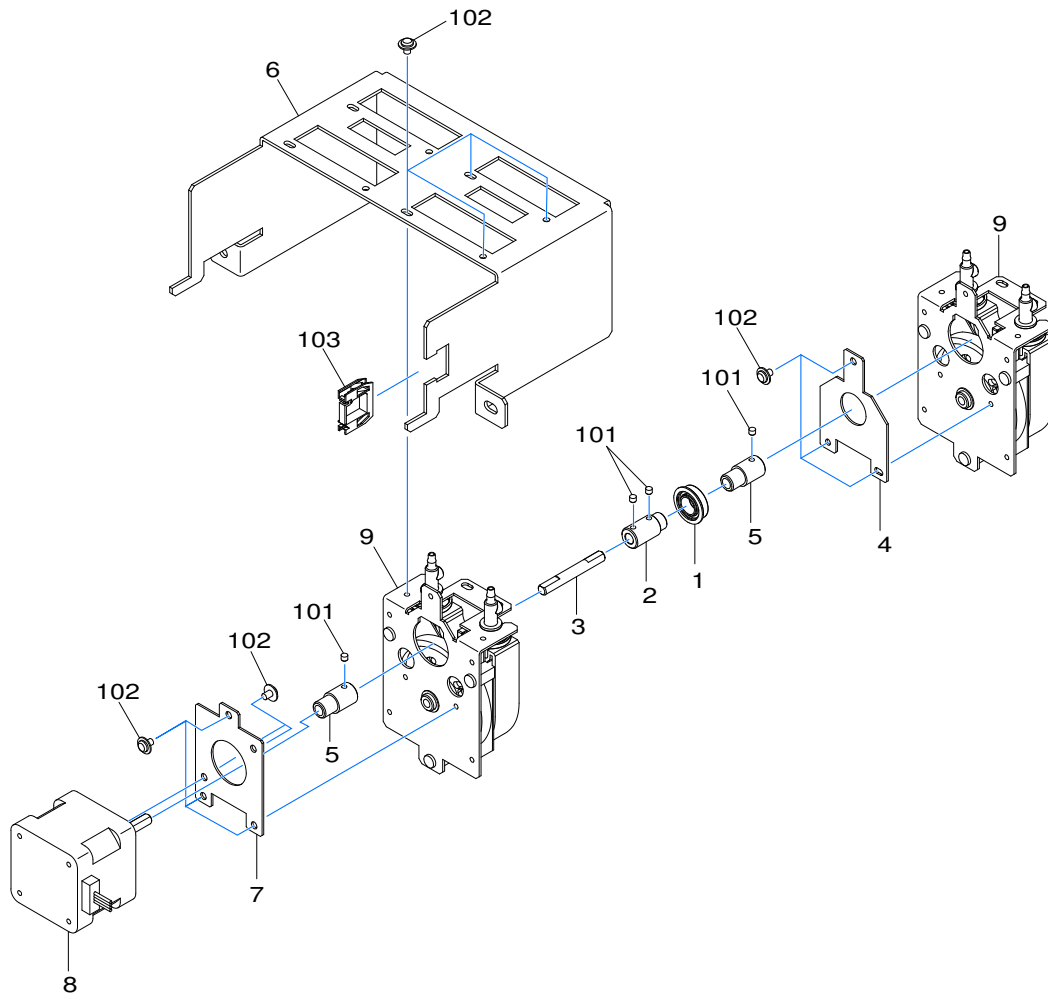

Pos	Code	Description
1	22175815	BEARING F8-16ZZ
2	1000015465	COUPLING,PUMP SG-540
3	1000015466	SHAFT,PUMP SG-540
4	1000002595	PLATE,P-BEARING VP-540
5	1000012988	GEAR,S10B20
6	1000015464	STAY,PUMP SG-540
7	1000001585	PLATE,P-MOTOR XC-540
7	1000020054	PLATE,P-MOTOR XC-540TH
8	1000007733	MOTOR,XS-5208-064
8	1000018514	MOTOR,103-5208-85542
9	6701219010	ASSY,CIRCULATING PUMP LEC-330
101	31199701AS	SCREW SET,SET WP M3*3 NI 20 PCS
102	31289109AS	CUPSCREW SET,M3*4 NI 100 PCS
103	31409702	SADDLE SET,LOCKING WIRE LES-1010 20P

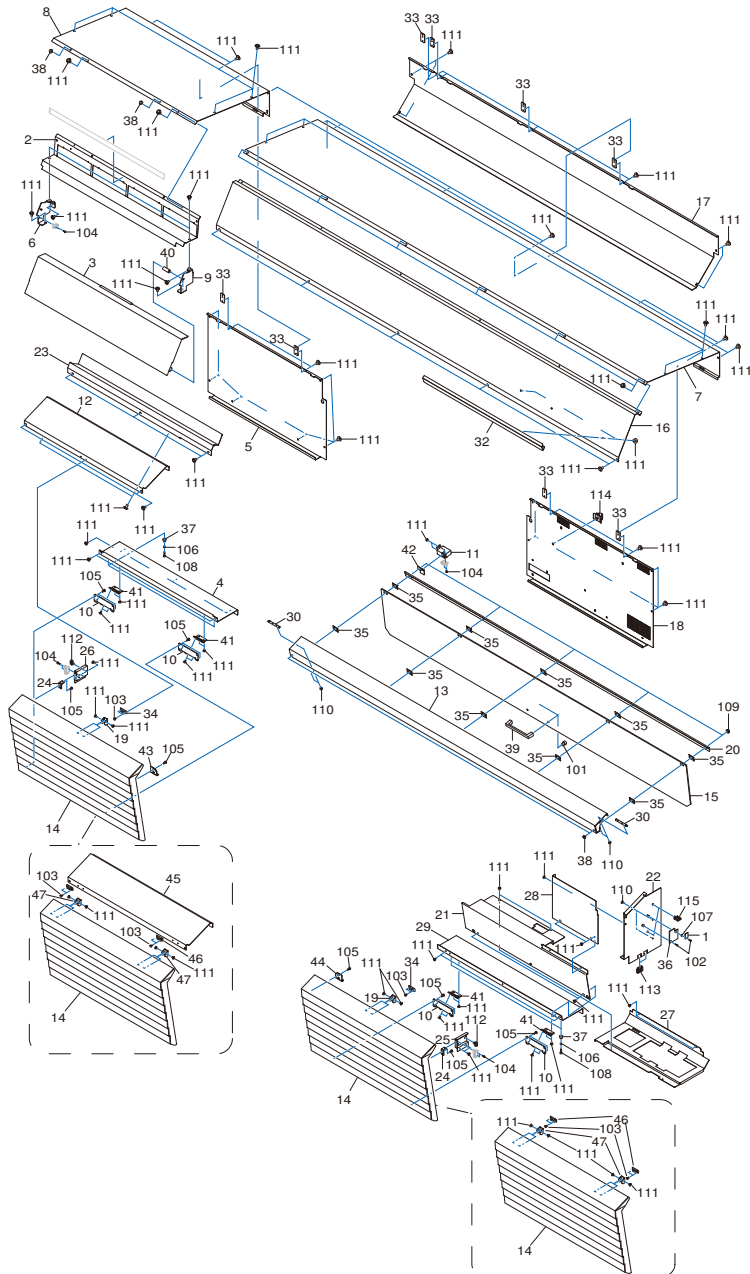

Pos	Code	Description
1	1000014067	BLE-MODULE,LBCA2ZZVZE-722
2	1000015396	COVER,INK PANEL SG-540
3	1000014364	COVER,INK CARTRIDGE VG-640
4	1000015402	COVER,UNDER L SG-540
5	1000015403	COVER,BACK L SG-540
6	1000015404	HINGE,COVER INK L SG-540
7	1000015397	COVER,TOP R SG-540
8	1000015398	COVER,TOP L SG-540
9	1000015405	HINGE,COVER INK R SG-540
10	1000015406	STAY,COVER SG-540
11	1000015419	STAY,COVER INT SG-540
12	1000014405	PLATE,COVER VG-640
12	1000015407	PLATE,COVER SG-540
13	1000015393	COVER,FRONT SG-540
14	1000014407	COVER,SIDE VG-640
15	1000015394	PLATE,FRONT COVER SG-540
15	1000017155	PLATE,FRONT COVER SG-540_01
16	1000015399	PLATE,COVER F SG-540
17	1000015400	COVER,RAIL SG-540
18	1000015408	COVER,CHASSIS SG-540
19	1000015409	STAY,COVER CATCH SG-540
19	1000019406	STAY,COVER CATCH 2 SG-540
20	1000015395	STAY,COVER FRONT SG-540
21	1000015416	COVER,MAINTENANCE F SG-540
22	1000015410	COVER,FEED MOTOR SG-540
23	1000015401	COVER,INK PANEL UNDER SG-540
24	1000015417	STAY,COVER M SW SG-540
25	1000015411	COVER,SW R SG-540
26	1000015412	COVER,SW L SG-540
27	1000014437	COVER,MAINTENANCE VG-640
27	1000015413	COVER,MAINTENANCE SG-540
27	1000016200	COVER,MAINTENANCE VG-640TH
28	1000015414	COVER,PANEL UNDER SG-540
28	1000019412	COVER,PANEL UNDER 2 SG-540
29	1000015415	COVER,UNDER R SG-540
30	1000015391	SHAFT,COVER FRONT SG-540
32	1000015418	DOCK,TABLET PC SG-540
33	1000015130	STAY,COVER LINK VG-640
33	1000017561	STAY,COVER LINK CG2032
34	1000010122	MAGNET,CLAMP MEDIA XF-640

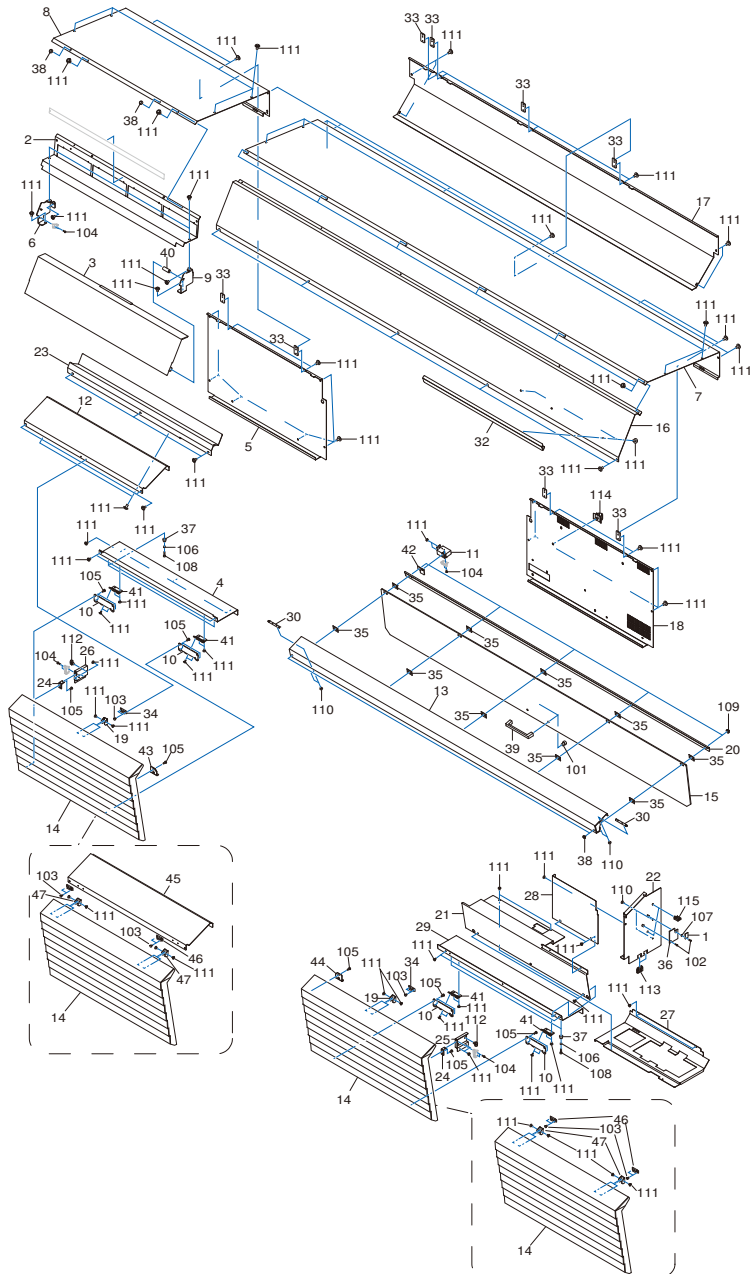

Pos	Code	Description
35	100020064	WASHER,COVER FJ-50TH
35	21425110	WASHER,COVER FJ-50
36	1000015537	ASSY,BLE JUNCTION BOARD SG-540
37	11879107	ABSORBER TK-12
38	12239406	CUSHION,TM-96-6
39	1000014578	KNOB,A-165-4
40	1000014485	DAMPER,TD75 B1-1K
41	1000014368	HINGE,BP-151-1
41	1000018506	HINGE,BP-151-1
42	1000015392	HOOK,INT SW SG-540
43	1000017830	STOPPER,COVER SIDE L VG-640
43	1000017889	STOPPER,COVER SIDE L VG-640TH
44	1000017829	STOPPER,COVER SIDE R VG-640
44	1000017888	STOPPER,COVER SIDE R VG-640TH
45	1000019408	PLATE,COVER 2 SG-540
46	1000019423	MAGNET,SM-133
47	1000019406	STAY,COVER CATCH 2 SG-540
101	3000000500	BIND,5*8 NI
102	3000000431	NABE,2.5*8 NI 20PCS.
103	31019135AS	SCREW SET,BIND M3*6 NI 100 PCS.
104	31019149	SCREW SET,BINDING M2.3*8 3CBC 100PCS
105	31019703	SCREW,BINDING P-TIGHT M3*8 3C 100P
106	31029802AS	BUSH SET,ROLL 3*3.5 3C 100PCS.
107	31029820	BUSH SET,ROLL 3*2 3C 50PCS
108	31049171AS	SCREW SET,CAP M3*12 NI 50 PCS.
109	31109801AS	NUT SET,HEXAGON M3 NI 100 PCS.
110	31289102AS	CUPSCREW SET,M3*6 NI 50 PCS.
111	31289105AS	CUPSCREW SET, M3*6 3CBC 100 PCS
112	31329501AS	CLAMP SET,PUSH MOUNT RT30SSF5 20P
113	31409702	SADDLE SET,LOCKING WIRE LES-1010 20P
114	31379111	CLAMP,CABLE CKS-13-H
115	3000000216	SADDLE,WIRE WS-2N-V0

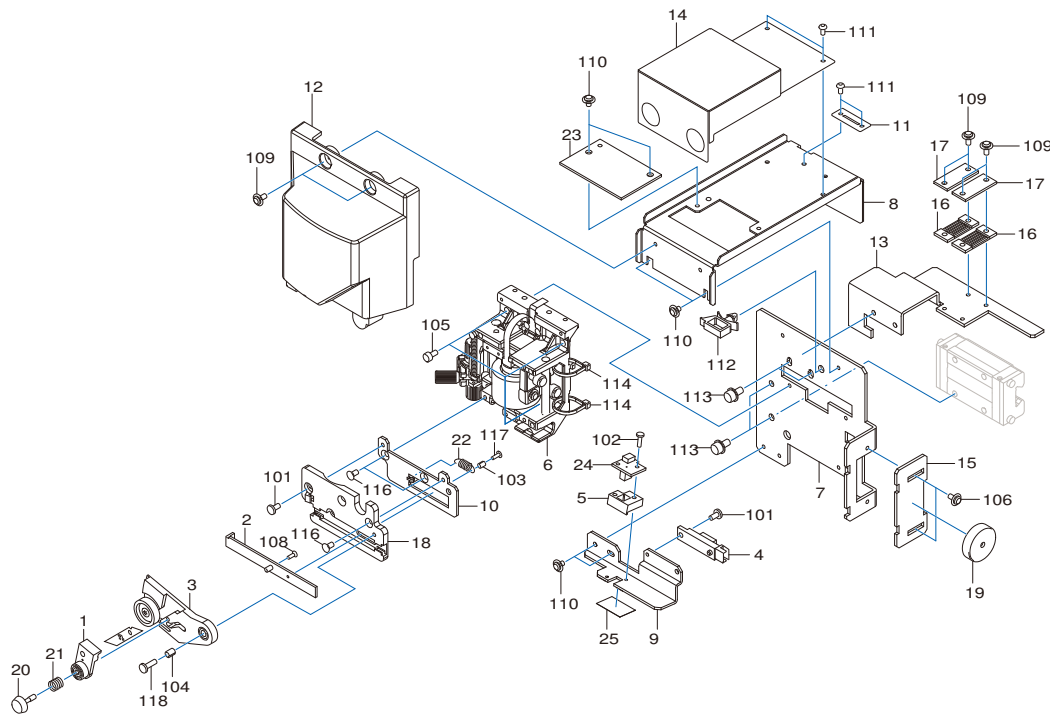

Pos	Code	Description
1	22805292	ASSY,CLAMP BLADE SV CM-500
2	22805287	ASSY,PLATE CAM SLIDE SV CM-500
3	22805291	ASSY,HOLDER BLADE SV CM-500
4	15099115	SENSOR-INTERRUPTER GP2A25NJ
5	1000012532	SPACER,CROP SENSOR GS-24
6	6000003920	ASSY,CUT TOOL T VG-640_02
6	6000004399	ASSY,CUT TOOL T VG-640_04
6	6703490530	ASSY,CUT TOOL T VG-640
7	1000015482	FRAME,CUT CARRIAGE SG-540
8	1000015483	STAY,CUT CARRIAGE BOARD SG-540
9	1000015487	STAY,PINCH SENSOR SG-540
10	1000015488	FRAME,CUTTER SG-540
11	1000015428	PLATE,CABLE SLIT SG-540
12	1000014433	COVER,CUT CARRIAGE VG-640
12	1000020806	COVER,CUT CARRIAGE CG2076
13	1000015486	STAY,HOLDER BELT SG-540
14	1000015484	COVER,CUT BOARD SG-540
15	1000015090	PLATE,ADJUSTER MAGNET VG-640
15	1000020032	PLATE,ADJUSTER MAGNET VG-640TH
16	1000015114	HOLDER,BELT EGX-600_01
16	21655232	HOLDER,BELT EGX-600
17	1000020055	COVER,BELT HOLDER EGX-600TH
17	22025646	COVER,BELT HOLDER EGX-600
18	22355656	BASE,CUTTER CM-500
19	1000011928	MAGNET,SMF-2144
20	21495115	SCREW,BLADE SET CM-500
21	1000012948	SPRING,SCREW CM-500
21	22175155	SPRING,SCREW CM-500
22	1000012947	SPRING,BLADE UP CM-500
22	22175154	SPRING,BLADE UP CM-500
23	W704220010	ASSY,CUT CARRIAGE SG-540
24	W704220030	ASSY,CROP SENSOR SG-540
25	1000015776	SHEET,FILTER CROP SG-540
25	1000016437	SHEET,FILTER CROP SG-540_01
101	31019116AS	SCREW SET,BINDING M3*6 3CBC 100 PCS
102	31019149	SCREW SET,BINDING M2.3*8 3CBC 100PCS
103	31029801AS	BUSH SET,ROLL 2*4 3C100PCS
104	31029803AS	BUSH SET,ROLL 3*5 3C 20PCS.
105	31049105AS	SCREW SET,CAP M3*6 3CBC 20 PCS
106	31089117	SCREW SET,PAN 3*6 NI+PW 100 PCS.

Pos	Code	Description
108	31169111	SCREW SET,FLAT M2*6 NI 100 PCS.
109	31289102AS	CUPSCREW SET,M3*6 NI 50 PCS.
110	31289109AS	CUPSCREW SET,M3*4 NI 100 PCS
111	31299102AS	RIVET SET,NYLON P2655B 20 PCS.
112	3000000560	SADDLE,LOCKING WIRE LWS-0711Z_TH
112	31409801AS	SADDLE,LOCKING WIRE LWS-0711Z 20P
113	3000000172	SCREW SET,CAP M4*8 NI WSH4*9*0.8 20P
114	31329601AS	CLAMP SET,INSULOK T-18S 100 PCS.
115	3000000259	WASHER SET,POM CC-0310-10 20PCS
116	31169103AS	SCREW SET,FLAT M3*6 3CBC 100 PCS
117	31229103AS	SCREW SET,TRUSS M2*6 NI 100 PCS
118	31019118AS	SCREW SET,BINDING M3*10 3CBC 100PCS

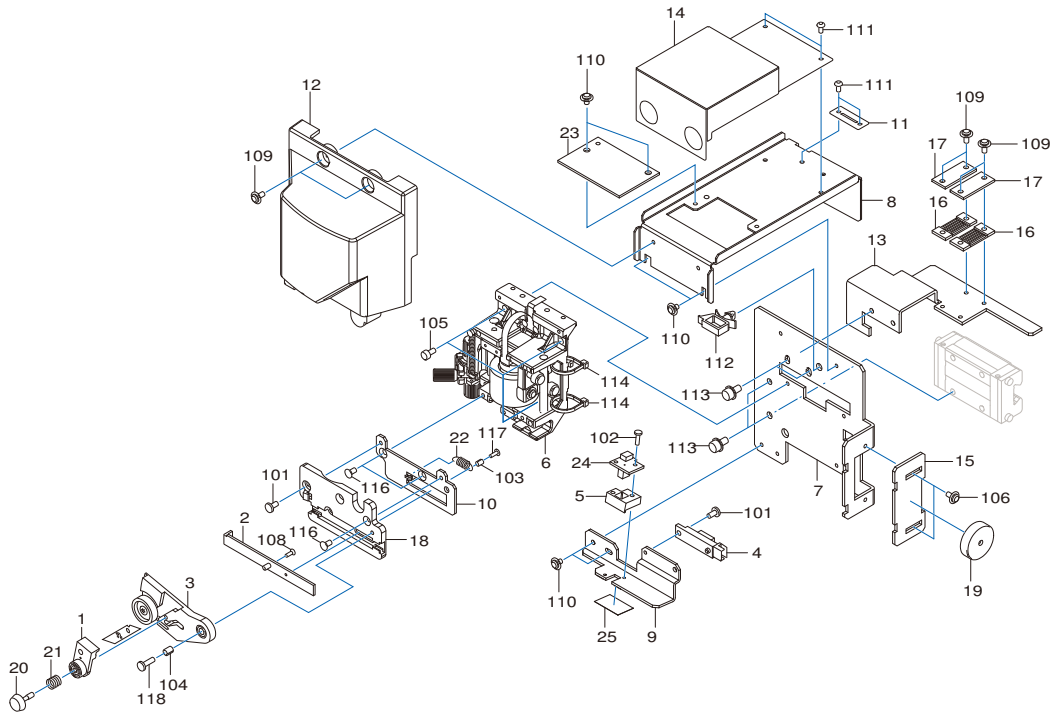

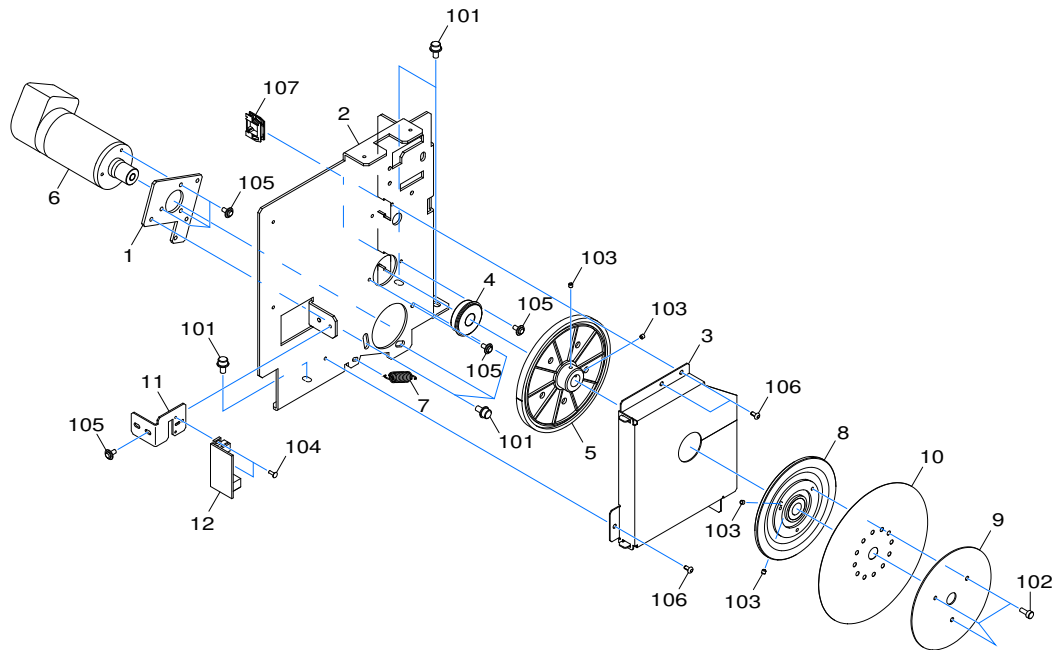

Pos	Code	Description
1	1000014906	FLANGE,MOTOR FEED VS-640I
2	1000015331	STAY,SUPPORT RAIL R SG-540
3	1000015332	COVER,FEED GEAR SG-540
4	1000006709	R-BEARING,6000ZZNR*NS7S
5	21685128	GEAR H300 S10(B6C16POM)
6	6000002694	ASSY,FEED MOTOR SG-540
7	22175157	SPRING,C P-ROLLER CM-500
8	1000002593	FLANGE,GRIT-ENCORDER VP-540
9	1000015595	STOPPER,GRIT-ENCORDER VP-540
10	1000015584	SHEET,ROTARY DISK SLIT 360LPI
11	1000014904	STAY,G-ENCODER SENSOR VP-540
12	W704220020	ASSY,GRIT ENCODER SG-540
101	3000000172	SCREW SET,CAP M4*8 NI WSH4*9*0.8 20P
102	31049170AS	SCREW SET,CAP M3*8 NI 50 PCS.
103	31199701AS	SCREW SET,SET WP M3*3 NI 20 PCS
104	31229103AS	SCREW SET,TRUSS M2*6 NI 100 PCS
105	31289102AS	CUPSCREW SET,M3*6 NI 50 PCS.
106	31299102AS	RIVET SET,NYLON P2655B 20 PCS.
107	31409702	SADDLE SET,LOCKING WIRE LES-1010 20P

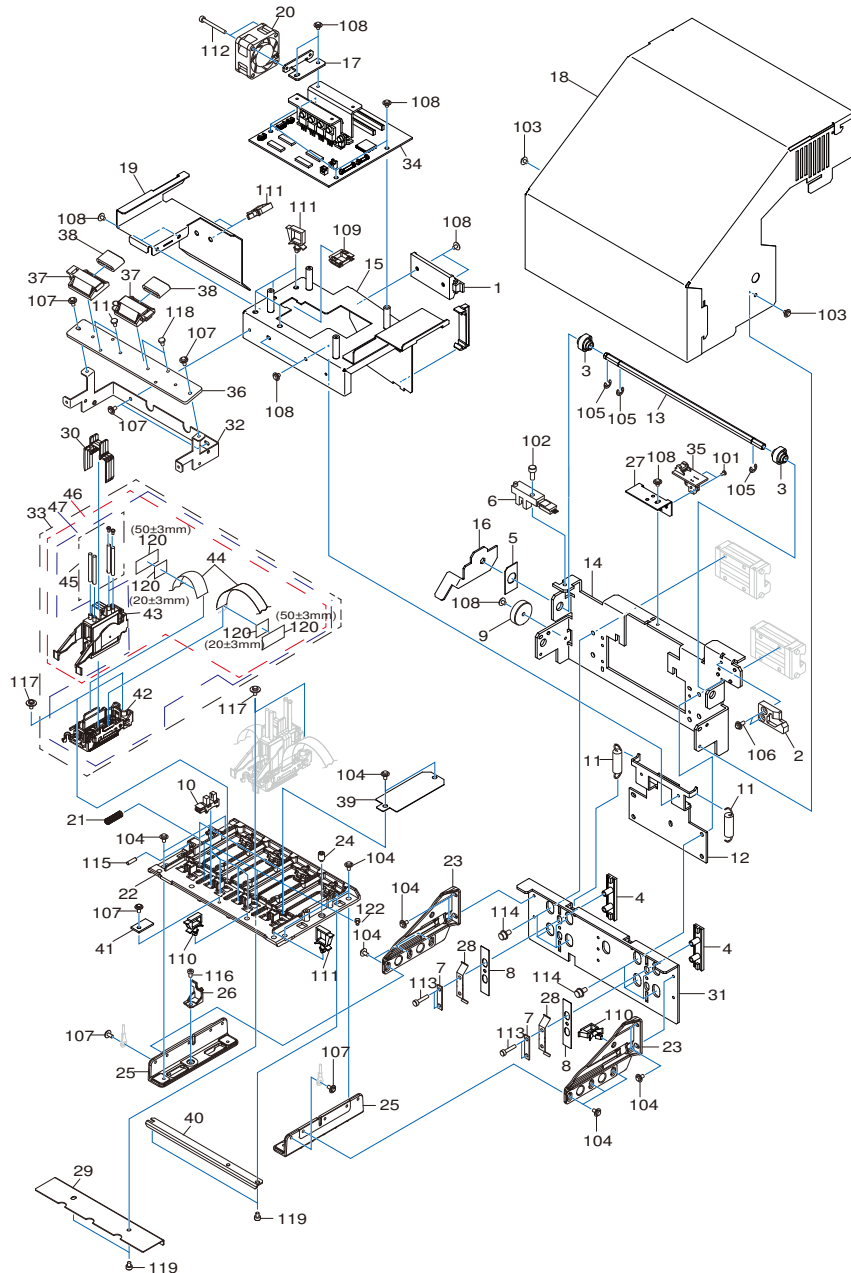

Pos	Code	Description
1	11769118	CLAMP,FCM2-S6-14
2	21345105	LOCK,CJ-500
3	1000015115	CAM,CARRIAGE FJ-540_02
4	1000015113	SLIDER,CARRIAGE FJ-540_02
5	1000014118	SPACER,U/D LEVER VP-540_01
6	1000006689	SENSOR-INTERRUPTER,EE-SX4009-P1
7	1000010186	SPACER,CARRIAGE SLIDE XF-640
7	1000020066	SPACER,CARRIAGE SLIDE XF-640TH
8	1000020067	PLATE,SLIDER CARRIAGE FJ-540TH
9	1000011928	MAGNET,SMF-2144
10	1000011069	SENSOR-INTERRUPTER,OJ-535S-A5
11	1000015808	SPRING,PULL CARRIAGE 5700 VG-640
11	1000020071	SPRING,PULL CARRIAGE 5700 VG-640TH
12	1000014213	SUPPORT,CARRIAGE BOARD EJ-640
12	1000020070	SUPPORT,CARRIAGE BOARD EJ-640TH
13	1000015476	SHAFT,HEXAGON CARRIAGE SG-540
14	1000015475	BASE,HOLDER CARRIAGE SG-540
15	1000015481	STAY,HOLDER CARRIAGE B SG-540
16	1000014347	LEVER,CARRIAGE VG-640
16	1000017234	LEVER,CARRIAGE VG-640 TH
17	1000015473	STAY,FAN CARRIAGE SG-540
18	1000015472	COVER,PRINT CARRIAGE SG-540
19	1000015474	STAY,CARRIAGE TUBE SG-540
20	1000018524	FAN,109P0424H642_80
21	1000015480	SPRING,CARRIAGE SIDE SG-540
22	1000016914	BASE,CARRIAGE ADC VG-640_01
22	1000018832	BASE,CARRIAGE ADC VG-640_02
23	1000014771	BASE,CARRIAGE SIDE ADC VG-640
24	1000015479	PIN,PIVOT SCREW SG-540
25	1000014773	STAY,CARRIAGE ADC VG-640
26	1000014774	BLOCK,ADJUST CARRIAGE VG-640
27	1000015477	PLATE,ENC SENS SG-540
28	1000014902	SPRING,CARRIAGE SIDE FJ-50
29	1000016915	COVER,CARRIAGE MIST VG-640_01
29	1000019102	COVER,CARRIAGE MIST VG-640_02
30	1000015045	GUARD,FFC HEAD VG-640
31	1000015046	FRAME,CARRIAGE U/D VG-640
31	1000020069	FRAME,CARRIAGE U/D VG-640TH
32	1000015271	STAY,IJ CARRIAGE FILTER VG-640_01
33	6000003077	ASSY,INKJET HEAD VG-640_01

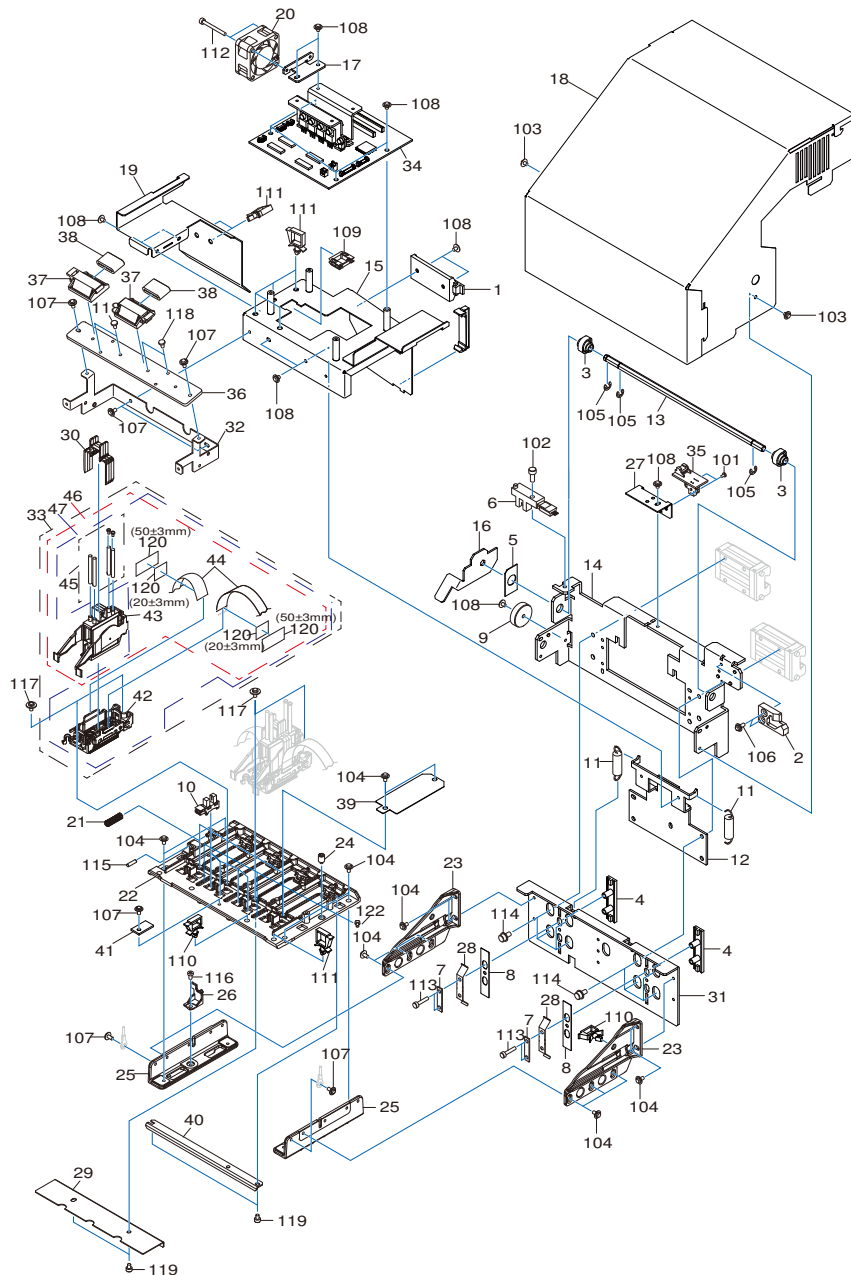

Pos	Code	Description
34	1000015535	ASSY,PRINT CARRIAGE BOARD SG-540
35	1000015533	ASSY,LINEAR ENCODER BOARD SG-540
36	1000015272	STAY,CARRIAGE FFC VG-640
36	1000017245	STAY,CARRIAGE FFC VG-640 TH
37	1000015261	CLAMP,FCM1-S6
38	1000015262	FILTER(E),FPCR17-9-0.5
39	1000015478	SHEET,HEAD COVER SG-540
40	1000016913	COVER,IJ HEAD REAR VG-640
41	1000015534	ASSY,THERMISTOR BOARD SG-540
42	6000003425	ASSY,INKJET HEAD (HEAD ONLY) SV CG2048
43	1000015256	ASSY,DAMPER DOUBLE CIR 2 VG-640
43	1000019701	ASSY,DAMPER DOUBLE CIR CG2075
44	1000014627	CABLE-CARD,24P0.5 200L BB HIGH-V
45	1000018253	HEAD TUBE 70MM+STOPPER SET SV CG2048
46	1000018350	HEAD CABLE-CARD 200L SET SV VG-640
47	6000003990	ASSY,INKJET HEAD 200L SV VG640
47	6000004769	ASSY,IJ HEAD SOL 200L SV VG-640
101	31019169	SCREW SET,BINDING M2*4 NI 100 PCS.
102	31049173AS	SCREW SET,CAP M4*10 NI 50 PCS.
103	31089110AS	SCREW SET,PAN M3*4 NI+PW 100 PCS
104	31089117	SCREW SET,PAN 3*6 NI+PW 100 PCS.
105	31149703AS	RING SET,E-RING ETW-4 100 PCS.
106	31239125AS	SCREW SET,W-SEMS M3*8 SUS 50 PCS.
107	31289102AS	CUPSCREW SET,M3*6 NI 50 PCS.
108	31289109AS	CUPSCREW SET,M3*4 NI 100 PCS
109	31409702	SADDLE SET,LOCKING WIRE LES-1010 20P
110	3000000560	SADDLE,LOCKING WIRE LWS-0711Z_TH
110	31409801AS	SADDLE,LOCKING WIRE LWS-0711Z 20P
111	31409811AS	SADDLE SET,LOCKING WIRE LWS-1211Z 20P
112	3000000465	CAP-SCREW,3*30 NI 100PCS
113	31799103	SCREW SET,CAP M3*15 NI 20PCS
114	3000000172	SCREW SET,CAP M4*8 NI WSH4*9*0.8 20P
115	3000000413	SET-SCREW,MARUSAKI_3_12_NI 20PCS
116	3000000414	LH-SCREW,CSHBTT-SUS-M3-5 20PCS
117	3000000415	NABE,3*6 NI WASHER D5 20PCS
118	3000000455	BIND,P-TIGHT 3*4 3C 20PCS.
119	31049119	SCREW SET,CAP M3*4 NI 20PCS.
120	3000000435	TAPE,650S-25-20X20
121	31289112AS	CUPSCREW SET,M3*10 NI 100 PCS.

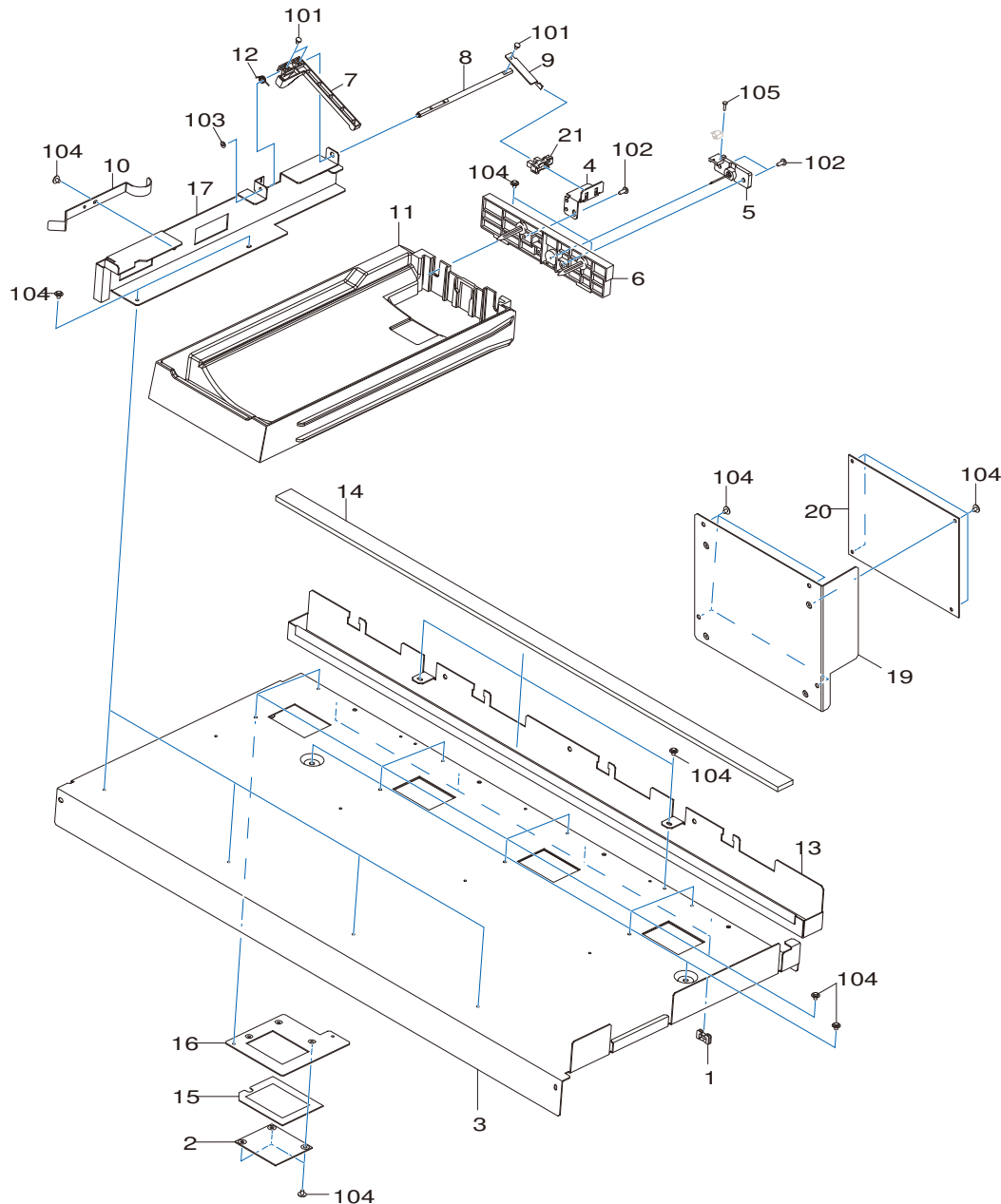

Pos	Code	Description
1	1000000196	SADDLE,LOCKING EDGE LES-0510
2	1000014128	RFID-MODULE,LXRFZZHAAA-022
3	1000017835	FRAME,HOLDER I/C SG-540_01
4	1000015444	STAY,INK EMPTY SENS SG-540
5	6000002739	ASSY,I/C NEEDLE HOLDER VG-640
6	1000014581	BASE, HOLDER NEEDLE VG-640
7	1000014582	LEVER,INK EMPTY VG-640
8	1000015442	SHAFT,INK EMPTY SG-540
9	1000015443	BLADE,INK EMPTY SG-540
10	1000014585	SPRING,PLATE I/C VG-640
11	1000014586	TRAY, INK POUCHES VG-640
12	1000014587	SPRING,LEVER INK EMPTY VG-640
13	1000015438	PLATE,INK HOLDER SG-540
14	1000014590	PAD,INK HOLDER VG-640
15	1000015032	PLATE,RFID VG-640
15	1000020031	PLATE,RFID VG-640TH
16	1000017221	PLATE,BASE RFID VG-640 TH
17	1000017836	FRAME,HOLDER SIDE I/C SG-540_01
19	1000015429	STAY,INKSYSTEM BOARD SG-540
20	1000015538	ASSY,INKSYSTEM RFID BOARD SG-540
21	1000011069	SENSOR-INTERRUPTER,OJ-535S-A5
101	31019148AS	SCREW SET,BINDING M2.6*4 NI 100 PCS
102	31019703	SCREW,BINDING P-TIGHT M3*8 3C 100P
103	31249952	WASHER SET,POLYSLIDER 2.6*5*.5 CUT 20PCS
104	31289109AS	CUPSCREW SET,M3*4 NI 100 PCS
105	3000000412	BIND,P-TIGHT 2*8 3C 20PCS.

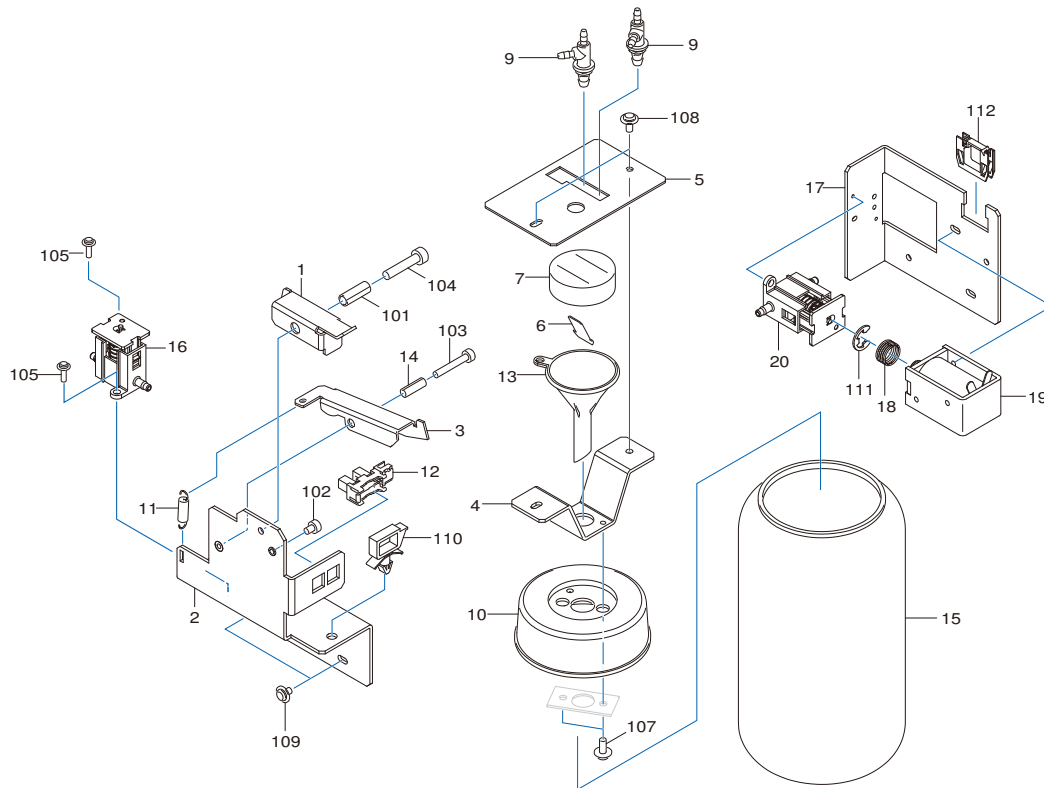

Pos	Code	Description
1	1000015445	KNOB,WASTE VALVE SG-540
2	1000016164	STAY,WASTE VALVE SG-540_01
3	1000015447	LEVER,WASTE VALVE SG-540
4	1000015430	HOLDER,WASTE TUBE SG-540
5	1000018316	HOLDER,FUNNEL VG-640_01
6	1000015741	STOPPER,TUBE FAI8 VG-640
6	1000020063	STOPPER,TUBE FAI8 VG-640TH
7	1000015742	PAD,INK FUNNEL ANTIFOAM VG-640
7	1000020062	PAD,INK FUNNEL ANTIFOAM VG-640TH
9	1000001577	ADAPTER,TUBE 2-4-T XC-540
10	7520501000	ASSY,CAP BOTTLE 2 FJ-52
11	22175122	SPRING,BACK UP PNC-960
12	1000011069	SENSOR-INTERRUPTER,OJ-535S-A5
13	1000014476	GUIDE,INK FUNNEL PE 6-316-01
14	3000000322	BUSH,ROLL 3*12.5 3C
15	11369115	CASE,PP BOTTLE
16	1000012701	VALVE,CHOKE XF-640
16	1000019097	VALVE,CHOKE CG2057
17	1000015455	BASE,CL VALVE SG-540
18	1000014140	SPRING,VALVE BIF-2
18	1000020061	SPRING,VALVE BIF-2TH
19	1000014297	SOLENOID,TDS-08A DC-24V TYPE2
19	1000018523	SOLENOID,TDS-08A DC-24V TYPE2
20	1000012701	VALVE,CHOKE XF-640
20	1000019097	VALVE,CHOKE CG2057
101	31029817	BUSH SET,ROLL 4*15 3C 20PCS
102	31049119	SCREW SET,CAP M3*4 NI 20PCS.
103	3000000464	CAP-SCREW,3*20 NI
103	31049172	SCREW SET,CAP M3*20 NI 20PCS
104	31049175AS	SCREW SET,CAP M4*20 NI 20 PCS.
105	31089121AS	SCREW SET,PAN M2.3*8 NI+PW 100PCS
107	31239125AS	SCREW SET,W-SEMS M3*8 SUS 50 PCS.
108	31289102AS	CUPSCREW SET,M3*6 NI 50 PCS.
109	31289109AS	CUPSCREW SET,M3*4 NI 100 PCS
110	3000000560	SADDLE,LOCKING WIRE LWS-0711Z_TH
110	31409801AS	SADDLE,LOCKING WIRE LWS-0711Z 20P
111	31149704AS	RING SET,E-RING ETW-6 SUS 100 PCS
112	31409702	SADDLE SET,LOCKING WIRE LES-1010 20P

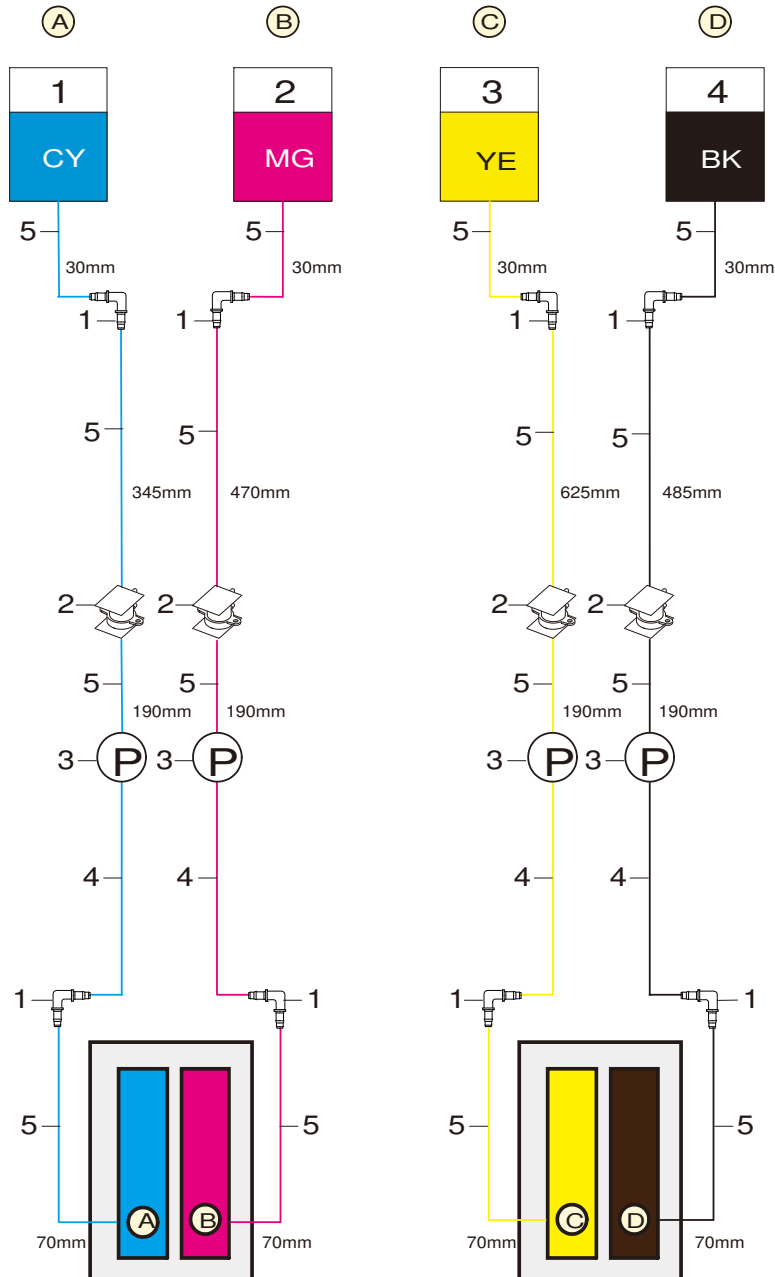

Pos	Code	Description
1	1000007124	ADAPTER,JOINT VPL306
1	1000017901	ADAPTER,JOINT 3L CG2023
2	1000014759	ASSY,VALVE VG-640
3	6000002334	ASSY,PRESS PUMP VG-640
4	1000015377	TUBE,PT01-RDG 3X3.8 LINK4 SG-540
4	1000016628	TUBE,PT05-RDG 3X3.8 LINK4 SG-540
4	1000017466	TUBE,PT05-RDG 3X3.8 LINK4 SG-540 TH
5	3000000504	TUBE,PT05-RDG 3X3.8 100M TH
5	6000002764	TUBE,CUT PT01-RDG 3X3.8 1500MM
5	6000003132	TUBE,CUT PT05-RDG 3X3.8 1500MM

Pos	Code	Description
1	3000000504	TUBE,PT05-RDG 3X3.8 100M TH
1	6000002764	TUBE,CUT PT01-RDG 3X3.8 1500MM
1	6000003132	TUBE,CUT PT05-RDG 3X3.8 1500MM
2	1000014965	TUBE,CUT SJ-RDG 2.2*3.2 500MM (MAX3)
2	3000000503	TUBE,SJ-RDG 2.2X3.2 100M TH
3	3000000422	TUBE,TM-15 6*8 50M
4	1000002123	TUBE,EPDM ID2-OD4 50MM
5	1000014829	ADAPTER,JOINT MCI-1
6	1000011924	ADAPTER,JUNCTION VPT-306
6	1000017902	ADAPTER,JUNCTION 3T CG2023
7	1000008314	ADAPTER,JOINT 2L MCL-1

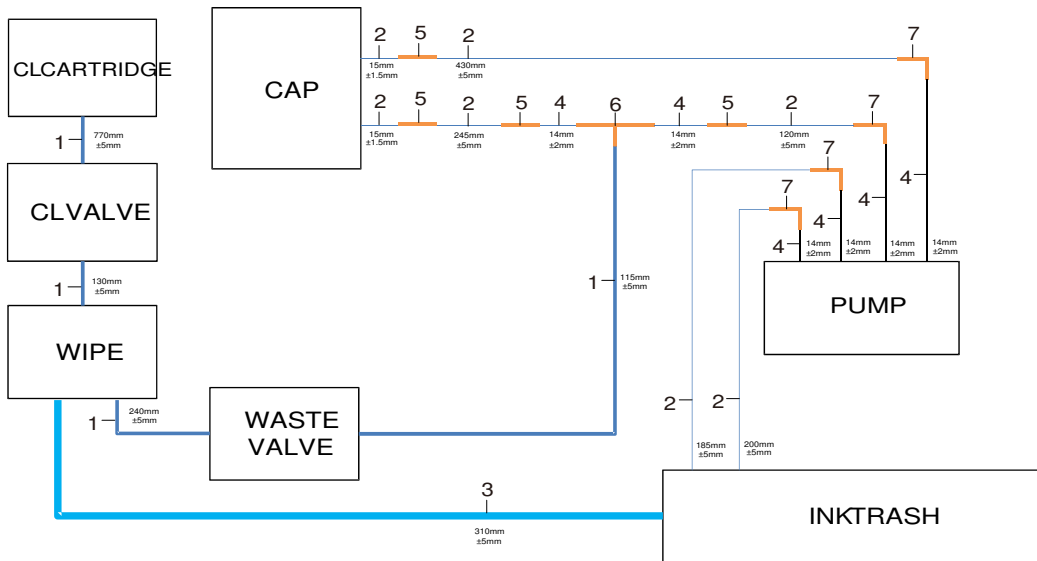

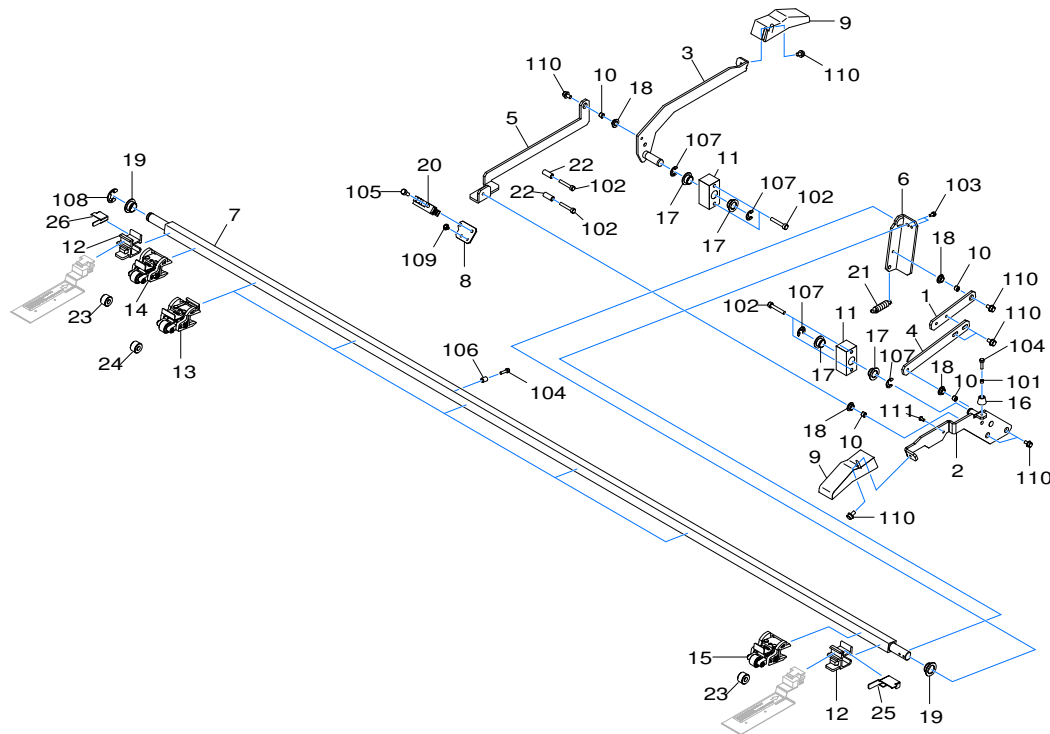

Pos	Code	Description
1	1000015384	STAY,LEVER ADJ SG-540
2	1000015385	LEVER,CAM PINCH FRONT SG-540
2	1000016836	LEVER,CAM PINCH FRONT SG-540_01
3	1000015386	LEVER,CAM PINCH REAR SG-540
3	1000016837	LEVER,CAM PINCH REAR SG-540_01
4	1000015387	STAY,LINK FRONT SG-540
4	1000016838	STAY,LINK FRONT SG-540_01
4	1000019032	STAY,LINK FRONT SG-540_03
5	1000015388	STAY,LINK REAR SG-540
6	1000015389	PLATE,LINK SUPPORT SG-540
6	1000016839	PLATE,LINK SUPPORT SG-540_01
7	1000015383	SHAFT,SQUARE SG-540
8	1000015390	STAY,PINCH SENS SG-540
9	1000014431	KNOB,VG-640
10	1000012953	COLLAR,LEVER FJ-540
11	22035196	STAND,LEVER SP-300
12	1000015110	ADAPTER,CLAMP MEDIA SP-500_01
12	21905192	ADAPTER,CLAMP MEDIA SP-540V
13	1000015672	ASSY,PINCHROLL C SG-540
13	6000003805	ASSY,PINCHROLL C CG2032
13	6000003806	ASSY,PINCHROLL C CG2048
13	6000005176	ASSY,PINCHROLL C VG-640
14	1000015671	ASSY,PINCHROLL L SG-540
14	6000005178	ASSY,PINCHROLL L VG-640
14	6700460210	ASSY,PINCHROLL L VP-540
15	1000015670	ASSY,PINCHROLL R SG-540
15	6000005177	ASSY,PINCHROLL R VG-640
15	6700460220	ASSY,PINCHROLL R VP-540
16	11879107	ABSORBER TK-12
17	1000018503	BUSH,80F-1006
17	12159563	BUSH,80F-1006
18	1000018512	BUSH,80F-0603
18	12159573	BUSH,80F-0603
19	1000018504	BUSH,SHAFT OILES 80F-1206
19	12159508	BUSH,SHAFT OILES 80F-1206
20	1000006689	SENSOR-INTERRUPTER,EE-SX4009-P1
21	1000012989	SPRING,PINCH PNC-1850
22	1000020065	COLLAR,P-ROLLER PNC-960TH
22	21745101	COLLAR,P-ROLLER PNC-960
23	21565102	P-ROLLER TD16S4(B10) TYPE2

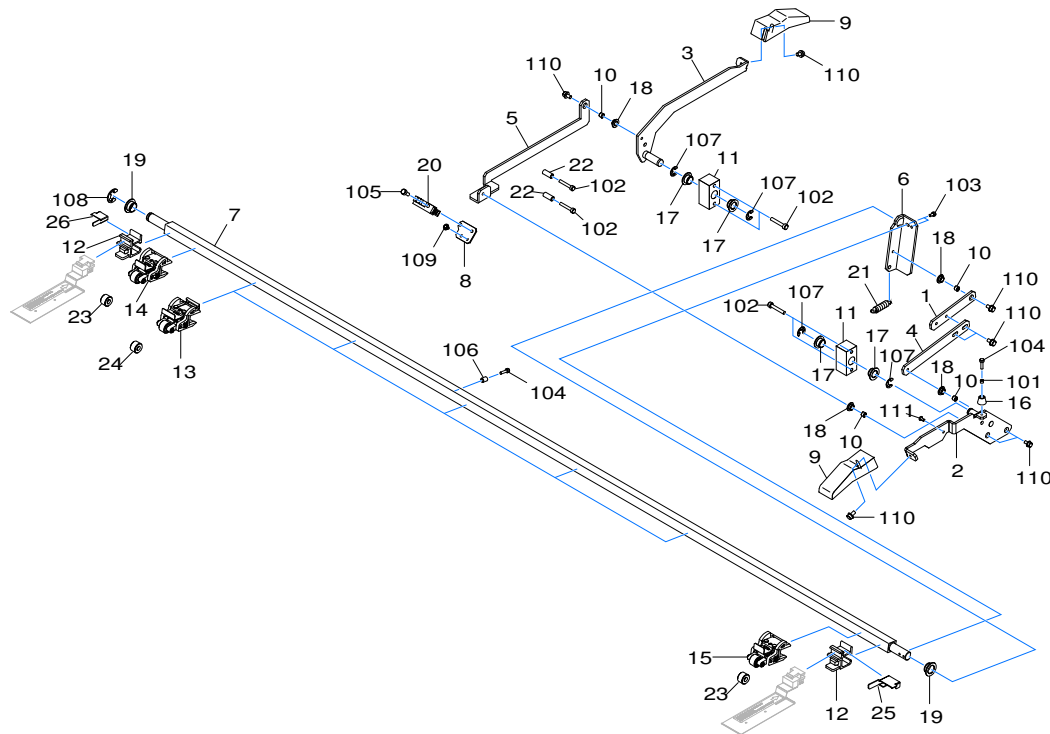

Pos	Code	Description
24	1000015305	P-ROLLER,FD16S4(B10) TYPE5
24	21565103	P-ROLLER FD16S4(B10) TYPE2
25	1000020262	SUPPORT,ADAPTER CLAMP R CG1115
26	1000020263	SUPPORT,ADAPTER CLAMP L CG1115
101	31029802AS	BUSH SET,ROLL 3*3.5 3C 100PCS.
102	3000000423	CAP-SCREW,4*25 3CBC 100PCS
102	31049137AS	SCREW SET,CAP M4*25 3CBC 20 PCS
103	31049142AS	SCREW SET,CAP M3*6 NI MEC 20 PCS
104	31049171AS	SCREW SET,CAP M3*12 NI 50 PCS.
105	31049173AS	SCREW SET,CAP M4*10 NI 50 PCS.
106	31129101	PIPE SET,POLYCA 3*6*8 20PCS
107	3000000558	RING,E ETW-7 SUS_TH
107	31149705	RING SET,E-RING ETW-7 SUS 50PCS
108	3000000559	RING,E ETW-10 SUS_TH
108	31149706AS	RING SET,E-RING ETW-10 SUS 20 PCS
109	31289102AS	CUPSCREW SET,M3*6 NI 50 PCS.
110	3000000172	SCREW SET,CAP M4*8 NI WSH4*9*0.8 20P
111	31159904	RIVET SET,NYLON P3065B 20 PCS.

Pos	Code	Description
1	1000014379	STAY,PANEL VG-640
1	1000015420	STAY,PANEL SG-540
1	1000019410	STAY,PANEL 2 SG-540
2	1000015421	SHEET,PANEL SG-540
3	1000015422	COVER,PANEL SG-540
4	1000014481	KEY, TOP BLACK VG-640
5	1000015536	ASSY,PANEL BOARD SG-540
6	12239406	CUSHION, TM-96-6
7	1000012564	KEY, TOP CLEAR GS-24
7	22495102	KEY TOP, CLEAR GX-24
101	31029820	BUSH SET, ROLL 3*2 3C 50PCS
102	31289102AS	CUPSCREW SET, M3*6 NI 50 PCS.
103	31289105AS	CUPSCREW SET, M3*6 3CBC 100 PCS

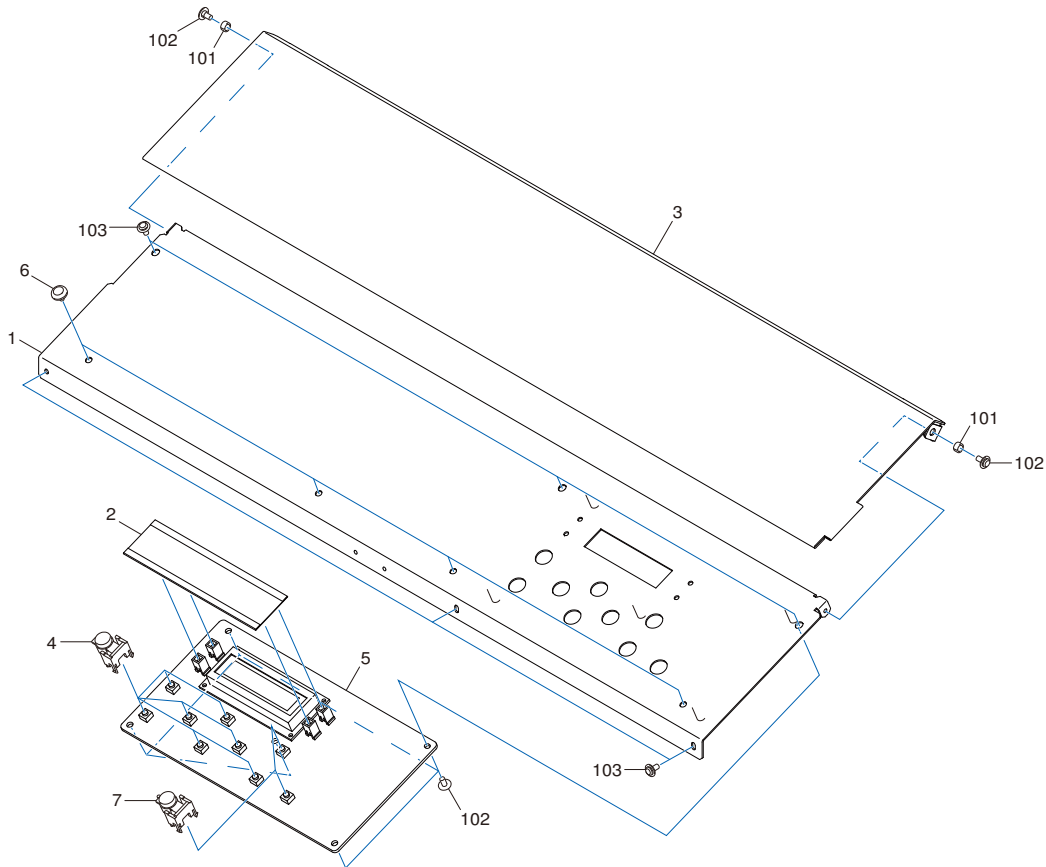

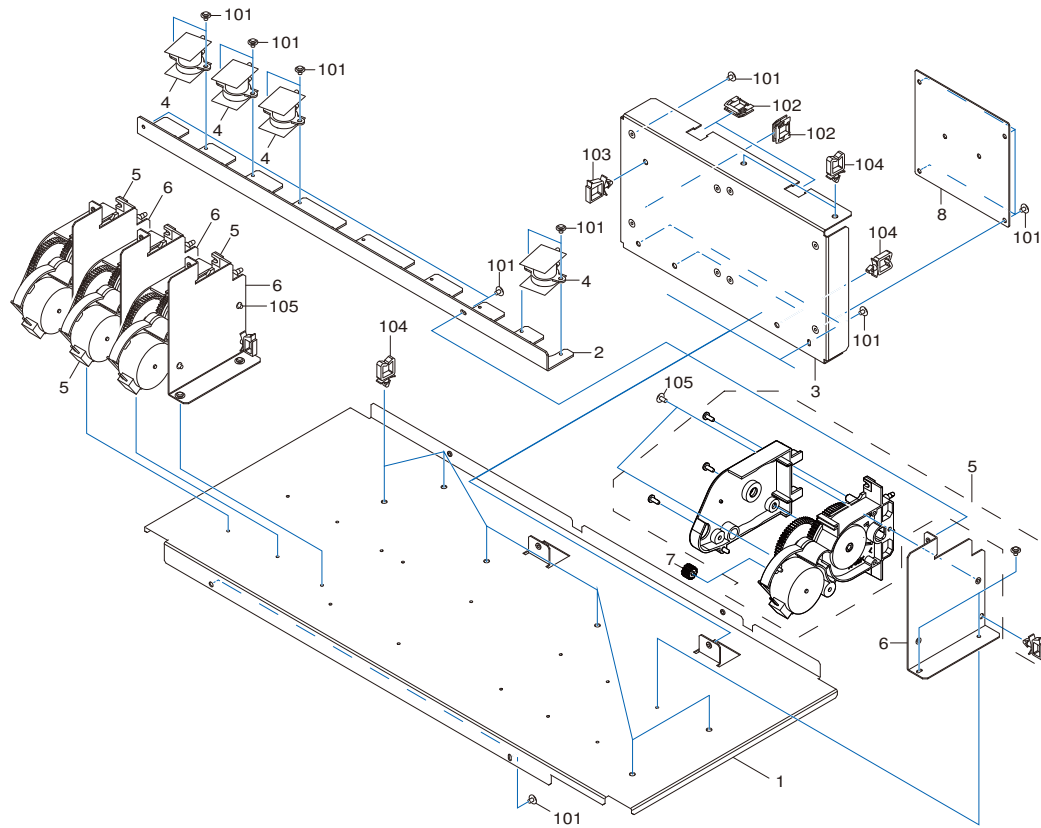

Pos	Code	Description
1	1000015468	PLATE,UNDER L SG-540
2	1000015469	BASE,CHECK VALVE SG-540
3	1000015470	STAY,PUMP BOARD SG-540
4	1000014759	ASSY,VALVE VG-640
5	6000002334	ASSY,PRESS PUMP VG-640
6	1000015471	STAY,PRESS PUMP SG-540
7	1000015179	GEAR,S12S3BS VG-640
8	1000015539	ASSY,PUMP DRIVE BOARD 0.6A*4 SG-540
101	31289109AS	CUPSCREW SET,M3*4 NI 100 PCS
102	31409702	SADDLE SET,LOCKING WIRE LES-1010 20P
103	31409811AS	SADDLE SET,LOCKING WIRE LWS-1211Z 20P
104	3000000216	SADDLE,WIRE WS-2N-V0
105	31289102AS	CUPSCREW SET,M3*6 NI 50 PCS.
106	3000000560	SADDLE,LOCKING WIRE LWS-0711Z_TH
106	31409801AS	SADDLE,LOCKING WIRE LWS-0711Z 20P
107	31019703	SCREW,BINDING P-TIGHT M3*8 3C 100P

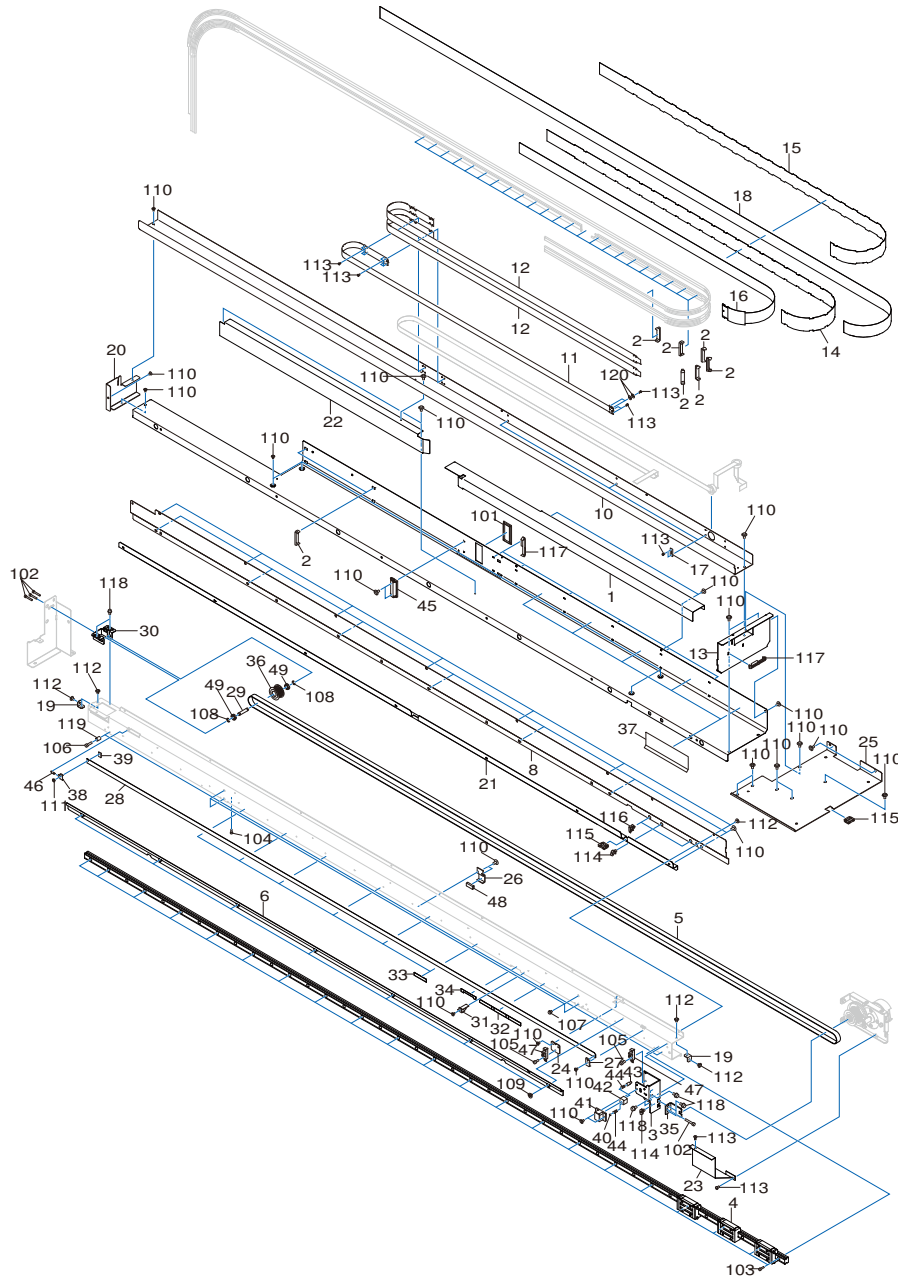

Pos	Code	Description
1	1000015370	SUPPORT,CUT CABLE SG-540
2	1000015378	GUIDE,TUBE SG-540
3	1000015351	STAY,LOCK SG-540
4	1000015357	L-BEARING,SSR15XW1GGC1E/2GC1E+2320L
5	1000015650	BELT,150S2M2459LW-C
6	1000015359	RAIL,LINEAR SCALE SG-540
8	1000015361	PLATE,RAIL REAR SG-540
9	1000015365	FRAME,SUPPORT RAIL SG-540
10	1000015366	GUIDE,CUT CABLE SG-540
11	1000015658	PLATE,CUT CABLE VG-540
12	1000015380	SHEET,CUT CABLE SG-540
13	1000015367	COVER,RAIL SIDE R SG-540
14	1000015372	HOLDER,CABLE F SG-540
15	1000015373	HOLDER,CABLE SG-540
16	1000015647	PLATE,HOLDER CABLE VG-540
17	1000015428	PLATE,CABLE SLIT SG-540
18	1000015376	SHEET,HOLDER CABLE SG-540
19	1000015362	STAY,RAIL GUIDE SG-540
20	1000015369	COVER,RAIL SIDE L SG-540
21	1000015363	STAY,RAIL UNDER SG-540
22	1000015371	SUPPORT,GUIDE CABLE SG-540
23	1000015353	COVER,SCAN MOTOR SG-540
24	1000015364	PLATE,CUT ORIGIN SG-540
25	1000015354	SUPPORT,SCAN MOTOR SG-540
26	1000015596	HOLDER,BACKUP SHAFTSQUARE RE-640
27	22135441	STOPPER,LINEAR SCALE FJ-540
28	1000003665	SHEET,LINEAR SCALE XJ-540
29	1000012957	SHAFT,IDLE PULLEY XC-540
30	1000001555	HOLDER,IDLE PULLEY XC-540
31	1000012965	STAY,HOLD SHAFT SQUARE SP-500
32	1000002971	LABEL,G-ROLLER 170 VP-540 #LA978
33	1000002970	LABEL,G-ROLLER 50 VP-540 #LA977
34	1000002685	LABEL,PINCH ROLL VP-540#LA968
35	1000002534	STAY,SHAFT DRIVE PULLEY VP-540
35	1000020056	STAY,SHAFT DRIVE PULLEY VP-540TH
36	1000001904	PULLEY,T55P2S16(B21C26)
37	1000012983	SHEET,FRAME SUPPORT RAIL VP-540
38	1000012985	HOLDER,LINEAR SCALE CJ-70
39	22055316	PLATE,LINEAR SCALE CJ-70
40	11869103	BALL,4MM

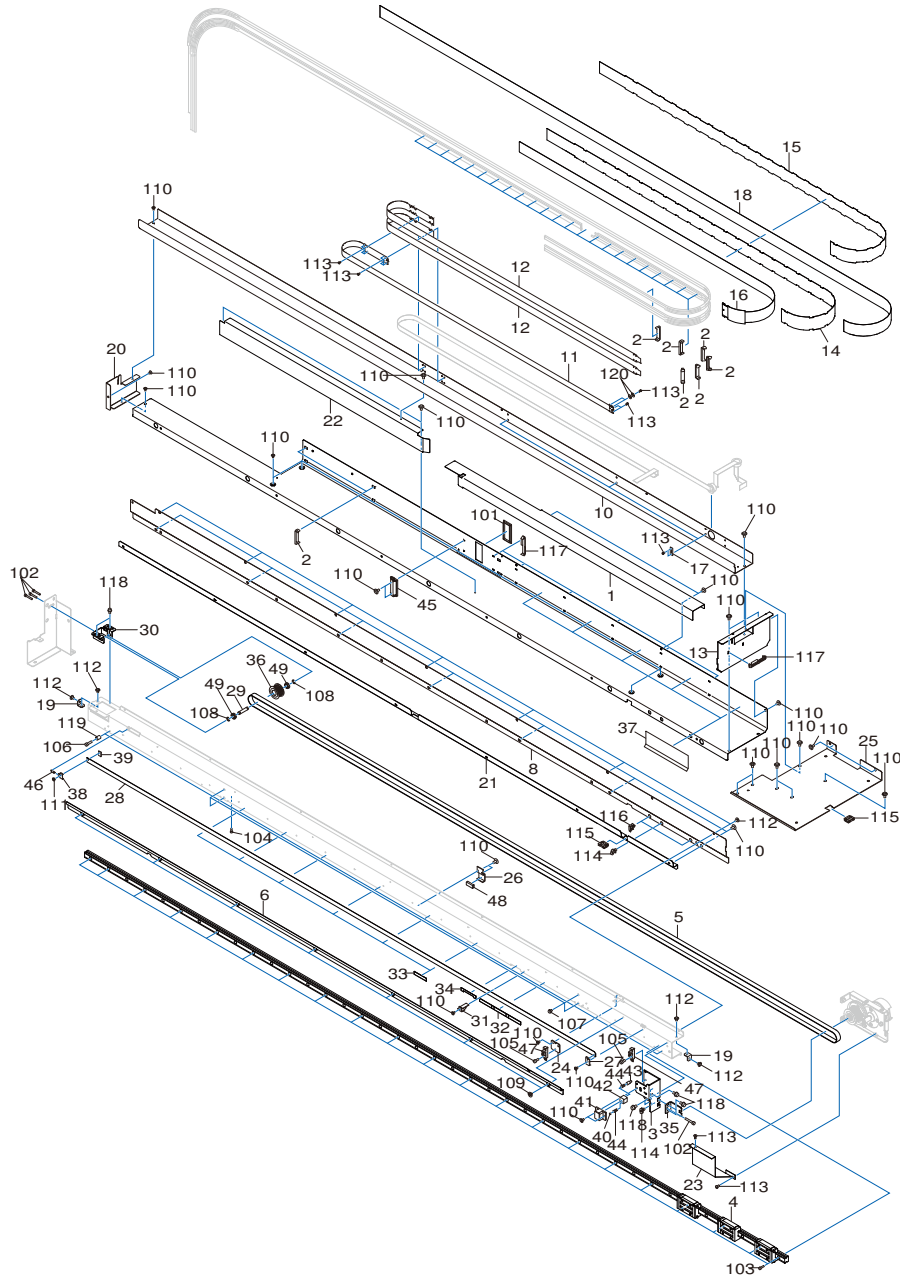

Pos	Code	Description
41	1000016171	CASE,LOCK CJ-70_02
41	21365103	CASE,LOCK CJ-70
42	1000016170	SLIDER,LOCK CJ-70_02
42	22185101	SLIDER,LOCK CJ-70
43	1000012944	SHAFT,LOCK CJ-70
44	22175134	SPRING,A CJ-70
45	11769118	CLAMP,FCM2-S6-14
46	22175122	SPRING,BACK UP PNC-960
47	1000006689	SENSOR-INTERRUPTER,EE-SX4009-P1
48	1000015267	GASKET,STGH 5-8 L=20MM
49	22175815	BEARING F8-16ZZ
101	31029106	BUSH,SQUARE SB-6025
102	3000000423	CAP-SCREW,4*25 3CBC 100PCS
102	31049137AS	SCREW SET,CAP M4*25 3CBC 20 PCS
103	31049155AS	SCREW SET,CAP M3*12 BC+PW 20 PCS.
104	31049170AS	SCREW SET,CAP M3*8 NI 50 PCS.
105	31049173AS	SCREW SET,CAP M4*10 NI 50 PCS.
106	31049174AS	SCREW SET,CAP M4*15 NI 20 PCS.
107	31069104	SCREW,CAP M4*6+FL NI
108	31149704AS	RING SET,E-RING ETW-6 SUS 100 PCS
109	31239103AS	SCREW SET,W-SEMS M3*8 NI+PW 50 PCS
110	31289102AS	CUPSCREW SET,M3*6 NI 50 PCS.
111	31289109AS	CUPSCREW SET,M3*4 NI 100 PCS
112	31289111AS	CUPSCREW SET, M4*6 NI 100 PCS.
113	31299102AS	RIVET SET,NYLON P2655B 20 PCS.
114	31329501AS	CLAMP SET,PUSH MOUNT RT30SSF5 20P
115	31409702	SADDLE SET,LOCKING WIRE LES-1010 20P
116	3000000560	SADDLE,LOCKING WIRE LWS-0711Z_TH
116	31409801AS	SADDLE,LOCKING WIRE LWS-0711Z 20P
117	3000000033	CLAMP,WIRE PLESS RFC-45VO
118	3000000172	SCREW SET,CAP M4*8 NI WSH4*9*0.8 20P
119	31129102	PIPE SET,POLYCA 4*8*10 20PCS
120	3000000259	WASHER SET,POM CC-0310-10 20PCS

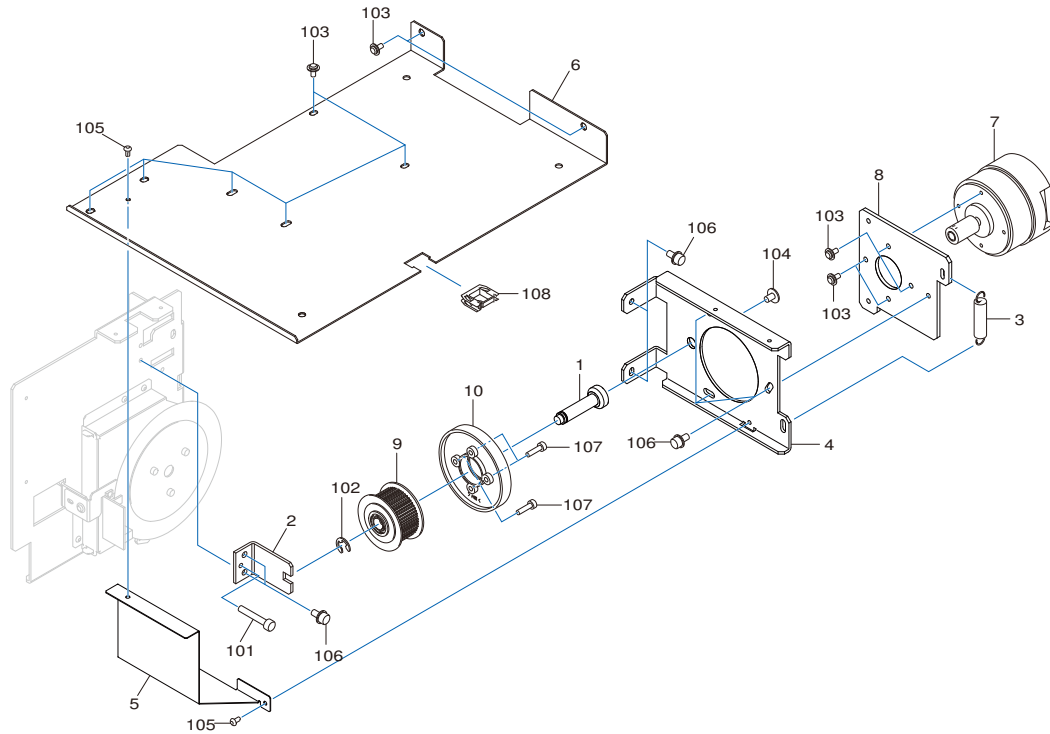

Pos	Code	Description
1	1000012807	SHAFT,DRIVE PULLEY XC-540
2	1000002534	STAY,SHAFT DRIVE PULLEY VP-540
2	1000020056	STAY,SHAFT DRIVE PULLEY VP-540TH
3	22175157	SPRING,C P-ROLLER CM-500
4	1000015352	BASE,SCAN DRIVE SG-540
5	1000015353	COVER,SCAN MOTOR SG-540
6	1000015354	SUPPORT,SCAN MOTOR SG-540
7	6000002333	ASSY,SCAN MOTOR SV VG-640
8	1000015356	FLANGE,MOTOR SCAN SG-540
9	6700469030	ASSY,PULLEY VP-540
10	1000001905	GEAR,H187S20(B8)
101	3000000423	CAP-SCREW,4*25 3CBC 100PCS
101	31049137AS	SCREW SET,CAP M4*25 3CBC 20 PCS
102	31149704AS	RING SET,E-RING ETW-6 SUS 100 PCS
103	31289102AS	CUPSCREW SET,M3*6 NI 50 PCS.
104	31289111AS	CUPSCREW SET, M4*6 NI 100 PCS.
105	31299102AS	RIVET SET,NYLON P2655B 20 PCS.
106	3000000172	SCREW SET,CAP M4*8 NI WSH4*9*0.8 20P
107	31049171AS	SCREW SET,CAP M3*12 NI 50 PCS.
108	31409702	SADDLE SET,LOCKING WIRE LES-1010 20P

Pos	Code	Description
1	ST-056	TORQUE DRIVER N6
2	1000015274	BIT,PHILLIPS NO.2 L200MM
3	ST-001	TENSION GAUGE 2000GF/2000CN
4	1000003138	SET,CLEANER STICK TX712A 10PCS.
4	1000007172	CLEANER SET,STICK TX712A 100PCS
4	ST-037	CLEAN STICK TX712A
5	21755107	CLEANING LIQUID(SL) 500ML
5	6702419050	CLEANING LIQUID(ESL5) 500ML
6	22085118	KIT,CLEANING(SL)
6	6701409310	KIT,CLEANING(ESL5) 100ML
7	21675102	GREASE,FLOIL G-902 10ML
7	6000004129	GREASE,FLOIL G-902 10ML_02

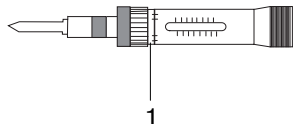

1

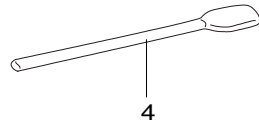

4

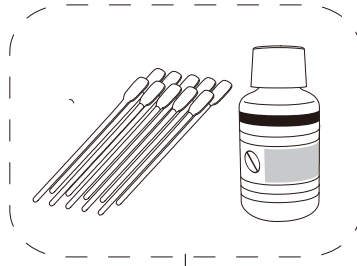

6

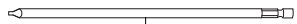

2



3



5

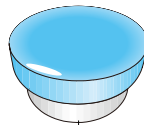

7

Pos	Code	Description
1	1000015330	STAY,STAND SG-540
2	6000002177	ASSY,FEEDER HOUSING L
2	6000003537	ASSY,FEEDER HOUSING L SV VG-640 T
3	6000002180	ASSY,FEEDER HOUSING R
3	6000003538	ASSY,FEEDER HOUSING R SV VG-640 T
4	1000015325	ASSY,BASE STAND SG-540
5	1000015326	ASSY,STAND LEG R SG-540
6	1000014749	ASSY,STAND LEG L VG-640
6	1000015327	ASSY,STAND LEG L SG-540
6	1000016207	ASSY,STAND LEG L VG-540TH
7	1000015328	ARM,R FEEDER SG-540
8	1000015329	ARM,L FEEDER SG-540
9	1000015601	PIPE,FEEDER SHAFT RS-540
10	1000003635	STOPPER,PIPE FEEDER XJ-740
11	1000003892	CASTER,STAND XJ-740
12	1000014294	KNOB,KG-B1 M6X30
101	31049157	SCREW,CAP M6*20 3CBC+PW+SW
102	31049169AS	SCREW SET,CAP M4*8 3CBC+PW 20PCS
103	31249220AS	WASHER SET,PLAIN 6.5*16*1 NI 100PCS

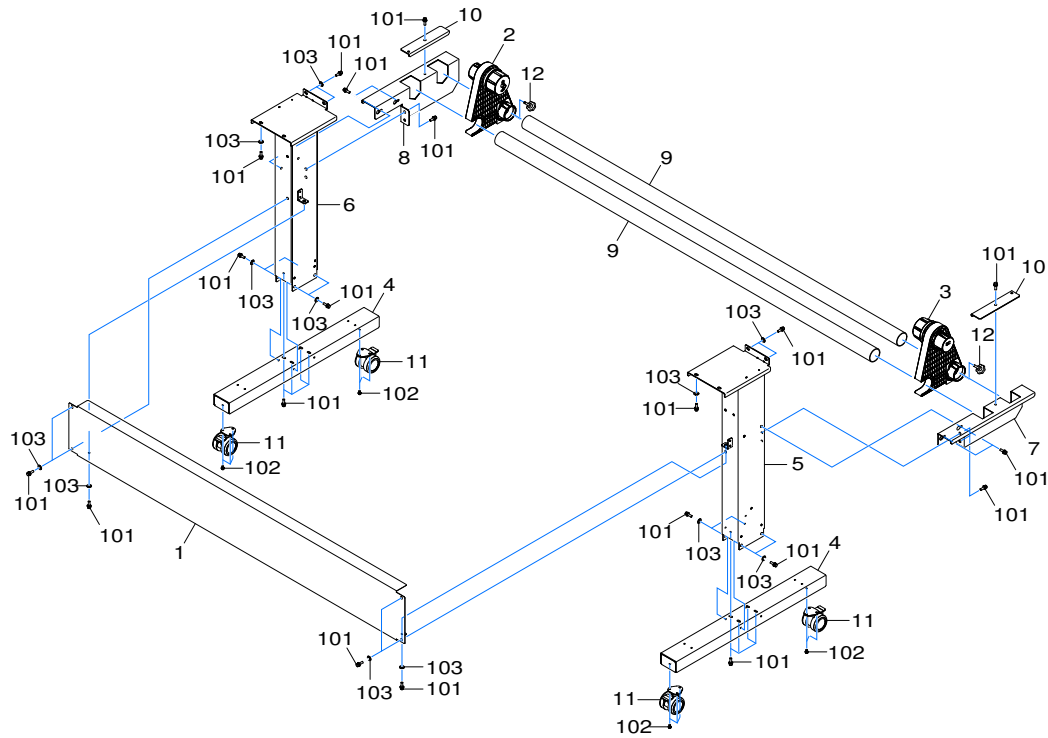

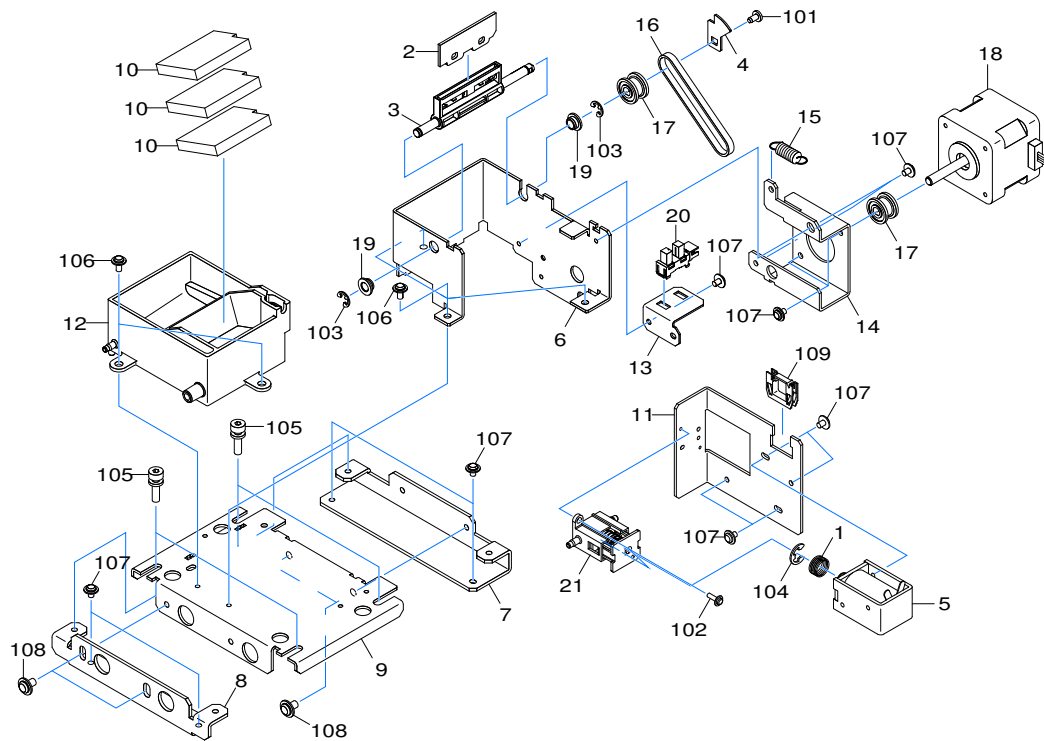

Pos	Code	Description
1	1000014140	SPRING,VALVE BIF-2
1	1000020061	SPRING,VALVE BIF-2TH
2	1000014754	WIPER,HEAD VG-640
3	1000014755	HOLDER,WIPER 2 VG-640
4	1000015450	PLATE,WIPER SENSOR SG-540
5	1000014297	SOLENOID,TDS-08A DC-24V TYPE2
5	1000018523	SOLENOID,TDS-08A DC-24V TYPE2
6	1000015448	FRAME,WIPER SG-540
7	1000015454	STAY,ADJUSTER R WIPE SG-540
8	1000015453	STAY,ADJUSTER F WIPE SG-540
9	1000015452	FRAME,BASE WIPE SG-540
9	1000016841	FRAME,BASE WIPER SG-540_01
10	1000014464	PAD,CLEANER D VG-640
10	1000020059	PAD,CLEANER D VG-640TH
11	1000015455	BASE,CL VALVE SG-540
12	1000014466	TRAY,LIQUID WIPER VG-640
12	1000019760	TRAY,LIQUID WIPER CG2076
13	1000015449	STAY,WIPER SENSOR SG-540
14	1000015451	HOLDER,WIPER MOTOR SG-540
15	1000015186	SPRING,PINCH 930 FJ-540
16	1000005794	BELT,146P2M4-530
17	22565406	DRIVE PULLEY
18	1000018516	MOTOR,103-593-1041
18	22435106	MOTOR,103-593-1041
19	1000000796	BUSH,80F-0503
19	1000018501	BUSH,80F-0503
20	1000011069	SENSOR-INTERRUPTER,OJ-535S-A5
21	1000012701	VALVE,CHOKE XF-640
21	1000019097	VALVE,CHOKE CG2057
101	31019702AS	SCREW SET,BIND P-TIGHT M3*6 3C 100P
102	31089121AS	SCREW SET,PAN M2.3*8 NI+PW 100PCS
103	31149703AS	RING SET,E-RING ETW-4 100 PCS.
104	31149704AS	RING SET,E-RING ETW-6 SUS 100 PCS
105	31179106	SCREW,JACK UP SP-540V
106	31289102AS	CUPSCREW SET,M3*6 NI 50 PCS.
107	31289109AS	CUPSCREW SET,M3*4 NI 100 PCS
108	31289111AS	CUPSCREW SET, M4*6 NI 100 PCS.
109	31409702	SADDLE SET,LOCKING WIRE LES-1010 20P

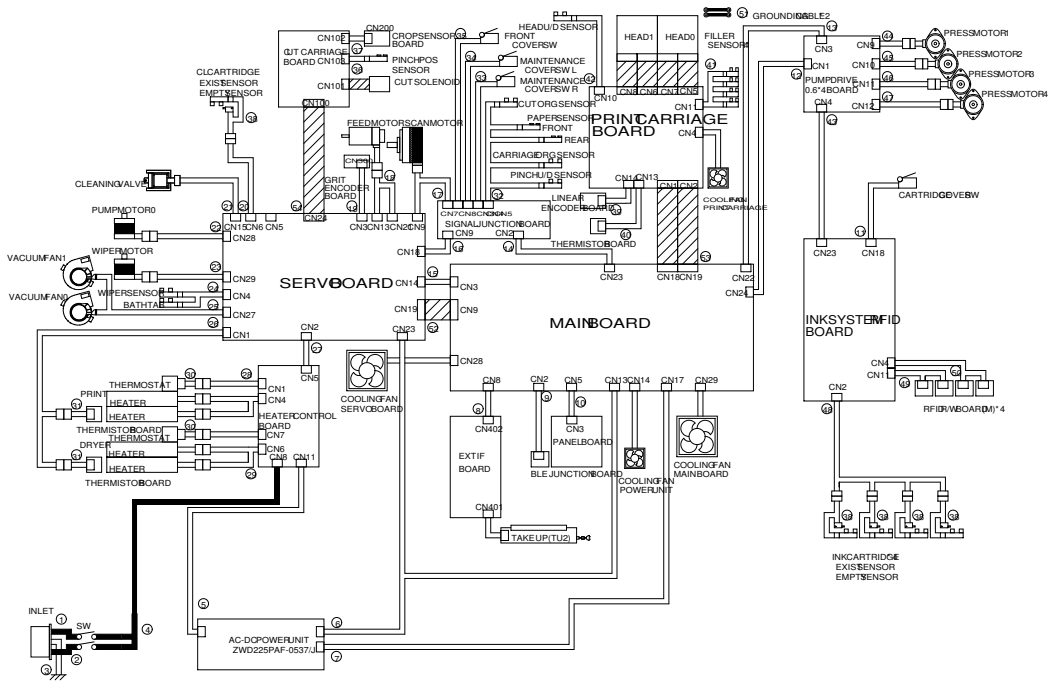

Pos	Code	Description
1	1000015606	CABLE-ASSY,JUNBI A SG-540
2	1000015607	CABLE-ASSY,JUNBI B SG-540
3	1000018826	CABLE-ASSY,JUNBI G SJ-1000 T
3	23415257	CABLE-ASSY,JUNBI G SJ-1000
4	1000015541	CABLE-ASSY,POWER AC-HCB SG-540
4	1000018862	CABLE-ASSY,POWER AC-HCB SG-540 T
5	1000015542	CABLE-ASSY,POWER HCB-PM SG-540
5	1000018863	CABLE-ASSY,POWER HCB-PM SG-540 T
6	1000015543	CABLE-ASSY,POWER DC SG-540
7	1000015565	CABLE-ASSY,ENESTAR SG-540
7	1000018877	CABLE-ASSY,ENESTAR SG-540 T
8	1000015544	CABLE-ASSY,EXT IF TU SG-540
8	1000018864	CABLE-ASSY,EXT IF TU SG-540 T
9	1000015564	CABLE-ASSY,BLUETOOTH SG-540
9	1000018876	CABLE-ASSY,BLUETOOTH SG-540 T
10	1000015566	CABLE-ASSY,PANEL SG-540
11	1000015567	CABLE-ASSY,INKTANK SW SG-540
11	1000018878	CABLE-ASSY,INKTANK SW SG-540 T
12	1000015574	CABLE-ASSY,F-SENS M-P SG-540
12	1000018879	CABLE-ASSY,F-SENS M-P SG-540 T
13	1000015575	CABLE-ASSY,M-P CAN SG-540
13	1000018880	CABLE-ASSY,M-P CAN SG-540 T
14	1000015557	CABLE-ASSY,SIGNAL JUNC SG-540
15	1000015558	CABLE-ASSY,SERVO UART SG-540
16	1000015555	CABLE-ASSY,SCAN MOTOR 2 SG-540
16	1000018870	CABLE-ASSY,SCAN MOTOR 2 SG-540 T
17	1000015556	CABLE-ASSY,SCAN MOTOR 1 SG-540
17	1000018871	CABLE-ASSY,SCAN MOTOR 1 SG-540 T
18	1000015554	CABLE-ASSY,FEED MOTOR SG-540
18	1000018869	CABLE-ASSY,FEED MOTOR SG-540 T
19	1000015553	CABLE-ASSY,GRIT ENC SG-540
19	1000018885	CABLE-ASSY,GRIT ENC SG-540 T
20	1000015563	CABLE-ASSY,CARTRIDGE LED SG-540
20	1000018875	CABLE-ASSY,CARTRIDGE LED SG-540 T
21	1000015562	CABLE-ASSY,CLEANING VALVE SG-540
21	1000018874	CABLE-ASSY,CLEANING VALVE SG-540 T
22	1000015552	CABLE-ASSY,PUMP MTR SG-540
23	1000015551	CABLE-ASSY,WIPER MTR SG-540
23	1000018868	CABLE-ASSY,WIPER MTR SG-540 T
24	1000015550	CABLE-ASSY,WIPER SENS SG-540

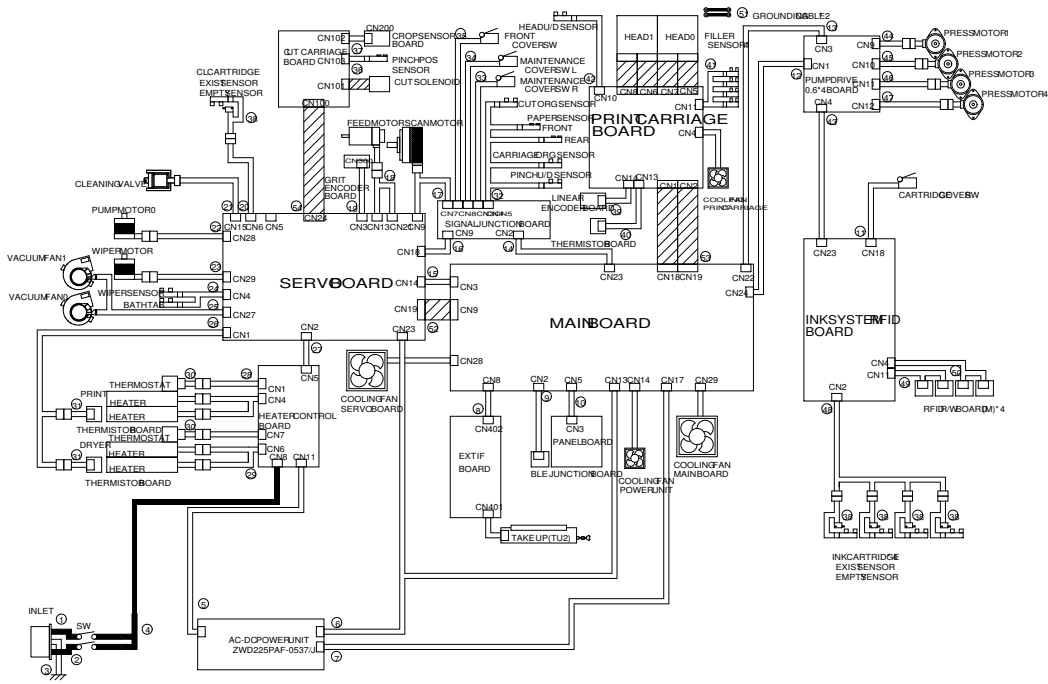

Pos	Code	Description
24	1000018867	CABLE-ASSY,WIPER SENS SG-540 T
25	1000015571	CABLE-ASSY,FAN JUNC SG-540
26	1000015549	CABLE-ASSY,TH JUNC SG-540
26	1000018866	CABLE-ASSY,TH JUNC SG-540 T
27	1000015546	CABLE-ASSY,HEATER CTL SG-540
27	1000018865	CABLE-ASSY,HEATER CTL SG-540 T
28	1000015789	CABLE-ASSY,HEATER PRINT SG-540
28	1000018883	CABLE-ASSY,HEATER PRINT SG-540 T
29	1000015790	CABLE-ASSY,HEATER APRON SG-540
29	1000018884	CABLE-ASSY,HEATER APRON SG-540 T
30	1000015608	CABLE-ASSY,THERMOSTAT SG-540
31	1000014097	CABLE-ASSY,THERMISTOR EJ-640
31	1000017237	CABLE-ASSY,THERMISTOR EJ-640 TH
32	1000015559	CABLE-ASSY,SENSORS SG-540
33	1000015560	CABLE-ASSY,R-COVER SW SG-540
33	1000018872	CABLE-ASSY,R-COVER SW SG-540 T
34	1000015573	CABLE-ASSY,L-COVER SW SG-540
35	1000015572	CABLE-ASSY,F-COVER SW SG-540
36	1000014571	CABLE-ASSY,P-POS SENS VG-640
37	1000014542	CABLE-ASSY,CROP SENS VG-640
38	1000014557	CABLE-ASSY,CARTRIDGE UNIT VG-640
38	1000018849	CABLE-ASSY,CARTRIDGE UNIT VG-640 T
39	1000015609	4CABLE-ASSY,L-ENCODER SG-540
40	1000014552	CABLE-ASSY,CARRIAGE TH VG-640
41	1000015610	CABLE-ASSY,FILLER SENS 2 SG-540
42	1000014528	CABLE-ASSY,H-UD SENS VG-640
43	1000015561	CABLE-ASSY,P-R CAN SG-540
43	1000018873	CABLE-ASSY,P-R CAN SG-540 T
44	1000014512	CABLE-ASSY,PRESS PUMP 1 VG-640
44	1000017238	CABLE-ASSY,PRESS PUMP 1 VG-640 TH
45	1000014513	CABLE-ASSY,PRESS PUMP 2 VG-640
45	1000017239	CABLE-ASSY,PRESS PUMP 2 VG-640 TH
46	1000014514	CABLE-ASSY,PRESS PUMP 3 VG-640
46	1000017240	CABLE-ASSY,PRESS PUMP 3 VG-640 TH
47	1000014515	CABLE-ASSY,PRESS PUMP 4 VG-640
47	1000017241	CABLE-ASSY,PRESS PUMP 4 VG-640 TH
48	1000014555	CABLE-ASSY,INK UNIT 0 VG-640
48	1000017242	CABLE-ASSY,INK UNIT 0 VG-640 TH
49	1000014563	CABLE-ASSY,RFID 1 VG-640
49	1000017243	CABLE-ASSY,RFID 1 VG-640 TH

Pos	Code	Description
50	1000014564	CABLE-ASSY,RFID 0 VG-640
50	1000017244	CABLE-ASSY,RFID 0 VG-640 TH
51	1000015782	CABLE,GST-250-R2M3
52	1000015569	CABLE-CARD,22P1 75L BB HIGH-V
53	1000014626	CABLE-CARD,40P1 3000L BB HIGH-V
54	1000015570	CABLE-CARD,15P1 2730L BB HIGH-V

